

Wood Fire Installation & Owner's Operation Manual

Tasman District Council
BUILDING CONSENT AUTHORITY

APPROVED BUILDING
CONSENT DOCUMENTATION

ALL WORK IS TO COMPLY WITH THE NZ BUILDING CODE
DO NOT MAKE CHANGES WITHOUT PRIOR APPROVAL

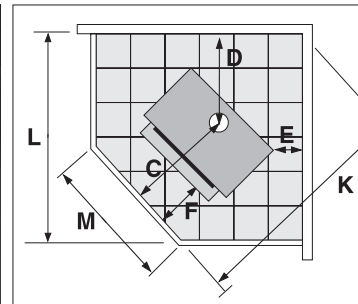
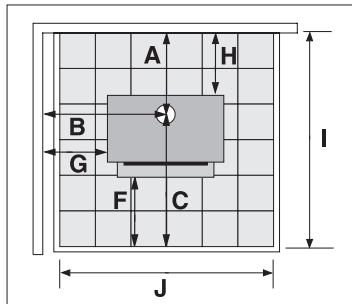

metrofires

Freestanding Wood Fires

Important information.....	2	Optional wetbacks.....	9
Assembling your Metro fire.....	2	Getting to know your Metro fire.....	10
Floor protector	4	Operating your Metro fire.....	10
Flue installation.....	5	Cleaning and maintenance	11
Wetback installation	6	Troubleshooting	12
Clearances and specifications	7	Metro Fires warranty	13
Important operation information	8	Replacement parts	14-15
Where to install a Metro fire in your home.....	9	Heating accessories.....	16



19 Oropuriri Road // New Plymouth 4312
info@metrofires.co.nz // www.metrofires.co.nz

WARNING! Important Information

- **WE HIGHLY RECOMMEND YOU READ THIS ENTIRE MANUAL AS INCORRECT OPERATION, MISUSE AND/OR LACK OF MAINTENANCE WILL VOID THE WARRANTY**
- The appliance and flue-system shall be installed in accordance with AS/NZS2918 and the appropriate requirements of the relevant building code or codes
- Any modification of the appliance that has not been approved in writing by the testing authority is considered to be in breach of the approval granted for compliance with AS/NZS4013 and will void the warranty
- The appliance must be installed correctly. We recommend a competent and suitably qualified NZHHA installer

CAUTION! Important Information

- Mixing of appliance or flue-system components from different sources or modifying the dimensional specification or components may result in hazardous conditions. Where such action is considered, the manufacturer should be consulted in the first instance
- Do not install a Metro fire if there is any sign of visible damage to the product
- This appliance must be regularly maintained.
- Use authorised Metro replacement parts only. The use of unauthorised parts may void the warranty
- This manual **MUST** be left with the home owner

All Metro wood fires comply with AS/NZS2918:2001 when installed in accordance with this manual. Please ensure you are fully conversant with the relevant standard and the contents of this manual. Correct installation is critical to the safe operation and performance of this wood fire.

Please take particular note of the following:

- It is recommended that Metro fires be installed with a Metro ECO flue system which has been developed to enhance the performance of Metro wood fires. Any alternative flue system must have a minimum flue pipe length of 4.2 metres of 150mm diameter flue pipe & have been tested to AS/NZS2918:2001
- The 150mm active flue pipe must be fully encased from the ceiling to the underside of the flashing cone at the top of the flue system, (i.e. there must not be any 150mm flue pipe exposed)

- All flue pipe joints must be sealed and riveted. The bottom of the flue pipe in particular **MUST** be fully sealed into the flue outlet of the Metro fire
- In New Zealand, the Metro fire must be bolted through the floor protector into the floor to comply with the seismic restraint provisions of AS/NZS2918:2001
- All Metro's are extremely heavy, varying in weight from 75kgs up to 185kgs. During the installation process do not lift the appliance by yourself, and take care not to damage the panel coating
- Please take care when lifting the Metro fire into place onto the hearth or floor protector as point loading may break tiles and/or scratch surfaces.

Assembling your Metro wood fire

Please note: You should only assemble this wood fire if you are suitably experienced in wood fire assembly and installation. The Metro carton shows the model Metro you are about to install, enabling you to select the appropriate model's assembly instructions.

All Metro wood fires are packed in a single heavy-duty carton, and tek screwed to a wooden pallet. Having removed the packaging and located this manual, familiarise yourself with the illustrations on pages 2 & 3, and proceed as follows.

Metro radiant fires

These Metro's are supplied virtually fully assembled. Packed inside the firebox you will find bricks in a cardboard wrapper, a wire door handle and the air control wire handle.

- Remove the two tek screws located at the base of each rear leg which secure the Metro to the wooden pallet, and carefully 'walk' the Metro off the pallet
- Open the door fully and fit the side bricks to each side of the firebox. Location lugs are fitted to the base and rear wall of the firebox to retain the side bricks in position. Refer to Diagram 2
- Attach the door handle to the door latch assembly by screwing it on clockwise
- Attach the air control wire handle by screwing it on clockwise.

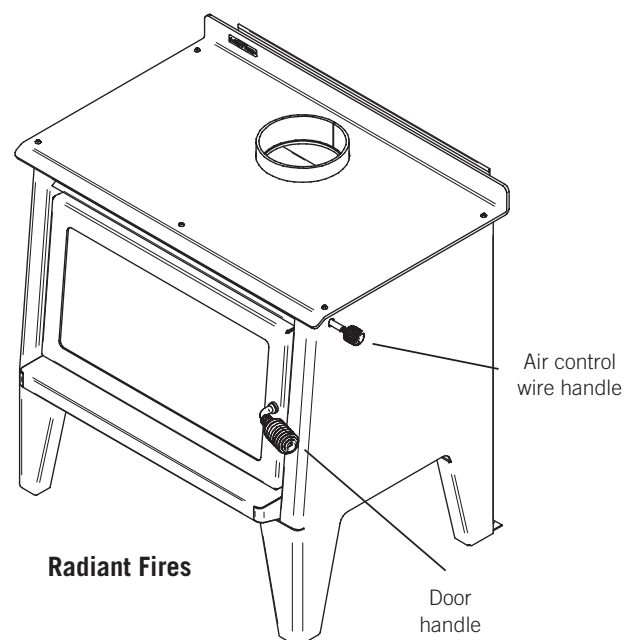

Assembling your Metro wood fire

Please note: You should only assemble this wood fire if you are suitably experienced in wood fire assembly and installation.

Metro pedestal and base model fires

To eliminate freight damage, the pedestal base has been packaged inside the firebox. To safely assemble your Metro, please proceed as follows:

- Lift off the top grill (convection models only) and place somewhere safe. Be careful not to chip the enamel coating or damage paint
- Open the door 45 degrees and lift the door off the hinge and place somewhere safe. Be careful not to damage the finish
- Remove the pedestal packed in a cardboard wrap
- Remove, rotate and re-fix the mount plate to the pedestal.

Note: The pedestal mount plate is fixed to the back of the pedestal base with 4x screws. This mounting plate must be removed, rotated and re-fixed to the pedestal as detailed on page 4 in diagrams 3 and 3A. The return fold must face back the opposite way to create the mount plate and fixing points for seismic restraint of the wood fire.

- Remove the pedestal heat shield

Note: For some models the pedestal heat shield may be taped to the rear heat shield. The ECO Tiny Ped's pedestal heat shield is pre-fitted.

- Remove the side bricks, door handle and the bolt bag
- Remove the 2 tek screws at the base of the inside of the firebox that fix the wood fire to the pallet.

It is recommended that 2 people work together with the next step:

- Grab the underneath top of the firebox door opening with one hand, holding the flue spigot with the other, slowly lift the front of the wood fire all the way back and rest the wood fire on its rear heat shield on the floor. Remove the packaging pallet.
- Fit the pedestal heat shield over the 4 bolts as shown in Diagram 1, with the open edge facing the front of the Metro (up)
- Position the pedestal with its front facing over the 4 bolts and fit the washers and nuts supplied, check to ensure the pedestal is correctly aligned and securely tighten the nuts.

It is recommended that 2 people work together with the next step:

- Grab the flue spigot with one hand and the other hand underneath the top of the firebox door opening, lift upwards standing the wood fire onto its pedestal
- Fit the side bricks to each side of the fire box. Location lugs are fitted to the base and rear wall of the firebox to retain the side bricks in position. Refer to Diagram 2. (Classic Rad also features two side rear bricks).
- Re-fit the door and top grill (Convection models only)

All Metro models

Check to ensure the top baffle is in its correct position in the top chamber of the firebox. It should be resting on four support lugs (two on each side of the firebox). The baffle must be hard back against the rear of the firebox with the "promet extension" (white board) or return front steel edge of the baffle facing forward as illustrated in Diagram 2.

Note: Some models feature a two-piece top baffle.

Diagram 1

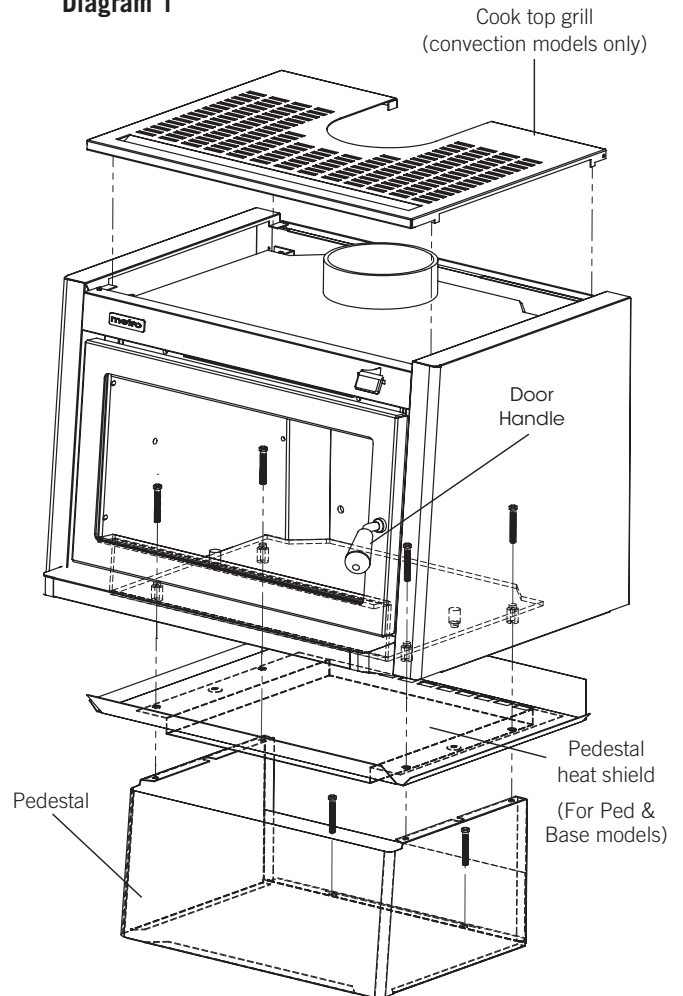
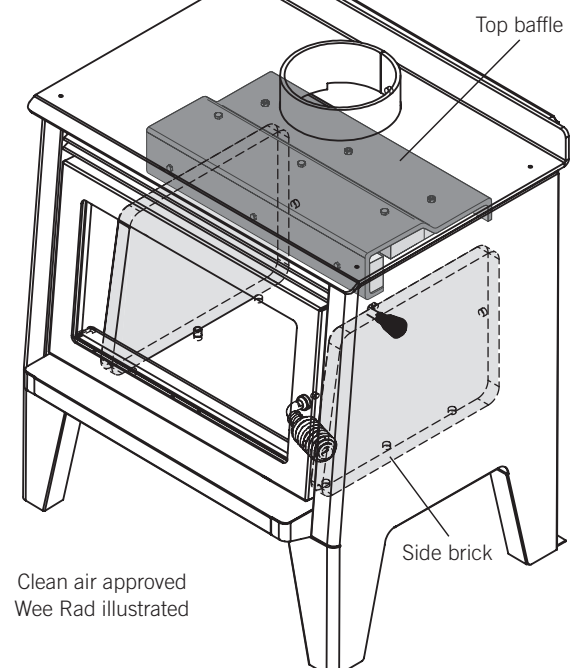

Diagram 2



Floor protector size, construction and fitting

Pioneer manufacture an extensive range of Pioneer 'Ash Floor Protectors' which comply with the minimum floor protector requirements of AS/NZS2918:2001, and can be installed with any freestanding Metro wood fire. Metro freestanding wood fires do not require an insulated floor protector as they comply with the minimum floor protector requirements of AS/NZS2918:2001. These minimum floor protector requirements are;

- They must be of adequate size to give appropriate wall, rear and front clearances/projections as detailed below and in the chart illustrated on page 7. Note;
- The floor protector must extend 200mm horizontally to the rear and each side directly below the door opening, and 300mm forward of the door opening
- The upper surface of the floor protector must be made of non-combustible material.

A suitable floor protector for a Metro freestanding wood fire is therefore any non-combustible material which could include;

- Ceramic tiles with grouted joints fixed directly to a hard base over timber flooring
- A sheet of toughened glass, panel steel etc. laid directly onto a wooden or other combustible floor.

Metro radiant fires

Lift the Metro fire onto the floor protector and using a suitable measuring device, ensure that the minimum wall clearances and front floor protector projections as detailed in the chart on page 7 are met or exceeded. Once the Metro's location on the floor protector is established and if the installation is within New Zealand, seismic restraint is required.

Using masonry anchors if the floor protector is on a concrete floor or coach bolts if a wooden floor, secure through the holes provided at the base, behind both rear legs.

Note: The anchors must pass through the floor protector and securely anchor the Metro to the floor.

Metro pedestal and base model fires

Prior to lifting the Metro fire onto the floor protector, ensure you have removed, rotated and re-assembled the mount plate from the back of the pedestal base as detailed in diagrams 3 & 3A above. This rear panel must be rotated with the return fold facing back the opposite way to create the mount plate and fixing points for seismic restraint of the wood fire.

Lift the Metro fire onto the floor protector and using a suitable measuring device, ensure that the minimum wall clearances and front floor protector projections as detailed in the chart on page 7 are met or exceeded.

Once the location of the fire is established, you can then secure the Metro through the floor protector into the floor using the two seismic restraint holes in the rear edge of the mount plate. Use masonry anchors if the floor protector is on a concrete floor or coach bolts if a wooden floor

Note: The anchors must pass through the floor protector and securely anchor the Metro to the floor.

Preparing the mount plate

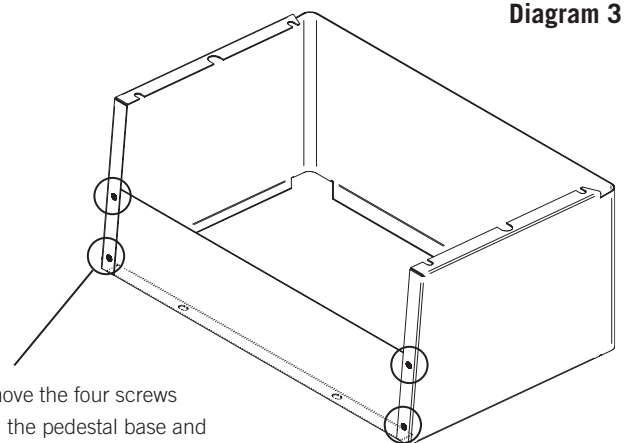

Diagram 3

Remove the four screws from the pedestal base and rotate the mount plate so the return fold faces back the other way. Refix in place.

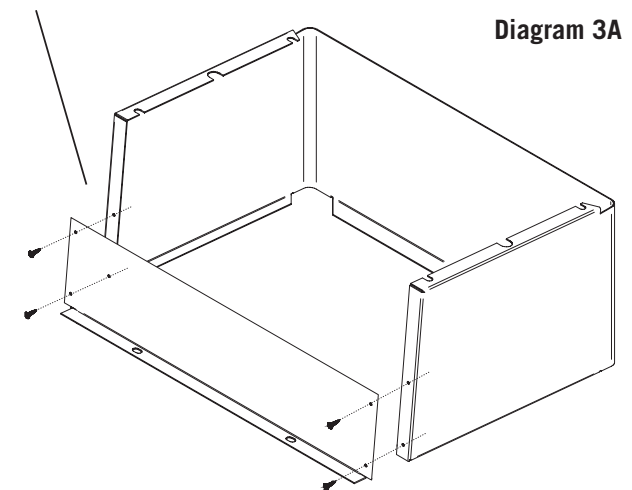
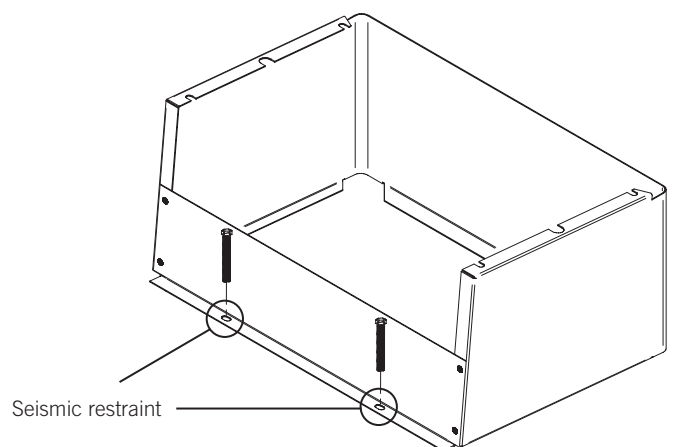

Diagram 3A

Correct mount plate position



Flue installation

It is recommended that all Metro freestanding wood fires be installed with the energy efficient ECO Flue System which comes complete with a detailed installation manual. This installation manual must be presented with your application to gain consent with your local council.

A copy of the ECO Flue System installation manual can be downloaded from metrofires.co.nz, or a copy can be obtained from your Metro retailer. Any alternative flue system must comply with and be installed as detailed in AS/NZS2918:2001, and a copy of the installation manual must also be presented with your application to gain consent with your local council.

All Metro fires require a 150mm diameter flue. Please note:

- Metro ECO flue systems must be installed to allow unrestricted air supply from either the ceiling cavity for an ECO Flue Kit, or above the roof line if the ECO Flue Kit and ECO Option Kits are both installed
- The ECO Flue system must be installed into a 'vented' flat ceiling cavity, or have an ECO Option Kit added to the flue system to provide an external air supply

- ECO Flue systems shall be installed in accordance with AS/NZS2918:2001 and the appropriate requirements of the relevant building codes
- Any modification to this flue system that has not been approved in writing by the testing authority is considered to be in breach of all approvals granted
- The flue systems 150mm diameter flue pipe must terminate a minimum of 4.6 metres above the top surface of the floor protector
- All joints in the flue pipe must be sealed with Pioneer fire cement (or similar) and riveted. The base of the flue pipe must also be sealed into the Metro fires flue outlet. This is critical for optimum operation.

All Metro fires have been tested with a Pioneer double flue shield. For the Metro fire to be installed with minimal clearances as the clearance table on page 7 states, only the Pioneer double flue shield can be used. All other flue shields will invalidate the installation.

Detailed below are the more common installation methods for installing Metro ECO Flue Systems. To ensure a safe and efficient installation, this flue system must be installed as detailed below by either a registered installer, or someone competent in installing solid fuel appliances.

Single Storey Installations

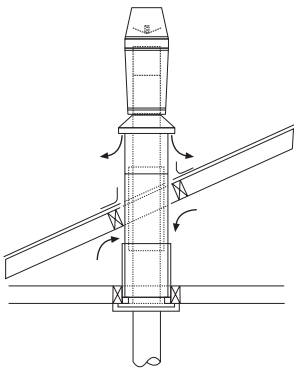

Flat Cavity Ceiling

ECO Flue Kit only required as air is drawn into the flue system direct from the ceiling cavity.

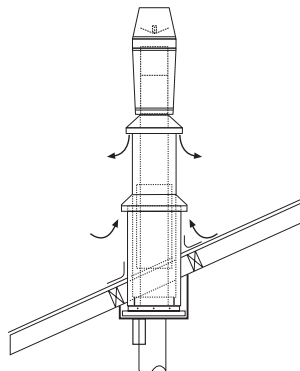

Sloping Ceiling

Both the ECO Flue Kit and ECO Option Kit are required to enable air to be drawn from outside the home.

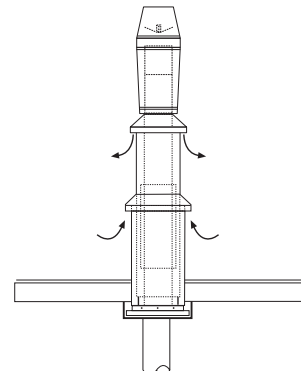

Flat Ceiling/Roof

Requires both ECO Flue Kit and ECO Option Kit as per sloping ceiling unless a vented ceiling cavity exists.

Two Storey Installations

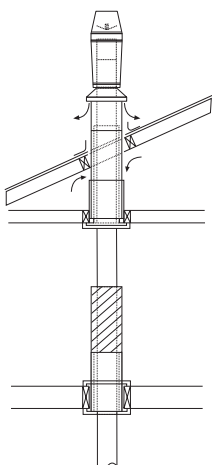

2nd Floor - Exposed Flue pipe

Requires an ECO Flue Kit only with additional lengths of flue pipe.

Additional components below are not supplied by Metrofires but are also required for this installation*

- A floor penetration kit
- 1x 1200mm long mesh/screen

*In accordance with AS/NZS2918:2001

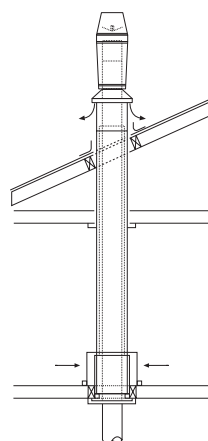

2nd Floor - Enclosed Flue pipe

Requires an ECO Flue Kit only with additional lengths of flue pipe.

Additional components below are not supplied by Metrofires but are also required for this installation*

- 200mm & 250mm inner/outer combination liners.
- 2nd floor vent cover and an additional ceiling plate with a 250mm diameter hole

*In accordance with AS/NZS2918:2001

Wetback installation

WARNING! Important Information

- **DO NOT** connect to an unvented hot water system
- Install in accordance with AS 3500.4.1 or NZS 4603 and the appropriate requirements of the relevant building code or codes.

CAUTION! Important Information

- Wetbacks must be connected with water before operating the fire and available to the wetback while the fire is in operation
- Wetback systems are not suitable for use in locations where the water supply has lime content. Lime build up inside the coil will eventually block the coil causing the wetback to fail
- Rainwater collection tanks installed lower than the wetback that use a water pump to supply the home, can cause problems if the pump is not operational. In these situations either the type of wetback or a roof header tank should be considered

Wetback	Suitable for models:
2kW Wetback 	<ul style="list-style-type: none"> • ECO Tiny Rad • ECO Tiny Ped
Side Wetback 	<ul style="list-style-type: none"> • Tiny Rad Woody • Wee Rad & Wee Rad Base • Wee Rad Woody • Wee Ped • Classic Rad
3kW Wetback 	<ul style="list-style-type: none"> • Xtreme Rad & Xtreme Rad Base • Xtreme Rad Woody • Xtreme Ped • Mega Rad • All LTD rural models
4kW Wetback 	<ul style="list-style-type: none"> • All LTD rural models

The R1 and R2 models cannot be fitted with a wetback.

Water heating is another key feature of your Metro wood fire; nearly all Metro models can be fitted with a wetback, which are designed to give maximum output with minimal effect on the operation of the fire. Only the Pioneer cast jacket wetback system should be fitted to your Metro; alternative wetbacks will void the Metro's emission approvals and may seriously affect the performance of the appliance and void its warranty.

Wetback connections are as follows, taken facing the Metro/wall; the return pipe connection is directly above the inlet connection. Heights for all models are illustrated and detailed opposite on page 7.

- ECO Tiny Ped and ECO Tiny Rad models are 92mm left of the flue centre
- The Tiny Rad Woody model is 184mm left of the flue centre
- Wee Series models are 226mm left of the flue centre
- The Classic Rad model is 184mm left of the flue centre
- All other models are 140mm left of the flue centre

All wetbacks are fitted to the inside rear wall of the firebox, with the exception of the Tiny Rad Woody, clean air Wee Series models and the Classic Rad model. Side wetback position for these models is to the outside left hand firebox wall. Please see the specific installation instructions in the 'Side Wetback' box for installation of a wetback into these appliances.

It is recommended the return pipe has a minimum rise of 1 in 12; performance will reduce as the distance to the storage cylinder increases.

To fit the wetback proceed as follows

1. Remove the rear panel of the Metro by removing the four pozi drive screws. Remove the two pre-punched knockouts from this panel.
 2. Two further knockouts will be visible on the inner rear heatshield, remove these also. Once these are removed 6mm nuts will be visible through the knockout holes.
 3. Open the Metro's door and locate two bolts securing the pressed washers which are visible on the left hand side of the firebox for both inlet and outlet connection points.
 4. A further three bolt heads will also be visible on the inside rear wall of the firebox; these are threaded into the 6mm thick firebox. Remove all three.
 5. Using the tube of sealant supplied with the wetback, apply a liberal bead of sealant around both the two connection pipes and also the outer circumference of the wetback which will face and press against the inside rear wall of the firebox. This will completely seal the wetback to the inside rear wall of the fire on installation.
- Ensure there is no gap between pipe and rear wall access holes. This cement must fully cure before appliance use.
6. Fit the wetback into the firebox and carefully pass the connection pipes through the holes in the rear of the firebox. Securely attach the wetback using the three bolts previously removed from the rear face of the firebox, fitting them through the slots provided in the wetback's jacket.
 7. The wetback is now ready for connection to the storage cylinder by a registered plumber.

Metro clearances and specifications

(Minimum clearances shown are in mm, with a Pioneer double flue shield fitted)

Minimum clearances

All Metro wood fires comply with AS/NZS2918:2001. Minimum clearances shown below are detailed in millimetres, with a Pioneer double flue shield fitted to the appliance. Measurements are taken from the following reference points as illustrated:

- From the nearest combustible wall or surface (A, B, D, E, G, H)
- From the Metro's flue centre (A, B, C, D)
- From the Metro's cabinet/heatshield outermost point (E, F, G, H)
- To the edge of the ash floor protectors non-combustible surface (C, F, I, J, K, L, M)

AS/NZS2918:2001 allows for a reduction in minimum clearances as detailed in Section 3, tables 3.1 and 3.2 of the standard.

Some Metro models have undergone additional testing which allows for reduced clearances. Please see the footnotes below the clearance table for the applicable models.

Wetback connections (taken facing the Metro/wall)

- ECO Tiny Ped and ECO Tiny Rad models are 92mm left of the flue centre
- The Tiny Rad Woody model is 184mm left of the flue centre
- Wee Series models are 226mm left of the flue centre
- The Classic Rad model is 184mm left of the flue centre
- All other models are 140mm left of the flue centre

Specifications were correct at the time of printing, but may alter and those detailed within should be used only as a guide. If in doubt, please consult your Metro retailer or metrofires.co.nz.

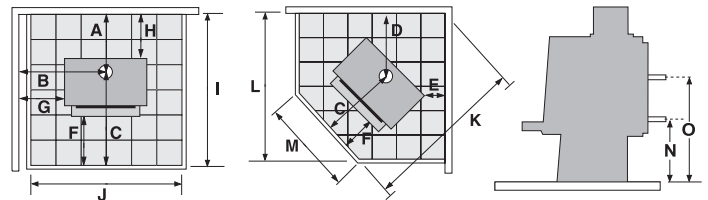

Clean air models	Minimum installation clearances with a Pioneer double flueshield fitted (mm)													Wetback		Dimensions		
	A	B	C	D	E	F	G	H	I	J	K	L	M	N	O	Width	Depth	Height
ECO Tiny Ped	210	430	580	290	25	200	185	60	790	650	990	875	250	280	470	490	530	665
ECO Tiny Rad	225	552	580	420	150	200	300	75	805	650	1165	925	250	280	470	505	530	665
Tiny Rad Woody	251	568	580	382	110	230	310	100	831	650	1120	880	250	365	555	515	498	758
R1	243	774	586	554	280	244	530	100	829	825	1370	1118	425	N/A	N/A	488	485	668
R2	246	858	626	582	275	235	570	100	872	905	1449	1203	505	N/A	N/A	575	537	690
Wee Rad ¹	251	568	580	455	150	230	260	100	831	825	1224	1015	425	295	485	615	501	688
Wee Rad Base	271	678	580	489	180	230	370	120	851	825	1270	1049	425	295	485	615	501	691
Wee Rad Woody	271	708	580	509	200	230	400	120	851	825	1285	1069	425	365	555	615	501	758
Wee Ped ²	263	651	580	490	170	230	350	110	843	825	1274	1050	425	295	485	602	503	665
Classic Rad ³	257	695	780	500	220	229	430	100	1037	728	1487	1168	328	393	583	530	707	680
Xtreme Ped	251	624	630	441	110	227	280	100	881	907	1254	1065	507	312	502	688	554	721
Xtreme Rad	251	650	630	458	100	227	280	100	881	907	1277	1077	507	312	502	740	554	743
Xtreme Rad Base	251	650	630	458	100	227	280	100	881	907	1277	1077	507	312	502	740	554	743
Xtreme Rad Woody	251	680	630	478	120	227	310	100	881	907	1292	1097	507	382	572	740	554	813
Mega Rad	285	720	728	497	100	224	300	130	1013	1006	1431	1227	606	300	490	840	659	744
LTD rural models	A	B	C	D	E	F	G	H	I	J	K	L	M	N	O	Width	Depth	Height
LTD Wee Rad	251	548	580	425	120	230	240	100	831	825	1180	985	425	295	485	615	501	688
LTD Wee Rad Base	251	658	580	489	180	230	350	100	831	825	1270	1049	425	300	490	615	501	691
LTD Wee Rad Woody	271	708	580	509	200	230	400	120	851	825	1285	1069	425	360	550	615	501	758
LTD Xtreme Rad	251	650	630	458	100	227	280	100	881	907	1277	1081	507	350	540	740	554	743
LTD Xtreme Rad Base	251	650	630	458	100	227	280	100	881	907	1277	1081	507	350	540	740	554	743
LTD Xtreme Rad Woody	251	680	630	478	120	227	310	100	881	907	1292	1097	507	420	610	740	554	813
LTD Mega Rad	285	720	728	497	100	224	300	130	1013	1006	1431	1227	606	300	490	840	659	744

The Wee Rad installed with a Pioneer double flue shield with the Wee Rad corner wing shields fitted allows for reduced clearances as follows:

¹ Wee Rad corner clearance (E) can be reduced to 120mm. This in turn also reduces clearances (D) to 425mm, (K) to 1180mm and (L) to 985mm. When fitting the corner wing shields, the Wee Rad itself must be installed to a corner clearance (E) of 120mm. The corner wing shields are then fitted which gives a wall to shield corner clearance of 100mm.

The following models installed with a Pioneer double flue shield with the side extensions fitted allows for reduced clearances as follows:

² Wee Ped corner clearance (E) can be reduced to 115mm. This in turn also reduces clearances (D) to 436mm, (K) to 1197mm and (L) to 996mm.

³ Classic Rad corner clearance (E) can be reduced to 180mm. This in turn also reduces clearances (D) to 460mm, (K) to 1430mm and (L) to 1127mm.

WARNING! Important Information

- **WE HIGHLY RECOMMEND YOU READ THIS ENTIRE MANUAL AS INCORRECT OPERATION, MISUSE AND/OR LACK OF MAINTENANCE WILL VOID THE WARRANTY**
- Any modification of the appliance that has not been approved in writing by the testing authority is considered as breaching AS/NZS 4013 and will void the warranty
- Do not use flammable liquids or aerosols in the vicinity of this appliance when it is operating
- Never operate your Metro with the top grill removed
- Do not dry clothes on or near this appliance
- Do not use flammable liquids or aerosols to start or rekindle the fire OR store fuel within the Metro's specified installation clearances
- Never operate your Metro with the door ajar, except on initial start up
- Open the air control fully before opening the Metro's door.

CAUTION! Important Information

- This appliance should be maintained & operated at all times in accordance with this instruction manual
- This appliance should not be operated with cracked door glass, over worn, faulty or missing door seals
- Do not use driftwood, treated or unseasoned (wet) fuel, the use of most types of preservative treated wood as fuel can be hazardous and will damage your appliance
- Burning unseasoned (wet) fuel or incorrect operation on extended low burn cycles will cause excessive creosote to form. Creosote is very corrosive and excessive buildups will result in the flue pipe, flue spigot and upper burn chamber failing. Failure of the appliance and/or flue system due to creosote damage is not covered under warranty. The formation of such is not an appliance issue it is a fuel and operational issue
- This appliance must be regularly maintained and replacement parts must be authorised Metro parts only
- Do not empty ash into a combustible container.

Congratulations on the purchase of your Metro wood fire

This slow combustion appliance is designed to give you many years of warmth and service, subject to the following key factors. These key factors, if not adhered to are the major causes of unsafe installation, poor performance and flue blockages and potential product failure.

1. Your Metro wood fire must be installed correctly. Metro recommend a competent and suitably qualified NZHHA installer.
2. The only fuel to be used in this appliance shall be wood that meets the following criteria.
 - Less than 25% moisture content
 - Has not been treated with preservatives or impregnated with chemicals or glue,
 - Is not chipboard, particle board, or laminated board,
 - Is not painted, stained or oiled
 - Is not driftwood or other salt impregnated wood
3. The appliance shall be operated at all times in accordance with the "Installation and Operating Instructions" supplied with each appliance.
4. It is preferable that Metro wood fires should be installed with a Metro ECO Flue System.
5. Coal must not be used as a fuel.

Please also note the following important points:

- In New Zealand a building consent is required from your local building authority. The homeowner is responsible for obtaining this consent
- As correct installation is critical to the performance and safe operation of your Metro, it is recommended your Metro be installed by a NZHHA registered installer or a person suitably qualified in the installation of wood fires. Your Metro retailer will be able to arrange professional installation for you
- During the very first fire your Metro will give off an odour and fumes as the firebox paint cures. Do not be alarmed; open all windows and externally opening doors in that room and close any internally opening doors. This curing process will last for approximately one hour and is likely to happen this one time

- Properly seasoned (dry) timber is necessary for the Metro to operate efficiently; firewood that contains a high moisture content will result in flue pipe blockages, reduce heat output and create other issues.

Note: Once split, Softwood usually takes 12 months to season - Hardwood can take up to 24 months to season - Wood must be stored in a location that enables air circulation. Unseasoned wood stored in a closed woodshed without air circulation will still be unseasoned 12 months later.

- It is critical that the fire not be operated with over worn, faulty or missing door seals. Door seals will harden over time and become over-worn (3-4 year's) this will cause air to leak into the fire, causing the appliance to 'over fire'
- It is critical that the fire not be operated with over worn, faulty or missing bricks, baffle plate, promet extension (white board on the baffle plate)
- It is critical that the fire not be operated with cracked or broken door glass.

Please note, the above 3 points require regular inspection/maintenance (every time the ash bed is cleaned out, generally 3-5 times a season) and if not maintained will void the firebox warranty. A glowing firebox or lower fluepipe is just one sign you are over firing your appliance. Please ensure you keep your proof of purchase/receipt on any parts you purchase.

- For optimum performance fuel must be loaded so the logs lay "front to rear" in preference to laying across the width of the firebox. Spaces should be left between the logs to enable oxygen to get to as much of the surface of the fuel as possible
- A small hot fire loaded frequently is more efficient than a large fire burning on a low setting
- Your Metro is covered by a full unconditional 12 month warranty on replacement parts, and a 10 year firebox warranty.

Where to install a Metro wood fire in your home

Wood fires are usually installed in the main living area, which is the section of the home that is usually kept the warmest, being the area in the home most frequently occupied. However, before deciding on the best location for your Metro wood fire you may wish to consider:

- Water heating. If you are intending to have a wetback it is important that the wood fire is as close as practically possible to the water storage cylinder
- Split level homes are best heated when the wood fire is installed on the lower level, as the heated air will rise to the higher levels
- Building construction is another consideration. Specified clearances from walls, curtains etc must be maintained and you need to ensure no structural beams or internal gutters etc are directly above your preferred site. If you have a two storey dwelling you need to consider the second storey to ensure you don't have the flue directly outside a second storey window.

Generally, you can install your Metro in your home anywhere that suits you; Pioneer offer various fan systems to transfer heat to other sections of the home that are not heated sufficiently. It is necessary if using a fan system that the Metro you have purchased has sufficient output to heat the total area you wish to heat. Your Metro retailer or installer will be able to advise if you are uncertain.

Optional wetbacks

Water heating is another key feature of your Metro wood fire; nearly all Metro models can be fitted with a wetback, which are designed to give maximum output with minimal effect on the operation of the fire. Only the Pioneer cast jacket wetback system should be fitted to your Metro; alternative wetbacks will void the Metro's emission approvals and may seriously affect the performance of the appliance and void its warranty.

Other considerations are:

- Distance from your Metro to the storage cylinder will affect the amount of hot water produced
- Your climate & the manner in which you will 'fire' your Metro will determine the amount of hot water produced.

Note: Wetbacks are not suitable for use in locations where the water supply has lime content. Lime build up inside the coil will eventually block the coil causing the wetback to fail.

Cost Savings

Wetbacks can enable substantial power savings, dependent on the climate in the area in which you live. If you live in a cold climate you are likely to use your Metro for many months of the year, in which case a Pioneer wetback will reduce or even eliminate your water heating costs over those months. If however you live in a warmer climate and use your Metro for only a few hours a day over the colder months, electricity savings will be considerably less.

Water Pressure

A common misconception is that you must have a low-pressure system to have a wetback; this is not true. You must have a 'vented' system and high-pressure cylinders are usually not vented. However you can install an 'indirect' cylinder which contains a secondary coil inside the storage cylinder, enabling you to have a wetback while retaining a high-pressure system.

Wetback	Suitable for models:
2kW Wetback 	<ul style="list-style-type: none"> • ECO Tiny Rad • ECO Tiny Ped
Side Wetback 	<ul style="list-style-type: none"> • Tiny Rad Woody • Wee Rad & Wee Rad Base • Wee Rad Woody • Wee Ped • Classic Rad
3kW Wetback 	<ul style="list-style-type: none"> • Xtreme Rad & Xtreme Rad Base • Xtreme Rad Woody • Xtreme Ped • Mega Rad • All LTD rural models
4kW Wetback 	<ul style="list-style-type: none"> • All LTD rural models

The R1 and R2 models cannot be fitted with a wetback.

Getting to know your Metro wood fire

Operating your Metro fire is simple and you will quickly learn how to get the best from it. First take a minute to familiarise yourself with your new Metro.

- Raise the door handle anti-clockwise until the latch releases, and then slowly pull the door open. You will note that if you let the door go before it is at 90° to the appliance, it will fall closed. This is a safety feature that ensures the door cannot fall open if it is not latched securely. For the door to remain open, you must open it fully
- There is a single air control making your Metro fire easy to adjust. This control moves from left to right, which is 'low to high'.

All Metro radiant fires have a wire air control handle located at the upper right hand side of the appliance. Simply pull out to increase burn rate or push in to reduce burn rate.

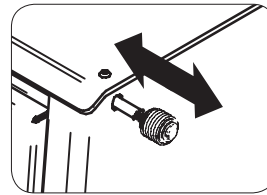

Radiant fires air control

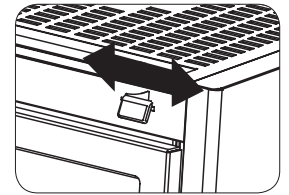

All other fires air control

All other Metro fires have an air control knob located on the upper front panel of the appliance.

Slide this control knob gently from right to left until you reach a stop. This is a pre-set 'low' position. Your Metro fire must not be operated at a lower burn rate than this pre-set low allows.

Operating your Metro wood fire

If your Metro has only been installed within the past few days, the fire cement seal at the base of the flue will not be fully cured. To ensure the cement sets without blistering it is recommended you burn 2-3 sheets of loosely crumpled newspaper at a time, approximately once every hour over a 6-8 hour period.

During the very first fire your Metro will give off an odour and fumes as the firebox paint cures. Do not be alarmed. Open all windows and externally opening doors in that room and close any internally opening doors. This curing process will last for approximately one hour and is likely to happen this one time.

Start up

Place a quantity of loosely crumpled newspaper on the base of the firebox until it is approximately half full of paper, or place firelighters on the base of the firebox. Add dry kindling and move the air control knob fully to the right, being the 'full open' position.

Light the paper at two or three locations across the front of the door opening and leave the door slightly ajar resting on the latch pin if necessary for a few minutes while the fire establishes. Once the kindling is burning well, open the door and add 2-3 small logs at a time until you have a well-established fire. Usually this will take approximately 30 minutes, during which time the air control should be set on "high" and the door should be closed, except for the initial few minutes and when fuel is being added.

Normal operation

Once the fire is well established, regulate the air control to achieve the desired burn rate and heat output. As you move the air control to the right, burn rate, firebox temperature and heat output will increase, if you move the control to the left they will decrease. Please note:

- Always open the air control fully prior to opening the door, then open the door slowly. Every time you refuel, leave the air control on 'high' for a minimum of 20-25 minutes
- When loading logs, place them end-on, 'front to back'; air spaces should be left between the logs to enable oxygen to get to as much of the surface of the fuel as possible
- Never use the door to force wood into the firebox, as this is likely to break the glass.

Extended burning (rural models only)

It is most important if your Metro is to be refuelled and turned down for an extended period, such as an overnight burn that you operate it correctly:

- The wood used as fuel for extended burning **MUST BE FULLY SEASONED (DRY)**. Once the fuel is loaded, the appliance must be operated on high for a period of at least 20 minutes to drive out residual moisture from the fuel (dry wood is usually 20% water content) and ensure surface area combustion.
- Do not turn the air control down lower than you need to, if you want the Metro to burn overnight, endeavour to obtain an 8 hour burn time, not 12 hours. It will take a few burns to find the correct location of your Metro's air control setting to achieve the length of burn cycle you desire as this setting is affected by several variables including fuel density, flue length and outside wind velocity.
- A smouldering fire over a long time frame is likely to deposit corrosive elements into your system which could be detrimental to your Metro.

⚠ CAUTION! Important Information

- If not operated correctly on extended burn cycles, your Metro is likely to incur flue blockages, corrosion of the upper baffle, lower flue pipe and firebox flue spigot. As these are not covered under warranty if they fail through improper use, it is important you operate your Metro correctly.

Cooking

All Metro's are designed to enable cooking of soups, stews and casseroles etc, and your Metro will easily boil a flat bottom stainless steel kettle. The Radiant Series have a dedicated cooking top enabling large pots to be placed on the cook top, while all other models have a lift-off grill.

Note: Metro's supplied with a lift-off top grill have this feature to enable the grill to be removed for cleaning if you have a spill. The lift-off top grill must be left on when cooking, because if removed the wall temperatures next to the appliance may become excessive and the top of the firebox is generally too hot to cook on directly.

Cleaning and maintenance for your Metro wood fire

Your Metro fire will give you many years of efficient service with minimal maintenance if operated correctly using seasoned fuel. Your Metro fire must be regularly maintained and replacement parts must be authorised Metro fires parts only.

The Metro radiant fires are painted wood fires and coated with 'Pioneer Metallic Black' high temperature paint and will require periodic repainting to keep them looking their best.

All other Metro fires are coated with vitreous enamel. Vitreous enamel is extremely durable and designed to last the life of the appliance. As vitreous enamel is glass, a solid or heavy object dropped or banged against a panel could chip the enamel surface.

All model Metro fires can be cleaned with a soft cloth when the appliance is not in operation.

Door glass

Providing your fuel is properly seasoned, under normal operating conditions the air-wash design of the Metro's firebox will keep the door glass clear. If the glass requires cleaning you may use either a razor blade scraper or crumpled wetted newspaper dipped in wood ash rubbed over the glass.

If your door glass breaks it must be replaced with 5mm thick ceramic glass which is available from your local Metro retailer.

Door seals

Over time, usually 3-4 years, the door and glass seals will become hard and cause air to leak into the firebox, causing the appliance to 'over fire'. Your Metro retailer stocks replacement woven fibreglass door and glass seals, which need replacing when they become hard and over worn.

The door of your Metro is easily removed. Hold it in both hands and lift the hinge end of the door up and over the top hinge pin, then lower the door from the bottom hinge pin.

Side bricks

Hair-line cracks are not uncommon and are a result of the intense heat within the Metro's firebox, coupled with mechanical damage caused by accidental impact when fuel is being loaded. However if the side bricks become cracked to the extent that they start to break up, they must be replaced.

Door adjustment

Provision is available on both sides of the door for adjustment.

To adjust the hinge end of the door, open the door fully, loosen the top hinge nut and slightly lift the latch end of the door; you will see the hinge assembly move back 1-2mm which will usually be sufficient. Retighten, then repeat by loosening the lower hinge nut, this time applying a slight downwards pressure onto the door to move the lower hinge assembly back a similar distance, then retighten.

The door latch is also adjustable, as the latch pin on the right side of the firebox is fitted through a slot which enables the latch pin to be loosened, moved back and re-tightened.

Ash removal

Over a period of time ash will build up in the base of the Metro's firebox and require removal. The time this build-up takes depends on the density and cleanliness of your fuel.

To remove the excess ash your Metro should not be operating.

- Open the door, and using a hearth shovel or similar, empty the excess ash directly into a steel or non-combustible container.
- If the ash is not disposed of immediately, be careful where you store it, as the ash can retain heat for many days and become a fire hazard.
- You must leave a bed of ash in the base of the firebox approximately 10mm deep; this insulates the base of the firebox and improves combustion.

Top baffle

This is a 'sacrificial' wear part of the firebox and should be checked monthly. Usually only the promet (white board) front/underneath section needs to be replaced when it starts to disintegrate.

Note: Cracks in the promet are not uncommon and have no adverse effect on the operation of your Metro. These cracks are the result of intense heat coupled with expansion and contraction. Burning wood which is not properly seasoned, i.e. 25% moisture content or more, will over time cause the promet to disintegrate and require replacement.

Flue systems

Should be checked annually, particularly the bottom end of the lower flue section at its rear lock formed joint. If deterioration is noticed contact your Metro retailer or installer.

The flue pipe should also be swept a minimum of once a year, or as required during the winter season. If smoke enters the room when you open the Metro's door this usually indicates the flue pipe is becoming restricted and needs cleaning. The frequency of flue pipe cleans depends on many factors, with the main variables being:

- The seasoning of the wood. If not properly seasoned you will require frequent flue pipe cleans.
- The density of the wood. Softwoods generally result in more deposits building up in the flue pipe.

To clean the flue pipe of your Metro, proceed as follows:-

- Open the Metro's door fully, reach inside with the palm of your hand face-up and extended, lift the top baffle approximately 20mm, then lift it forward out through the door opening, placing it on a sheet of newspaper you have placed on the front of the floor protector. To prevent jamming, removal and replacement of the top baffle is best performed using both hands.

Note: Some appliances have a two piece top baffle.

- Close the door and slide the air control to the left.
- Once on the roof, remove the cowl from the top of flue system and sweep the flue pipe using a 150mm-diameter flue pipe brush as detailed in the instructions provided with the fluebrush.
- Once the flue pipe is clear, clean and refit the cowl. Remove the excess soot which has fallen into the firebox, leaving a layer of ash 10mm deep on the base of the firebox, then refit the top baffle.

Note: The baffle must be fitted so its rear is touching the back of the firebox; if uncertain refer to page 3 in the installation section at the front of this manual, which shows illustrations of the baffle location.

Troubleshooting your Metro wood fire

If your Metro is installed correctly, your fuel is dry and you operate your fire correctly, you will find it to be a pleasure to use. Metro's many years of experience within the wood heating industry has shown that dissatisfaction is mainly due to:

- unseasoned fuel
- faulty installation
- operational error
- or a combination of the above 3 points.

Correct operation

Modern day wood fires need to be operated hard and fast, more so than low and lazy to ensure the firebox and flue pipe runs hot and efficiently. If the fire and flue pipe is up to temperature it will perform extremely well, the smoke will draw up the flue pipe with ease, and the fire will produce good amounts of heat.

If the fire is operated on low a lot of the time, the door glass will run black, the flue pipe will tend to block up more frequently and the fire will end up smoking into the room when reloading. It's better to have a small fire running hard and fast, rather than a big fire running low and lazy.

The following may be of assistance if you are experiencing any problems with the operation of your Metro Fire.

Smoke enters the room when the Metro's door is ajar

(possible reasons and solutions)

Check flue pipe joins

If the flue pipe joins are not sealed correctly, the flue pipe will not draw as well as it should. The flue pipe join connecting into the flue spigot on top of the Metro is most critical, if this is not sealed correctly, smoke will enter the room when the door is ajar. To check this join is sealed correctly, run a match or lighter flame around the join. If the flame is sucked into the spigot then it is not sealed correctly. This check needs to be done when the fire is not going. Ensure you check the rear of the flue pipe/spigot join, as due to the seam in the flue pipe, this is the most common area for not being sealed correctly.

Ensure the fuel you are using is correctly seasoned

If you are burning unseasoned fuel (wet), the fire will cause nothing but problems. The Metro won't deliver much heat, it will be lazy, smoke will enter the room when the door is ajar, and the door glass will run black. Unseasoned fuel is the main contributor to excessive creosote deposits which can be corrosive to your appliance and flue system.

Flue pipe length is too short

Add more flue pipe as the longer the flue system, the better the draw of the flue pipe. Please note, if you did not purchase the Metro ECO Flue System, you will not have the ECO Cowl which increases draw. We highly recommend the Metro ECO Cowl is fitted as this will increase the draw. If you already have an ECO Cowl and smoke is still entering the room, please add another 600mm length of flue pipe.

Downdraft/Turbulence blockage

If you have checked all of the previous factors and the fire is still smoking into the room, it's possible there may be a down draft issue. Down draft is environmental and can be caused by many variables, and it is purely trial and error to ascertain the cause.

Air turbulence and/or negative air pressure influences around the flue termination can be caused by too close or overhanging trees or natural/artificial ridges etc. Address these where possible or look to extend the flue above the roofline.

Other options may be:

- 'H' Cowl, designed purely for downdraft issues, but if you have an ECO Cowl fitted as standard, you will also need to add another 600mm of flue pipe to compensate as the H Cowl is shorter in length
- Directional Cowl, designed for high wind areas.

Air control setting

Ensure the air control setting is on high before opening the door to reload, as this increases the draw up the flue pipe. Open the door slowly.

If your Metro did not smoke, but its starting too and is getting worse:

The flue pipe is in need of a clean. It is recommended that the flue pipe be cleaned every season, however if you are burning the fire on low a lot, or are using unseasoned fuel, flue pipe cleans will be required more frequently.

Other issues you may experience

I can smell smoke in the room after a low burn cycle

The smell is creosote that will be seeping through the flue pipe join or out of the flue spigot onto an external surface, thus creating the smell in your room. The cause will be either unseasoned fuel, fuel mass too large, incorrect operation on low burn cycles or a combination. Creosote is very corrosive and excessive buildups will result in the flue pipe and potentially the flue spigot and upper burn chamber failing. The formation of excessive creosote is not an appliance issue, it is a fuel and operational issue. Failure of flue pipe or firebox due to creosote build up is not covered under warranty as excessive creosote build up is only possible from either unseasoned fuel or incorrect operation.

The Metro is noisy as it heats up and cools down

There will always be some expansion and contraction noise as the Metro heats and cools. This can usually be reduced by loosening three nuts at the rear of the appliance. To remedy, locate the 25mm deep cavity at the rear of your Metro between the 'rear panel' and the 'inner rear heat shield'. You will see a 6mm nut and two 6mm bolt heads in this cavity. Using a 10mm ring or open ended spanner, loosen all three so they are finger tight only.

On all Metro freestanding fires the air channel that allows the combustion air to enter the fire is fitted to the top underneath of the door opening. It is fitted with two M6 bolts. Slightly loosen both of these bolts.

The Metro won't turn down as much as it did

The door itself may need readjusting, the hinge and latch is slotted and allows for movement. Loosening the hinge and moving it back a few mm will make the door seal tighter and stop air leaking into the fire. The door and glass seals may be in need of replacing, which is generally required every 3-4 years.

Familiarise yourself with the instructions on page 10 before proceeding with this maintenance.

Warranty details for your Metro wood fire

Metro wood fires are manufactured in New Zealand, using the highest quality of materials, workmanship and the latest manufacturing techniques, which is why we offer a full 10 year firebox warranty and a 1 year parts warranty for your peace of mind.

Metro Warranty

(NZ Consumer laws apply to this warranty)

Pioneer Manufacturing Limited (Pioneer) warrants the steel firebox against defective materials and workmanship which would render it unfit for normal domestic use, from the date of purchase by the original consumer, for a period of 10 years.

Components including panel coating, door retainers, door seals, glass, trim, baffle & bricks are warranted for a period of 1 year from the date of original purchase for normal domestic use against defective materials and workmanship.

All associated accessories including, but not limited to, fans, flue systems, flue shields, wetbacks, tool sets, ash pots etc, are covered by a 1 year warranty against defective materials and workmanship.

It is recommended, but not a condition of this warranty, that a full service/inspection of the Metro fire be carried out at the end of each winter season.

Warranty Conditions

- The Metro fire must be installed, operated and maintained strictly in accordance with the building code and this installation and operation manual
- The Metro fire must be installed and used in a domestic application
- This warranty covers appliance like for like replacement or repair at the manufacturer's discretion but excludes freight, travel, installation, labour and/or any other associated costs
- Pioneer or their agents are not liable for any loss or expense direct or indirect arising from the failure of any part or operation of the appliance
- Operation of this appliance in violation of the warnings in this operation and installation manual will void this warranty
- Your Metro fire must be regularly maintained and we recommended it is also serviced annually. Proof of servicing may be required. If a wood fire is not regularly maintained and serviced, the life span will be reduced. If your Metro wood fire has been neglected, by not being regularly maintained and serviced, warranty may be declined

CAUTION! Important Information

Note: The following 3 points require regular inspection/maintenance (every time the ash bed is cleaned out, generally 3-5 times a season) and if not maintained will void the firebox warranty. Please ensure you keep your proof of purchase/receipt on any parts you buy.

- It is critical the fire not be operated with over worn, faulty or missing door seals. Door seals will harden over time and become over-worn (3-4 year's) and will cause air to leak into the fire, causing the appliance to 'over fire'. Do not operate the fire with cracked, or broken door glass
- It is critical the fire not be operated with over worn, faulty or missing bricks, baffle plate or baffle extension (white board on or under the baffle plate)
- A claim under this warranty should be directed to the retailer who supplied the Metro fire. If this is not possible write directly to the manufacturer stating details of fault, model, serial number of your Metro, dated proof of purchase and name of retailer purchased from.

Warranty Exclusions

(This manufacturer's warranty does not cover)

- Service calls which are not related to any defect in the product (i.e. operational, installation or fuel issues). The cost of a service call will be charged if the problem is not found to be a product fault
- Defects caused by factors other than normal domestic use or use in accordance with the product's operation manual
- Defects caused through the product being operated in an 'over-fired' manner resulting in sections of the firebox operating excessively hot to the point that sections glow red. (Note – This will result in distortion of the firebox)
- Defects to the product caused by accident, neglect, misuse or act of God
- The cost of repairs carried out by non-authorized repairers or the cost of correcting such unauthorised repairs
- Required maintenance as set out in this manual.

Service under this manufacturer's warranty must be provided by a repairer authorised by Pioneer Manufacturing Ltd. Such service shall be provided during normal business hours.

IMPORTANT! Complete and retain these details at time of purchase:

Purchase Date

Serial Number

Model

Colour

Retailer









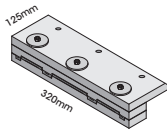
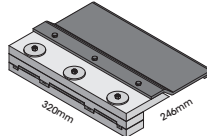

Parts guide for your Metro – Promet, baffles and wetback options

Your Metro wood fire must be regularly maintained and we recommended it is also serviced annually. If a wood fire is not regularly maintained and serviced, the life span will be reduced.

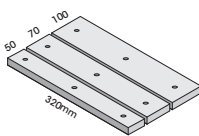
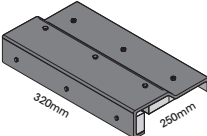
If your Metro wood fire has been neglected, by not being regularly maintained and serviced, with authorised Metro parts replaced as required, your warranty may be declined.

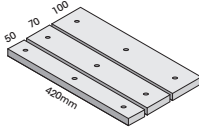
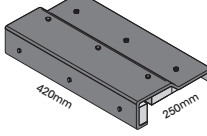
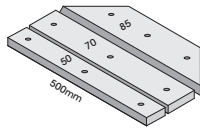
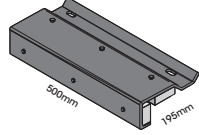
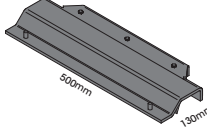
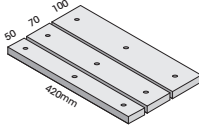
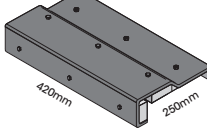
Listed below are the parts and product codes for your Metro wood fire. The promet/baffle should be regularly checked and must always be in place during the operation of your fire.

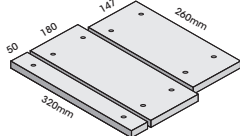
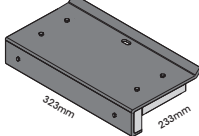
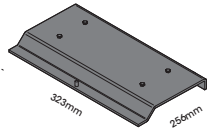
The baffle should be resting on four support lugs (two on each side of the firebox). It must be hard back against the rear of the firebox with the 'promet extension' (white board) or return front steel edge of the baffle facing forward.









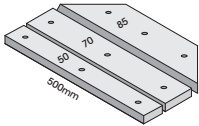
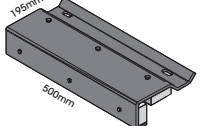
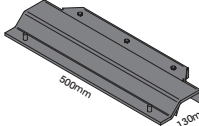

Model	Type of promet required / Type of steel baffle(s) required			Wetback options
<ul style="list-style-type: none"> • ECO Tiny Ped • ECO Tiny Rad 	ECO Tiny Promet 500-1550 	ECO Tiny Baffle 500-2050 	ECO 2kW Booster 450-0050 	
<ul style="list-style-type: none"> • Tiny Rad Woody 	Tiny Woody Promet Set 500-2004 	Tiny Woody Baffle 500-2504 	Side Wetback 450-0275 	
<ul style="list-style-type: none"> • R1 	Wee/R1 Promet Set 500-2005 	Wee/R1 Baffle 500-2505 	No wetback can be fitted to this appliance	
<ul style="list-style-type: none"> • R2 	Xtreme/R2 Promet Set 500-2010 	Xtreme/R2 Front Baffle 500-2510 	Xtreme/R2 Rear Baffle 500-2515 	No wetback can be fitted to this appliance
<ul style="list-style-type: none"> • Wee Rad • Wee Rad Base • Wee Rad Woody • Wee Ped 	Wee/R1 Promet Set 500-2005 	Wee/R1 Baffle 500-2505 	Side Wetback 450-0275 	
<ul style="list-style-type: none"> • Classic Rad 	Classic Rad Promet Set 500-2015 	Classic Rad Front Baffle 500-2520 	Classic Rad Rear Baffle 500-2525 	Side Wetback 450-0275 

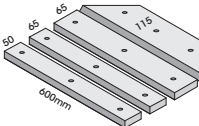
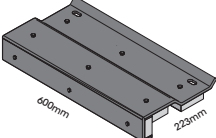
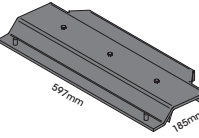
Parts guide for your Metro – Promet, baffles and wetback options

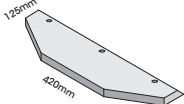
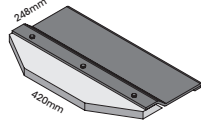
Hairline cracks in the promet extension are not uncommon and will have no adverse effect on the operation and performance of your Metro wood fire. These cracks are the result of intense heat coupled with expansion and contraction and is normal wear and tear.

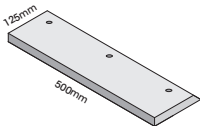
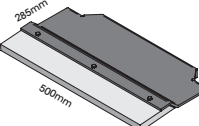
Note: Impact damage when loading wood and burning wood which is not properly seasoned, i.e. 25% moisture content or more, will cause the promet to disintegrate and require replacement. Always burn dry well seasoned wood and take care when loading wood into the firebox.

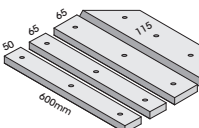
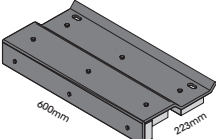
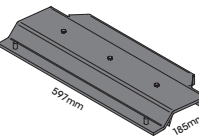
If the promet extension starts to break up and pieces fall into the firebox it must be replaced.

Model	Type of promet required / Type of steel baffle(s) required			Wetback options
<ul style="list-style-type: none"> • Xtreme Rad • Xtreme Rad Base • Xtreme Rad Woody • Xtreme Ped 	<p>Xtreme/R2 Promet Set 500-2010</p> 	<p>Xtreme/R2 Front Baffle 500-2510</p> 	<p>Xtreme/R2 Rear Baffle 500-2515</p> 	<p>3kW Wetback 450-0100</p> 
<ul style="list-style-type: none"> • Mega Rad 	<p>Mega Rad Promet Set 500-2020</p> 	<p>Mega Rad Front Baffle 500-2530</p> 	<p>Mega Rad Rear Baffle 500-2535</p> 	<p>3kW Wetback 450-0100</p> 
<ul style="list-style-type: none"> • LTD Wee Rad • LTD Wee Rad Base • LTD Wee Rad Woody 		<p>LTD Small Promet 500-1700</p> 	<p>LTD Small Baffle 500-2600</p> 	<p>3kW Wetback 450-0100 or 4kW Wetback 450-0150</p> 
<ul style="list-style-type: none"> • LTD Xtreme Rad • LTD Xtreme Rad Base • LTD Xtreme Rad Woody 		<p>LTD Large Promet 500-1850</p> 	<p>LTD Large Baffle 500-2650</p> 	<p>3kW Wetback 450-0100 or 4kW Wetback 450-0150</p> 
<ul style="list-style-type: none"> • LTD Mega Rad 	<p>Mega Rad Promet Set 500-2020</p> 	<p>Mega Rad Front Baffle 500-2530</p> 	<p>Mega Rad Rear Baffle 500-2535</p> 	<p>3kW Wetback 450-0100 or 4kW Wetback 450-0150</p> 

Metro wood fire specifications

Metro have a Specifications Brochure available which details relevant compliance data for every model. This brochure is updated annually and details the minimum clearances and specifications for all models, which is generally required when applying for a building consent. See your Metro retailer to obtain a copy, or visit www.metrofires.co.nz

metrofires.co.nz

Visit the Metro website: metrofires.co.nz to view Metro's 'video demos' showing the latest in wood fire technology energy saving options. You can view the entire Metro product range, find out where your nearest Metro retailer is located or simply check out the latest specifications, installation requirements and emission and efficiency data for the Metro of your choice.



Pioneer heating accessories

Pioneer/Metro Fires offer a range of heating accessories designed to compliment your Metro wood fire. See below for some of the products within our heating accessory range. The range of accessories includes floor

protectors, heat transfer systems, child guards, baffles, bricks and more. For further details ask your Metro retailer for a copy of the Pioneer/Metro Fires heating accessories brochure, or visit www.metrofires.co.nz



ECO Flue Systems

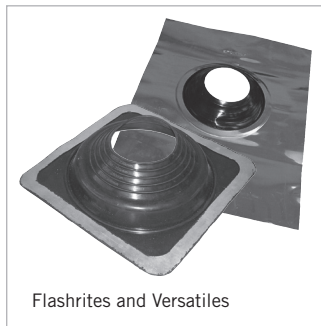

Flashrites and Versatiles



Wetbacks



High Temperature Paint



Child Guards



Heat Transfer Systems

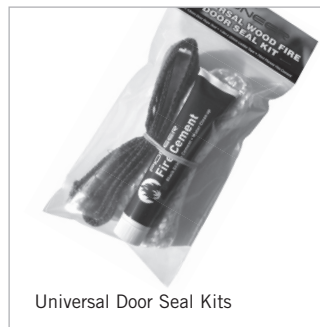

Universal Door Seal Kits



Fire Cement And Silicone



Corner and Wall Floor Protectors



Glass Tape



Door Seal Rope



Chubb Smoke Detectors



Sheetmetal Fabricated Products Ltd.

150 MM FREE STANDING WOODFIRE FLUE KIT INSTALLATION INSTRUCTIONS

WARNING: THIS FLUE KIT HAS BEEN MANUFACTURED IN ACCORDANCE WITH AS/NZS 2918:2001 AND TESTED TO APPENDIX F. TO ENSURE SAFETY THIS FLUE KIT MUST BE INSTALLED AS OUTLINED IN THESE INSTRUCTIONS AND THE APPROPRIATE REQUIREMENTS OF THE RELEVANT BUILDING CODE OR CODES. WOOD FIRE AND FLUE CLEARANCES FROM COMBUSTIBLE WALLS MUST BE IN ACCORDANCE WITH WOOD FIRE MANUFACTURER'S SPECIFICATIONS AND AS/NZS 2918:2001. THESE INSTALLATION INSTRUCTIONS ARE FOR TESTED APPLIANCES ONLY.

CAUTION: MIXING FLUE SYSTEM COMPONENTS FROM DIFFERENT SOURCES OR MODIFYING THE DIMENSIONAL SPECIFICATION OF COMPONENTS MAY RESULT IN HAZARDOUS CONDITIONS. WHERE SUCH ACTION IS CONSIDERED, THE MANUFACTURER SHOULD BE CONSULTED IN THE FIRST INSTANCE.

CAUTION: IT IS THE RESPONSIBILITY OF THE INSTALLER TO ENSURE THAT THE INSTALLATION OF THIS FLUE KIT COMPLIES WITH AS/NZS 2918:2001, THE APPLIANCE MANUFACTURERS SPECIFICATIONS FOR FLUE PIPE SHIELD AND CEILING PLATE AND THAT THE RELEVANT BUILDING CODES ARE ADHERED TO.

BENDS AND EXTENSIONS TO THE LENGTH OF A FLUE SYSTEM ARE PERMITTED (AS/NZS 2918 2001 4.1)

- 1) Locate Wood Fire in its proposed position and mark a point on the ceiling that is directly above the centre of the Wood Fire's Flue Spigot. Check that the Wood Fire's location allows the OUTER CASING to clear all structural roof timbers.
- 2) Cut a 250mm square hole in ceiling. Directly above cut a hole in roof to accommodate OUTER CASING.
- 3) Fit timber nogs around ceiling. i.e. Nogs form a 250mm square aperture that allows air to circulate freely over the OUTER CASING surface.
- 4) Position the OUTER CASING so that it is flush with the underneath of the ceiling and protrudes through the roof the required height. Note that AS/NZS 2918:2001 4.9.1(a) states, "the FLUE PIPE shall extend not less than 4.6m above the top of the floor protector". Refer to diagram B.
 - a) If the FLUE PIPE is within 3 metres of the ridge, the FLUE PIPE must protrude at least 600mm above the ridge of the roof.
 - b) If the distance from the ridge is more than 3 metres, the FLUE PIPE must protrude at least 1000mm above roof penetration.
 - c) The FLUE PIPE must be more than 3 metres from any nearby structure. (Refer diagram C).

Additional FLUE PIPE, OUTER CASING and/or INNER CASING may have to be added to ensure the following:

- I) The correct minimum roof penetration height.
- II) Sufficient overall height to encase the FLUE PIPE which must extend a minimum of 4.6 metres from the floor protector. Refer diagram B.

Note that the INNER CASING should extend 200mm above roof penetration.

NB: Do not secure the OUTER CASING SLIP EXTENSION onto the OUTER CASING, as final adjustment will be required when fitting cowl assembly. See Paragraph 11.

- 5) Fix an appropriate flashing around the OUTER CASING to seal onto the roofing material. Refer to the manufacturer's recommendations for correct fitting. NB: On iron roofs, fixings such as metal angle brackets (approximately 25mm x 25mm) can be fitted under the flashing to securely fix the roof to OUTER CASING.
- 6) Drill holes in ceiling plate for the fixing screws. Place CEILING PLATE over Wood Fire's Flue Spigot, ensuring the folded edges are facing the ceiling.
- 7) Position bottom length of FLUE PIPE (crimped end downwards) into Wood Fire Flue Spigot.

Refer to the supplier of the Wood Fire and use flue pipe sealant if recommended.
- 8) Assemble FLUE PIPES together ensuring seams are straight, offsetting the seams will ensure a neat fit. FLUE PIPES **must** be assembled with crimped ends down (towards Wood Fire). Secure each joint with a minimum of three Monel Steel rivets equally spaced around the joint. If using HI-THERM FLUE PIPE the protective wrapping should be left on the FLUE PIPE during installation.
- 9) From the roof lower FLUE PIPE through OUTER CASING into the bottom FLUE PIPE securing with three monel rivets.
- 10) Check that the FLUE PIPE SPACING BRACKETS inside the INNER CASING are correctly positioned and then from the roof slide the INNER CASING into the OUTER CASING until the brackets rest on to the internal swage ring of the OUTER CASING, this will ensure the INNER CASING is the correct 12mm above ceiling level.

Check the INNER CASING when correctly positioned extends a minimum of 200mm above the roof penetration.
- 11) Before securing the OUTER CASING SLIP EXTENSION to the OUTER CASING with 3 rivets, ensure the FLUE PIPE extends above the top of the OUTER CASING SLIP EXTENSION 145mm. Adjust SLIP EXTENSION to obtain this measurement.
- 12) Fit TOP SPACER BRACKET to the FLUE PIPE making sure the lugs fit snugly inside OUTER CASING SLIP EXTENSION. Make sure TOP SPACER BRACKET fits hard down onto OUTER CASING SLIP EXTENSION.
- 13) Fit CASING COVER over the FLUE PIPE and push down firmly onto TOP SPACER BRACKET.
- 14) Fit COWL but do not secure, as removal for flue cleaning will be necessary. Deform or ovalise the stub of the COWL to ensure it is a tight friction fit.
- 15) Fasten CEILING PLATE to ceiling using screws and ceramic spacers provided. Ensure an even air gap around FLUE PIPE when fixing. Remove protective plastic from CEILING PLATE. N.B. 12mm air gap between ceiling plate and ceiling must be maintained.
- 16) Leave all installation and operating instructions with the owner.

Cleaning of Flue Pipes before lighting the fire.

Stainless Steel pipe should be wiped clean using a soft cloth and methylated spirits to remove finger marks and oils used to manufacture the flue pipe.

Hi-Therm flue pipe can be touched up using only STOVE BRIGHT aerosol paint.

Sheetmetal Fabricated Products Ltd.

150mm Free Standing Wood Fire Flue Kit Installation Instructions Complies with AS/NZS 2918:2001

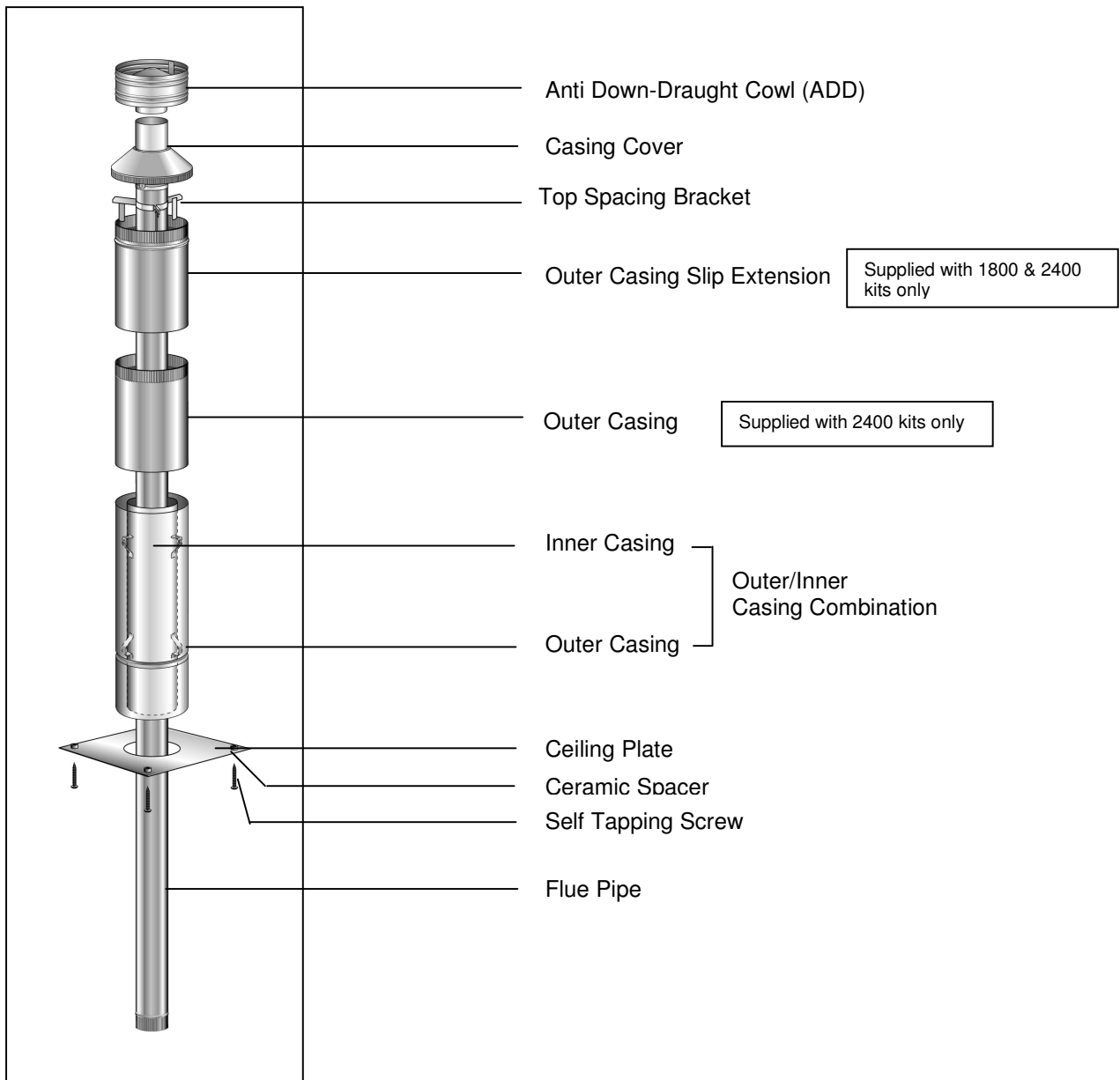

Diagram C AS/NZS 2918:2001 pg 37

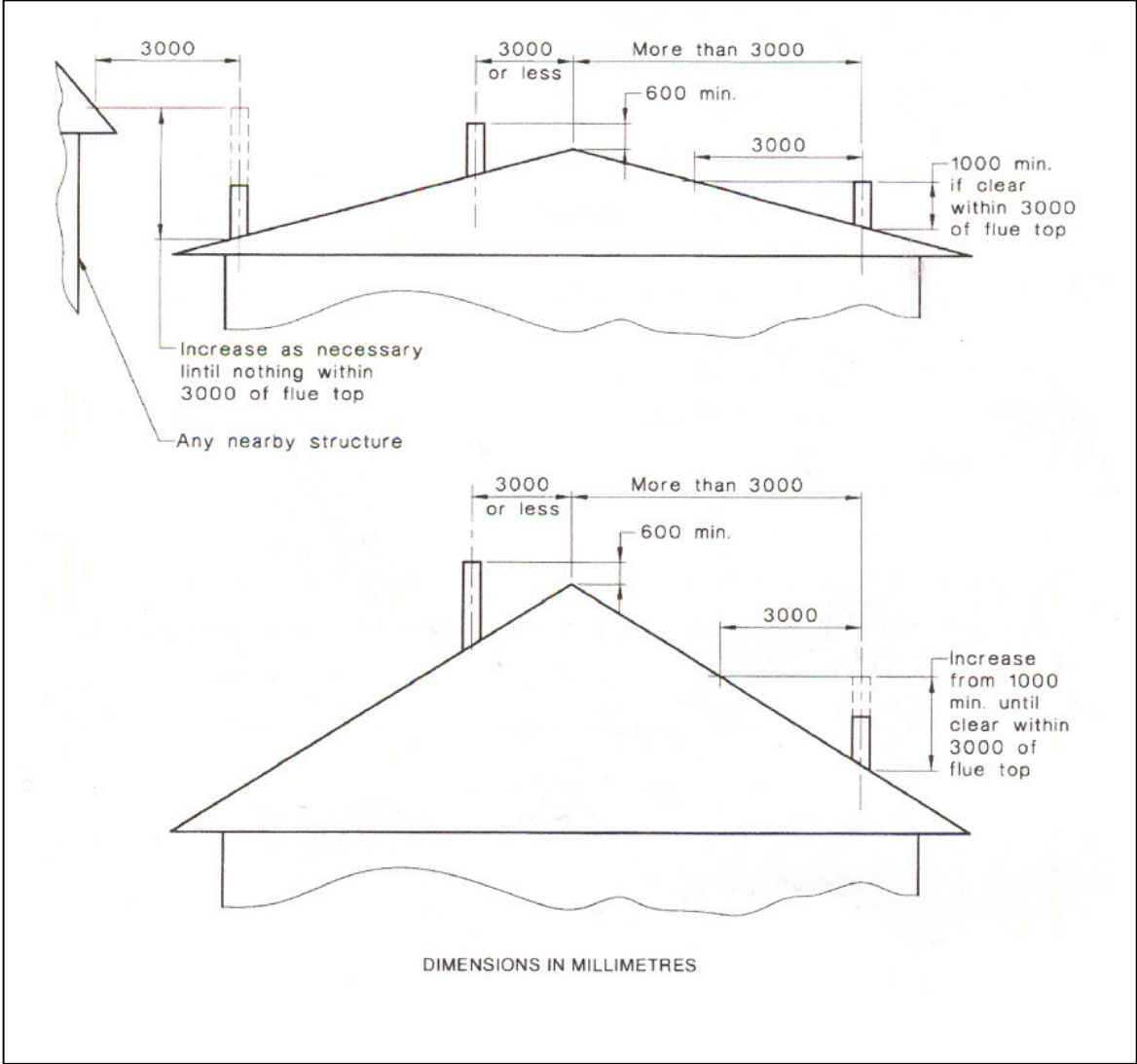
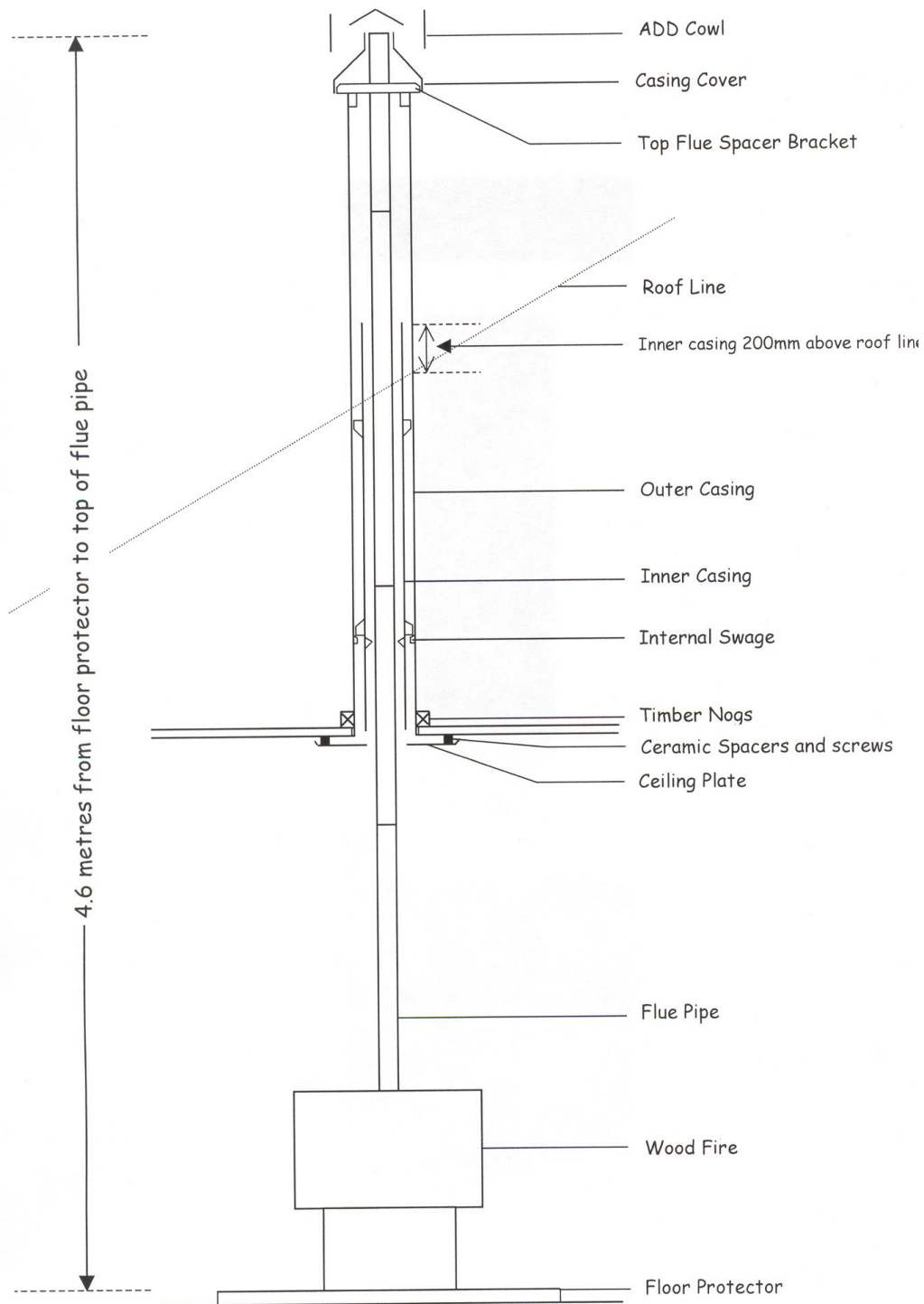

Diagram B



HI-THERM STAINLESS STEEL FLUE PIPES

HI-THERM Flue Pipe is a high temperature, matt finish Flue Pipe designed for use on slow combustion, solid fuel heaters.

HI-THERM Flue Pipe is ideal for heaters that have high flue temperatures and that also can be operated under circumstances that may produce creosoting of Flue Pipes for short periods of time, ie, on refuelling and with air control in shut or low position. Clean air guidelines must be observed.

- HI-THERM Flue Pipe is a **maintainable** product.

CONDITIONS OF USE

- *The Wood Fire must be operated in accordance with the manufacturer's instructions. Clean air guidelines and regulations must be observed.*
- *HI-THERM Flue Pipe must be swept by mechanical means only. (We recommend mixed head or polypropylene brushes). Under NO circumstances should chemical flue cleaners, (soot destroyers) or steel chimney brushes be used.*
- *HI-THERM Flue Pipe should not be used on a Wood Fire burning treated or wet (unseasoned) wood. **Only use newspaper when lighting the fire; never burn colour printed brochures or junk mail.***
- *HI-THERM Flue Pipes **must** be secured together with a minimum of three Monel Steel rivets equally spaced around the joint.*
- *The paint finish appearance may change, depending on Wood Fire operation and is designed to be a MAINTAINABLE finish. To maintain paint finish or touch up use only genuine STOVE BRIGHT Aerosol. (Refer label on packaging).*
- *HI-THERM Flue Pipe must be installed in accordance with SFP installation instructions, using flue componentry supplied by SFP. It is the responsibility of the installer to ensure no water leaks into the Hi-Therm Flue System.*
- *The Stainless Steel Flue Pipe used in "Hi-Therm Stainless Steel Flue Pipe" is warrantied for five years, providing the above conditions are met.*

**FAILURE TO OBSERVE THESE CONDITIONS
MAY NEGATE WARRANTIES**

Pioneer Double Flue Shield - Side extensions

Some Metro models have undergone additional testing which allows for reduced clearances when side extensions are fitted to the Pioneer Double Flue Shield. The Pioneer Flue Shield side extensions are fitted to the Pioneer Double Flue Shield as detailed below.

The side extensions locate on both left and right hand sides of the flueshield. When fixing the side extensions to the Pioneer Double Flue Shield, ensure you have the black face of the side extension facing outwards with the 40mm return edge facing toward the front of the wood fire. Each side extension can be fixed to the outer skin of the Pioneer Double Flue Shield using either stainless steel rivets or a suitable fastening in the suggested fixing points as illustrated.

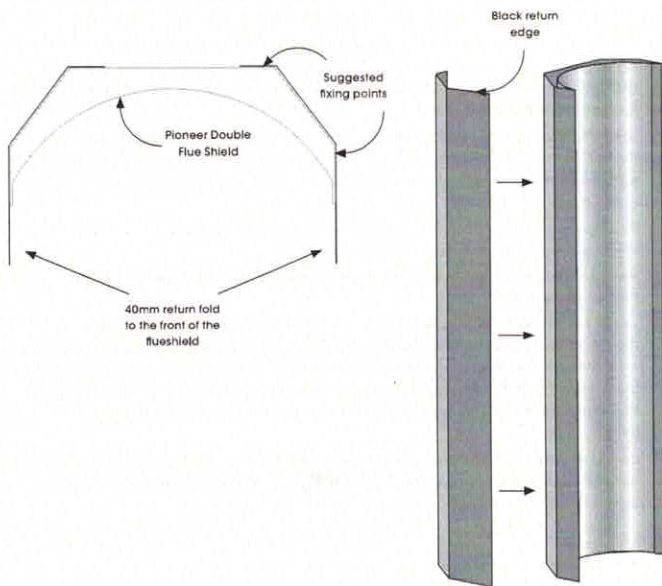

Pioneer Universal Double Flue Shield

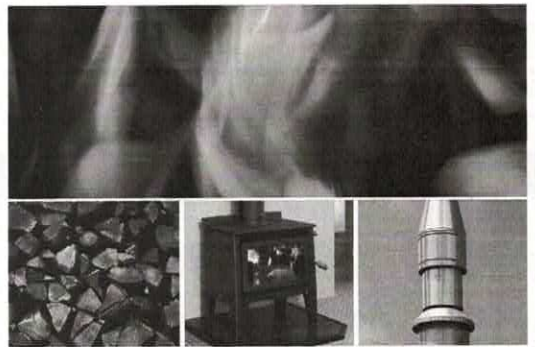

PIONEER

Flue Shield Fitting Instructions

Pioneer Double Flue Shield

This flue mounted shield is a universal design with two alternative lower mounting brackets enabling it to be fitted to any brand wood fire. The highly reflective stainless steel inner shield and vented cavity between rear and inner shields ensures maximum shielding of walls directly behind the installed appliance. Due to its compact design, if minimum side clearances specified with your wood fire are necessary this may require the side depth of the flue mounted shield to be extended with optional side extension panels. Refer to the specifications supplied with your wood fire or consult your wood fire retailer.

Parts and assembly

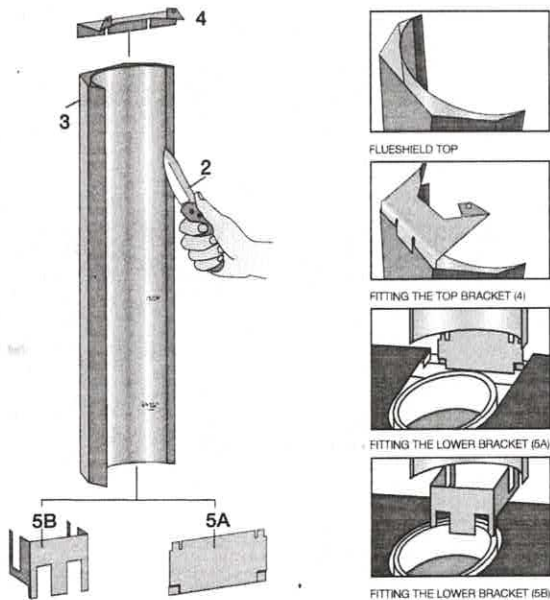

Double Flue Shield fitting instructions

1. Unpack the Flue Mounted Shield, detach the three brackets and familiarise yourself with the illustrations.
2. Using a sharp knife or razor blade, carefully cut through the plastic film on the "inside face" where it meets the outer shield (refer sketch). Cut along the full length of the flue mounted shield on both sides, then peel off and fully remove the plastic film from the stainless steel inner shield.
3. Peel back and fully remove the plastic film from the outer shield.
4. Fit the top bracket to the flue mounted shield as illustrated ensuring the rear mid section of the bracket fits "outside" while the two outer sections of the bracket fit "inside".
5. Fit the appropriate lower bracket to your wood fire.

Lower bracket "5A" suitable for wood fires with an inner rear heat shield.

Attach bracket "5A" to the inner rear heatshield directly behind the flue outlet as illustrated on the opposite page. The rear/outer face of the flue mounted shield then locates into the bracket "5A".

Lower Bracket "5B" suitable for all other wood fires without an inner rear heat shield. On certain model wood fires without a raised flue spigot it will be necessary to cut off both the lower outer legs from the bracket "5B" leaving the central tongue to locate inside the flue outlet only.

Two tabs are provided and if folded back at 90 degrees the bracket and flue mounted shield will mount lower onto the appliance.

The flue mounted shield then locates into the two notches provided in bracket "5B" as illustrated.

6. Once the Flue Mounted Shield is fitted in position onto either of the two lower mounting brackets, check to ensure a large gap is not present between the top of the wood fire and the base of the Flue Mounted Shield, as this may result in a hot spot on the rear wall directly behind the flue outlet. If your wood fire has a lift off top grill the Flue Mounted Shield should be raised sufficiently to enable the top grill to be removed.
7. Using the pre-punched holes in the two tabs provided on the top bracket as guides, drill into the flue pipe and secure the top bracket to the flue pipe with two Stainless Steel rivets (not supplied).

3.4.2 Built-in appliance installations

3.4.2.1 General

Built-in appliance installations shall be tested in accordance with Appendix B and they shall comply with the temperature limits of Paragraph B10.

3.4.2.2 Built-in appliance mantelshelves

Unless a specific mantelshelf arrangements have been shown to be satisfactory during Appendix B testing, mantelshelf arrangements specified for fireplace insert appliances may be used.

3.4.3 Freestanding installations installed in fireplaces or masonry enclosures

If an appliance intended for freestanding installation is installed in a masonry enclosure the clearance between the appliance and any heat-sensitive material shall be in accordance with the requirements of Clause 3.4, as appropriate.

NOTE: Installers should be aware that in some circumstances heat sensitive materials may be obscured by masonry.

3.5 STABILITY

An appliance shall be installed with sufficient stability so as not to detract from the intended normal operation of the appliance nor to create a hazard for users of the appliance.

3.6 WATER CONNECTIONS

All water connections to an appliance shall be in accordance with the appropriate requirements of AS 3500.4.1 or NZS 4603 and the regulatory authority, as appropriate.

3.7 ELECTRICAL CONNECTIONS

All electrical connections to and within an appliance shall be in accordance with the requirements of AS/NZS 3000, AS/NZS 3100 or ER 93, and the regulatory authority as appropriate.



3.8 SEISMIC RESTRAINT

Where required by the regulatory authority, provision shall be made for seismic restraint of the floor protector and the appliance. Sufficient restraint shall be provided to resist a seismic loading equal to 0.4 times the mass of the appliance. The load shall be applied horizontally in any direction at the mid-height of the combustion chamber. The appliance shall not move, tilt or be dislodged from its installed position during application of the load.

NOTES:

- 1 The seismic loading is to be applied before the flue system is installed.
- 2 Where the appliance is secured to the floor protector the test is to be applied to the combination at a point approximately 100 mm above the top surface of the floor protector.

Tenancy Services

Smoke alarm requirements



Warmer



Drier



Safer



Warmer, drier, safer homes

www.tenancy.govt.nz | 0800 TENANCY (0800 836 262)

What you need to know

New Requirements for Smoke Alarms
in Residential Rental Properties
came into force on 1 July 2016.



First edition, reprinted in 2015 by Ministry of Business, Innovation and Employment

PO Box 10-729
Wellington
New Zealand

This document is also available on our website: www.tenancy.govt.nz

You can copy all or some of this guide only if you are using it for education or public information, and you say it came from us. You cannot copy any of this guide in any way for commercial use, and you cannot keep it in a retrieval system unless you ask us first.

ISBN 978-0-947524-58-6 (print)

ISBN 978-0-947524-59-3 (online)

Printed in New Zealand on paper sourced from well-managed sustainable forests using mineral oil free, soy-based vegetable inks.

L3 (10/16)

MB13712

Do the new requirements apply to my rental property?

- › If your residential rental property is covered by the Residential Tenancies Act (RTA) the new requirements apply.

Do I have to have smoke alarms in my rental property?

- › Yes, there must be at least one working smoke alarm in within 3 metres of each bedroom door or every room where a person sleeps.
- › In self-contained caravans, sleep outs or similar there must be a minimum of one working smoke alarm.
- › In multi-storey or multi-level homes (including split levels) there must be at least one smoke alarm on each level or storey.

Who's responsible for replacing smoke alarm batteries?

- › Tenants are responsible for changing batteries in smoke alarms that are designed to have the battery changed during their tenancy.
- › Landlords are responsible for ensuring the smoke alarms are working at the beginning of every new tenancy.

What type of smoke alarms are required?

- › From 1 July 2016, if you are installing new smoke alarms or if you are replacing an existing smoke alarm, you must install photoelectric smoke alarms with long life batteries that have a life span of at least 8 years.
- › There are many different brands of smoke alarms that meet the new requirements.
- › The smoke alarms must be photoelectric alarms with long life batteries and this will be displayed on the smoke alarm and its packaging.
- › Smoke alarms must comply with one of the following manufacturing standards: Australian Standard AS3786:1993; or equivalent international standard: UL217 (USA), ULCS531 (Canada), BS5446: Part 1 (United Kingdom), BS EN 14604 (United Kingdom) or ISO12239 (International) – this should be prominently displayed on the packaging and on the alarm.
- › If in doubt ask, the hardware retailer can advise which smoke alarms comply with the required standards.

Where can you purchase long life photoelectric smoke alarms?

- › You can purchase long life photoelectric smoke alarms from any of the national hardware chains or your local hardware store.

There are smoke alarms installed but they are not long life photoelectric smoke alarms, do they need to be replaced?

- › If the alarms are in the required locations you do not have to replace them until they pass their recommended replacement date or they stop operating.
- › In many cases the replacement date will be listed on the alarm. If there is no replacement date on the alarm, the alarm is more than 8 years old, or you don't know how old the alarm is, you will need to replace the alarm to be certain you are complying with the regulations.

There is a hard wired alarm installed in my rental property, is this okay?

- › Yes, hardwired smoke alarms are an acceptable alternative and the same requirements that apply to photoelectric alarms also apply to hardwired alarms.
- › The hardwired system must have sensors in each bedroom (or boarding room) or within 3 metres of each bedroom door and there must also be at least one smoke alarm installed on each storey or level.

When will landlords have to replace long life photoelectric smoke alarms?

- › According to the manufacturing standard long life photoelectric alarms must have a service life of at least 8 years under normal conditions and have the date of manufacture marked – you should replace the smoke alarms within 8 years of the manufacture date or earlier if recommended by the manufacturer or if the low battery warning sounds.

Where should smoke alarms be placed?

- › The illustrations below from New Zealand Standard 4514 provide a guide on where to place smoke alarms
- › The NZ Fire Service's website, www.fire.org also provides helpful information on the placement of smoke alarms
- › The residential tenancies regulations set out the minimum requirements for smoke alarms. The NZ Fire Service's recommendation to place smoke alarms in each bedroom and within 3 metres of each bedroom door is not a regulatory requirement, but you may wish to consider following this recommendation.

What requirements apply to boarding houses?

There must be at least one smoke alarm installed in each tenant's boarding room or within 3 metres of the entrance (or main entrance) to each tenant's boarding room.

In addition, a smoke alarm must be installed on each storey or level of the boarding house, even if there isn't a boarding room on that level.

Tenants are responsible for replacing smoke alarm batteries in their rooms.

Landlords are responsible for replacing smoke alarm batteries in common areas like hallways and the kitchen.

Illustrations highlighting best practice for installing smoke alarms in homes with particular construction styles

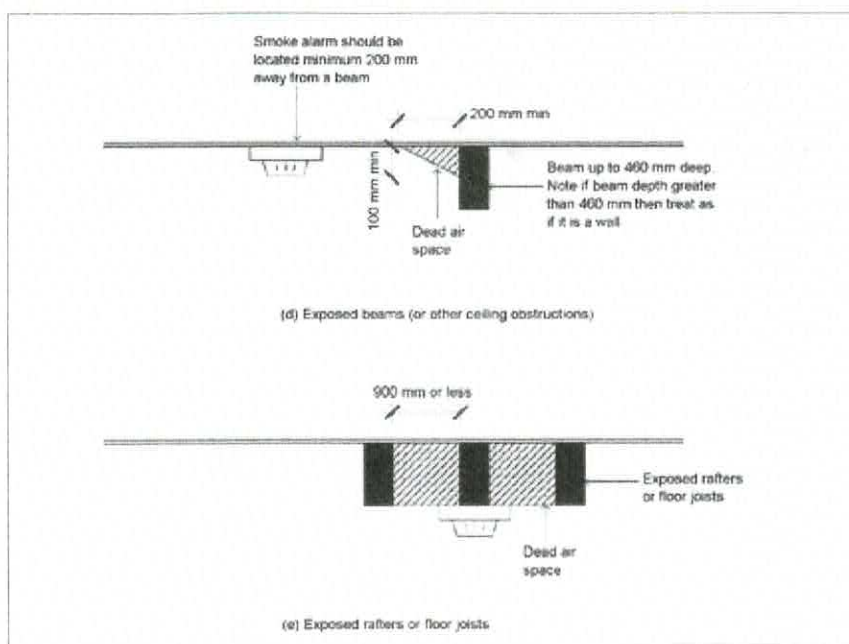

NZS 4514:2009 *Interconnected smoke alarms for houses* © Ministry of Business, Innovation and Employment, administered by the New Zealand Standards Executive. Published with permission from the New Zealand Standards Executive under copyright licence LN001217.

Figure 5.1 Dead air spaces

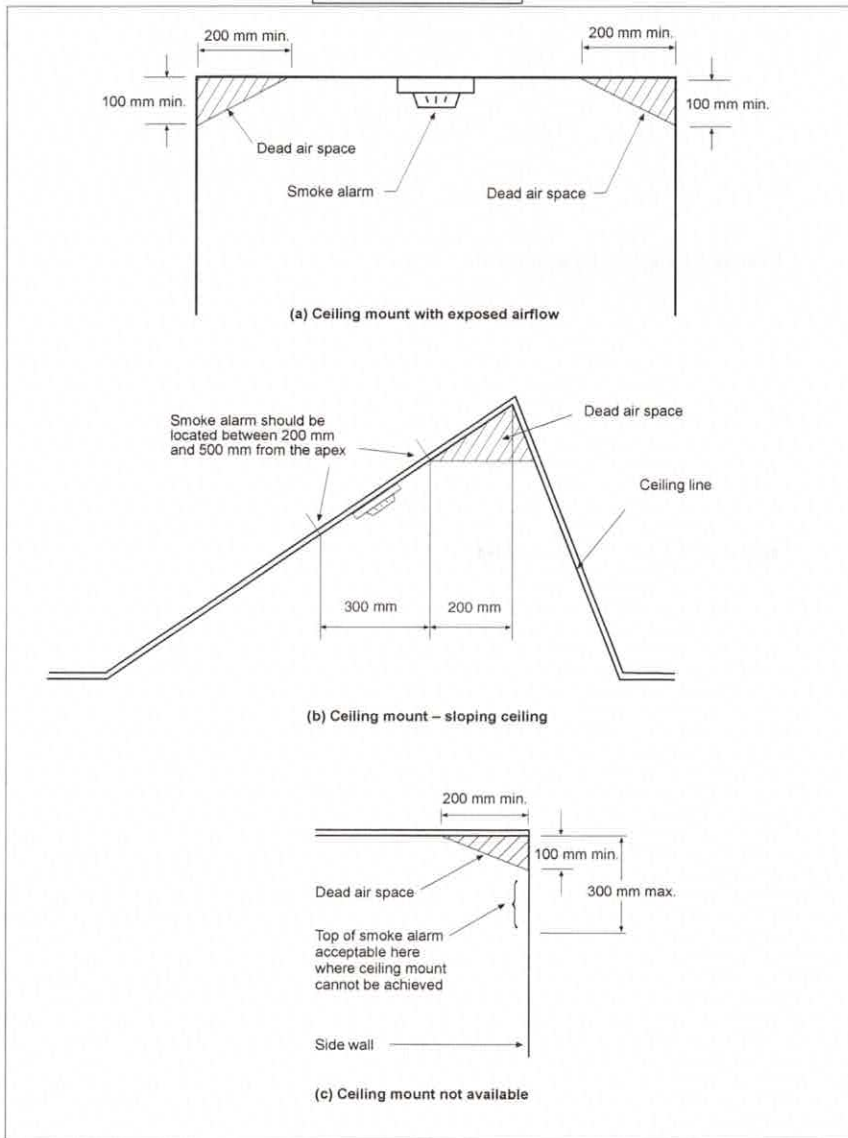

Tenancy Services



Warmer, drier, safer homes

www.tenancy.govt.nz | 0800 TENANCY (0800 836 262)



design features

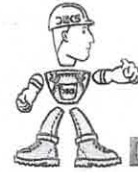

Dektite®

First and the Best!

To develop a product that is universally accepted as the best on the market Dek's consider every aspect of the Dektite® design: installation, functionality and materials.

Success in this is proven by the performance of the Dektite®. The ingenious shoulder moulding, results in less distortion, which reduces stress on the material, and eliminates ponding with complete water run-off in every situation. The low profile not only looks good but provides a generous internal clearance, so even the steepest roofs are handled with ease.

Installation is easier with the Dektite®.

- The large base area provides more coverage and greater latitude in cut-out size.
- The cone has clearly marked cut lines for different pipe diameters.
- Around the base of the cone a flexible bead reduces stress on the flashing membrane (to which an aluminium flange is bonded), as it is formed over the roof profile.
- Underneath, moulded ribbing increases sealant retention to ensure an effective, weatherproof seal.

FLEXIBLE CONE SLEEVE

Dektite® cone shape eliminates seal breakdown due to vibration or expansion and contraction, while isolation of pipe from sheeting dampens noise levels.

EASILY IDENTIFIED SIZING

Pipe diameter rings are clearly marked on the cone sleeve (metric and imperial) for cutting to match the appropriate pipe diameter.

LOW PROFILE DESIGN

Sleek, unobtrusive shape is designed to minimise silhouette on roofline, while managing to provide generous internal clearance for steep, angular installations.

STRESS ISOLATION POINTS

Unique to Dektite® two flexible shoulders absorb distortion and stop transfer of stresses from base to cone, as unit is formed over roofing profile.

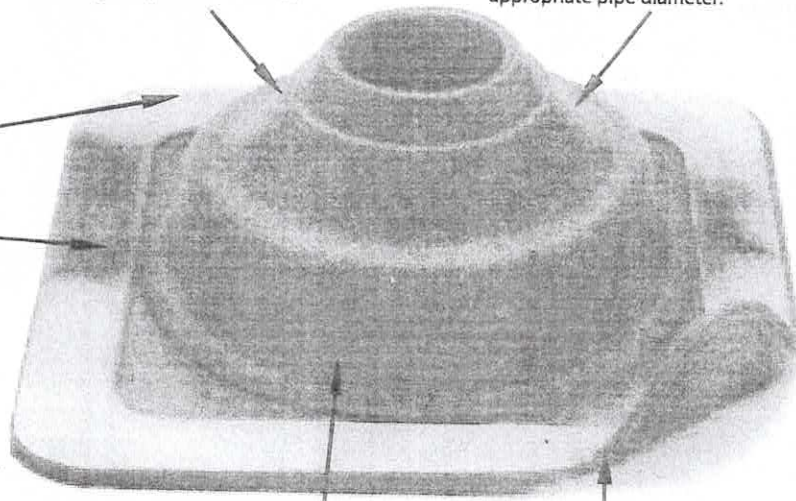

BONDED ALUMINIUM FLANGE

Corrosion-resistant, malleable flange, evenly distributes fastening pressure and allows ease of hand-shaping on most sheet profiles.

INTEGRITY OF FLASHING SHAPE

Minimal distortion after installation, maintains natural flashing shape and seal around pipe, while water run-off is improved and 'ponding' eliminated.

LARGE BASE AREA

For better coverage of penetration cut-out and improved performance over steep roof pitches and a wider variety of cladding profiles.

IMPROVED WATERPROOFING

Designed to strengthen sealant bond and improve waterproofing, the ribbed base has an angled skirting edge to help shed moisture and contribute to a superior waterproof seal. For even more efficient water run off the Dektite® can be fitted on the Diamond.

NEW ZEALAND HOME HEATING ASSOCIATION (INC)
 P O Box 302-486 North Harbour, Auckland 1330
 Ground Floor, 2/106 Bush Road, North Harbour, Auckland
 Phone: 64-09-414-4300 0800 866 667
 Fax: 64-09-414-4593
 E-Mail: nzhha@tradesec.co.nz



MEMO

TO: All Members
FROM: Ed Hawkes National Secretary
SUBJECT: Soaker Flashings
DATE: 3RD May 2005

Department of Building and Housing (DBH) have adjusted Fig 54 (below) to accommodate pipe penetrations up to 500mm diameter. They will also show the roofing sheet above the flat flashing to be a separate sheet rather than a 'slit' sheet as implied in the document to date. This will be published in the reprint of the Building Code June/July, 2005.

(4) Suitable only for roof pitches of 10° or higher.

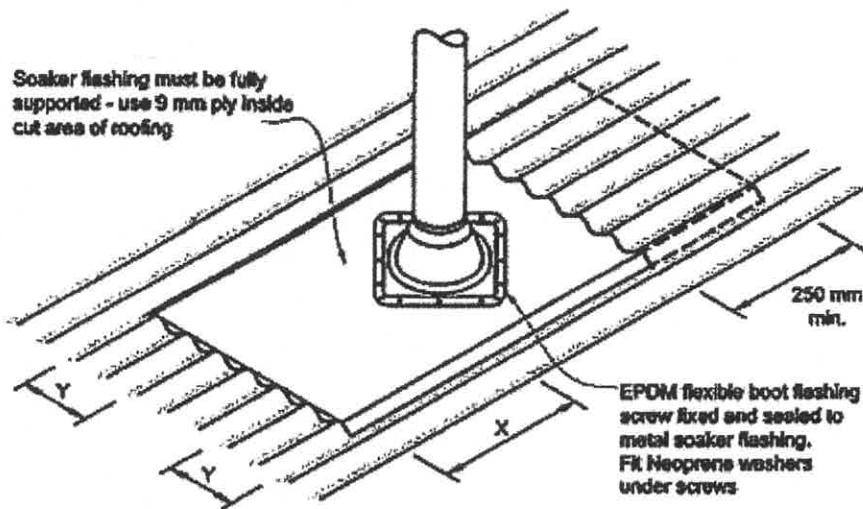

MINIMUM HEIGHT OF FLUE SYSTEM OUTLET

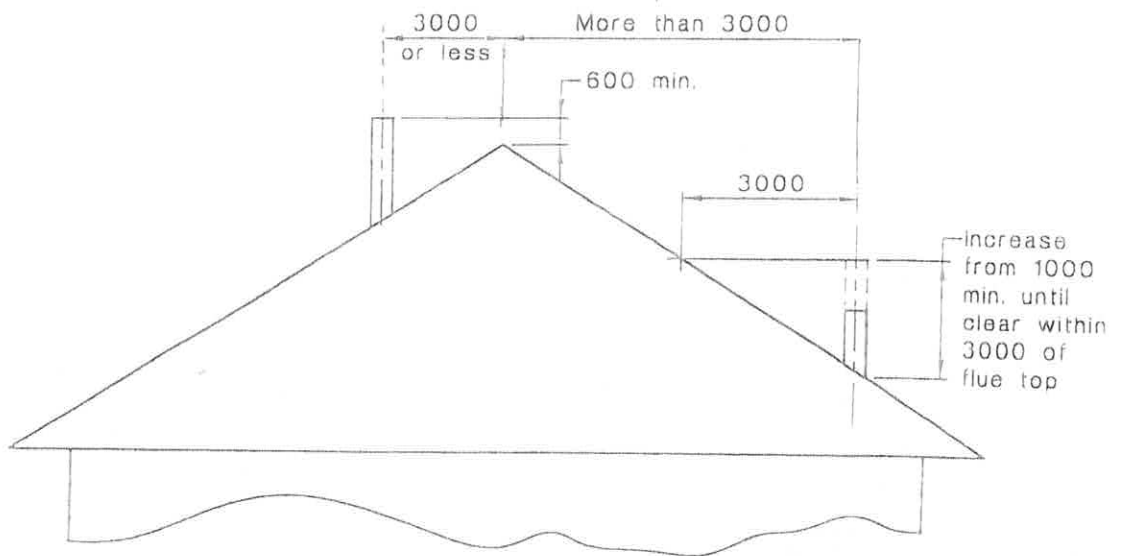
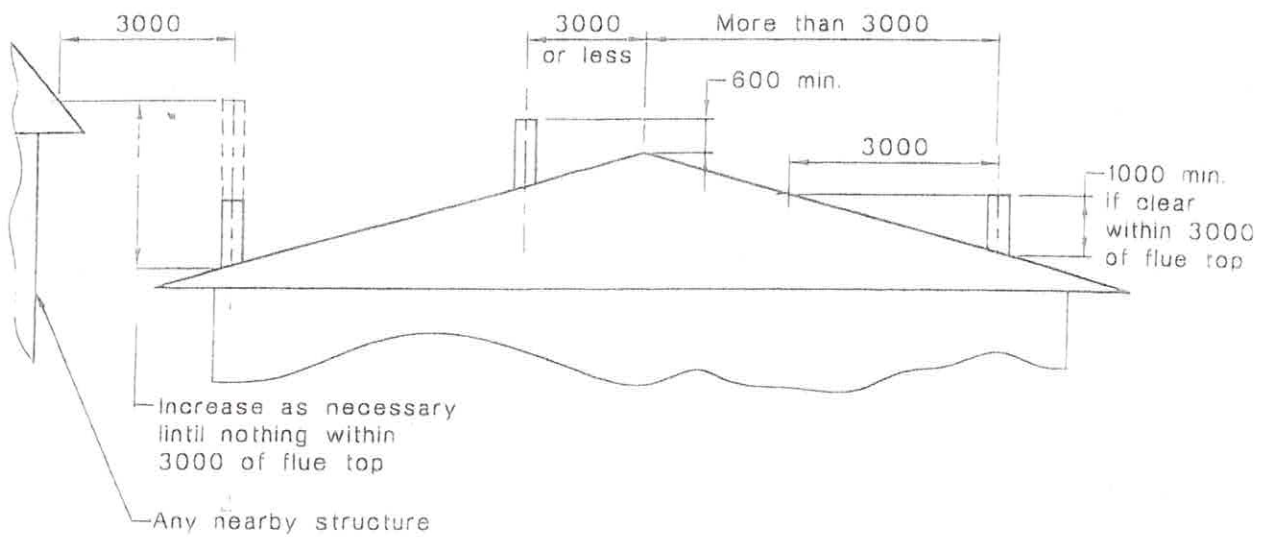

DIMENSIONS IN MILLIMETRES

NOTES:

1. The flue pipe shall extend not less than 4.6m above the top of the floor protector.
2. The flue cowl must be at least 600mm above the highest point of the roof if within 3 metres of it, or 1 metre above the roof penetration if more than 3 metres from the ridge.
3. No part of the building, or any adjacent building may be in or above a circular area of a horizontal radius of 3 metres from the flue exit.

PRODUCER STATEMENT

This statement is intended for use by a contractor to provide the Tasman District Council with reasonable grounds for the issue of a Code Compliance Certificate.

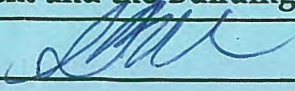
ISSUED BY:	Steve Miller		
MAILING ADDRESS:	21 Crancher St		
POSITION:			
TELEPHONE NO:	5444646		
OWNERS' NAMES:	Nick Herron		
PROJECT LOCATION:	Barnett Ave Best Island		
VALUATION NO:	193809340.0		
LEGAL DESCRIPTION:	Lot No:	36	DP No: 5096
BUILDING CONSENT NO:			
DESCRIPTION OF WORK IN COMPLIANCE WITH THE BUILDING CODE:	EXTENSION OF KITCHEN & PLACEMENT OF WASTES		
WHERE NECESSARY			
ATTACH IDENTIFICATION OF ENGINEER'S REPORTS OR DESIGN PLANS:	<input type="checkbox"/>	YES	<input type="checkbox"/> NO
ATTACH IDENTIFICATION OF THE APPRAISED ITEMS OR INSTALLATION METHOD:	<input type="checkbox"/>	YES	<input type="checkbox"/> NO
INTENDED LIFE:	<input type="checkbox"/>	50 YEARS	<input type="checkbox"/> 15 YEARS <input checked="" type="checkbox"/> 5 YEARS
TERRITORIAL AUTHORITY'S INVOLVEMENT (INSPECTION):			
AT WHAT STAGE:			
DECLARATION:	I believe on reasonable grounds that the work described above will or has been carried out in accordance with the above mentioned building consent and the Building Code.		
SIGNED BY PERSON RESPONSIBLE:			
DATE:	18-12-95		

PRODUCER STATEMENT - CONSTRUCTION REVIEW

I 'Ron O'Hara - Consulting Engineer' have been engaged by the 'Owner/Developer/Contractor' as listed below to provide construction review services with respect to the relevant clauses of the Building Regulations 1992.

I have sighted the building consent (number indicated below) and the attached conditions of building consent.

As an independent design professional I or personnel under my control have carried out periodic reviews of the work appropriate to the engagement and based upon these reviews I believe on reasonable grounds that those parts of the work under the above building consent with respect to the relevant clauses of the Building Regulations 1992 (and as indicated in the section entitled 'Scope of Construction Review' below) have been completed to the extent required by that building consent.

Signed: 

Date: 15-Dec-95

R J O'Hara BE(Civil) MIPENZ Registered Engineer (Reg No 4960)

Address: 210 Hardy St, NELSON

General

Owner/Developer/Contractor

N Herron

Location of Works

Bests Island

Richmond

Legal Description

Lot

DP

Drawings & Specifications by

Owner

Consent Number

Verification Methods / Acceptable Solutions

B1/VM1, B1/AS1

Description of Works

Existing house extension

Scope of Construction Review

Description

Founds-Strip-RC

Bracing-upper storey-walls

Lintel Beams-timber

Roof struct-timber

Codes used

4203, 3101

3604, 3603, 3615

4203, 3603

4203, 3603

Additional comments on observations

I have inspected the site of the house extension, measured the structure including the existing parts of the house, and determined the construction of the extension in discussion with the owner.

Using the information supplied and determined on site I have checked the structure for compliance with NZS 3604:1990, and where the extension structure does not comply have analysed the non-complying components specifically.

While there are no approved bracing panels in the extension, the extension structure does not increase the bracing requirements for the overall house as it falls within the overall house length and width and is of light weight construction not likely to add to the EQ loading for the structure.

The foundation bearing pressure is calculated to be 25 kPa or less, and the foundations are in material capable of considerably greater bearing than this.

The roof structure and exterior window lintel have been checked specifically and are adequate.

This producer statement shall be read in conjunction with the attached sketch plans signed by the owners as being a fair record of the structure as-built.

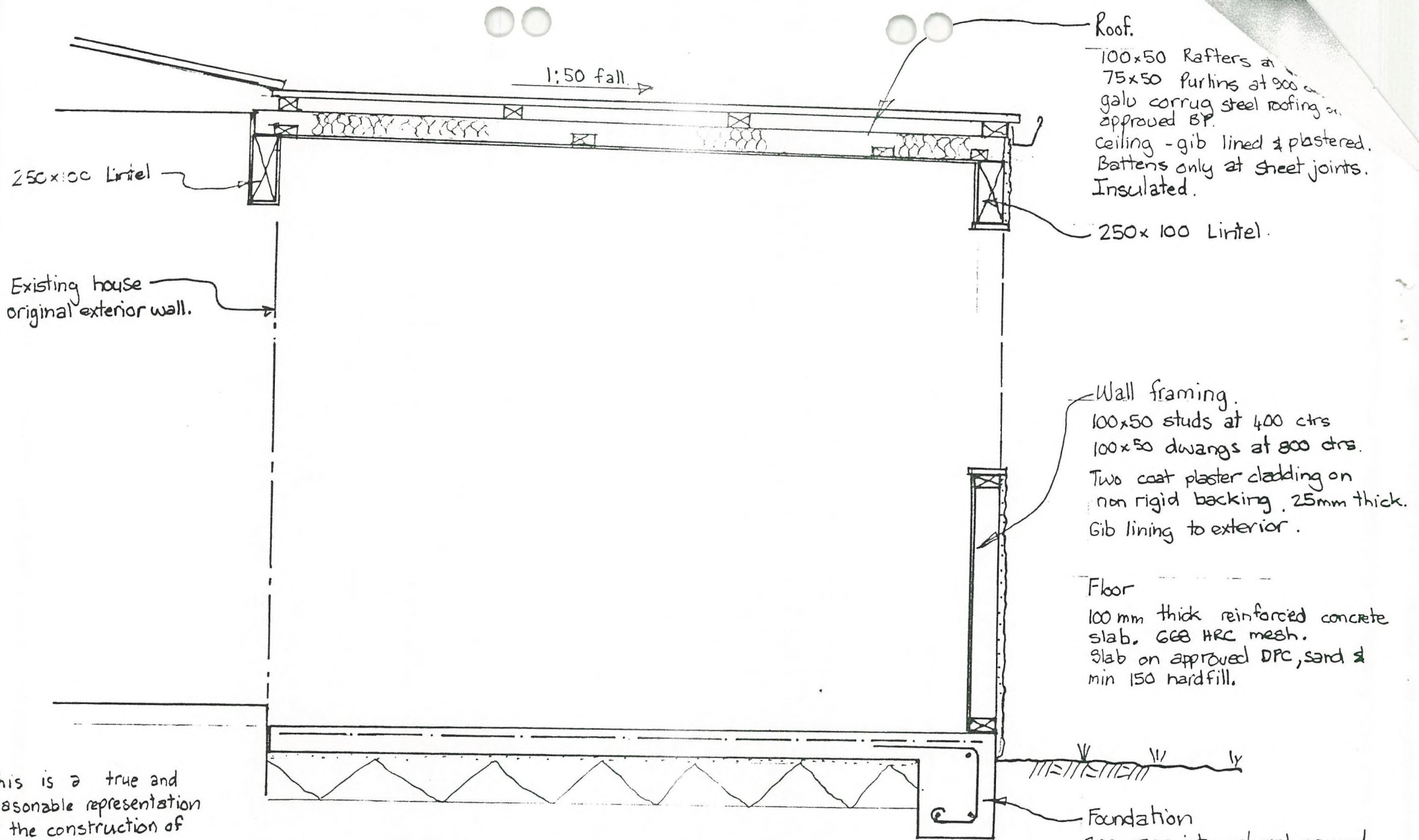

TYPICAL SECTION

1:20 approx.

This is a true and reasonable representation of the construction of the extension.

Signed

N Herron. - Owner
15/12/95

Form 5

Building consent - BC190638

Section 51, Building Act 2004

The building

Street address of building: 117 Barnett Avenue, Best Island
Legal description of land where building is located: Lot 3 DP 533749
Building name:
Location of building within site/block number: 117 Barnett Avenue, Best Island
Level/unit number:

The owner

Name of owner: Kursten Dion Ward and Elke Baumann-ward
Contact person: Jacqui Soffer (property Manager)
Mailing address: 117 Barnett Avenue
RD 1
Richmond 7081

Street address/registered office:

Phone number: Landline: Mobile: 02102959044

Daytime: No information provided

After hours: No information provided

Facsimile number: No information provided

Email address: jacqui.soffer@therentshop.co.nz

Website: No information provided

First point of contact for communications with the building consent authority:

Haidee Doyle (MURRAY SINCLAIR LIMITED); Mailing Address: 128 Tahunanui Drive
Tahunanui

Nelson 7011; Phone: 035485742; Email: office@pmfireplaces.co.nz

Building work

The following building work is authorised by this building consent:

Install freestanding Metro wood burner

This building consent is issued under section 51 of the Building Act 2004. This building consent does not relieve the owner of the building (or proposed building) of any duty or responsibility under any other Act relating to or affecting the building (or proposed building). This building consent also does not permit the construction, alteration, demolition, or removal of the building (or proposed building) if that construction, alteration, demolition, or removal would be in breach of any other Act.

This building consent is subject to the following conditions:

Section 90 - Inspections by Building Consent Authorities: (1) Every building consent is subject to the condition that agents authorised by the building consent authority for the purposes of this section are entitled, at all times during normal working hours or while building work is being done, to inspect-

- (a) land on which building work is being or is proposed to be carried out; and
- (b) building work that has been or is being carried out on or off the building site; and
- (c) any building.

(2) The provisions (if any) that are endorsed on a building consent in relation to inspection during the carrying out of building work must be taken to include the provisions of this section.

(3) In this section, inspection means the taking of all reasonable steps to ensure that building work is being carried out in accordance with a building consent.

Compliance schedule

A compliance schedule is not required for this building.

Inspections

The following inspections are required:

- Final

Documents required

Final

- C: Solid fuel heater - Installers Declaration

Copies of all site reports/records must be provided to the BCA as work proceeds for their records, please upload these to the correct building consent via the AlphaOne portal.

Attachments

Copies of the following documents are attached to this building consent:

- Advice notes / Endorsements

Matt Feely

Position: Interim Building Assurance Manager

On behalf of: Tasman District Council

Issue Date: 13 June 2019

Advice notes / Endorsements

Site Safety - Please ensure all appropriate site safety measures are provided throughout the contract works to comply with NZ Building Code Clause F5 and all occupational safety and health requirements.

Solid Fuel Burning Appliance - It is the owners responsibility to ensure any curtains, drapes or other such combustibles which would present risk of fire are kept tied back so as not to encroach within the safety clearance of the appliance.

Blog ID: 151986

Author: Natural Hazards

Created: 2019-06-06 13:35:46

Notes: Assets Input:Council has no natural hazards concerns with this proposal as it is for the installation of a fire only

Blog ID: 152668

Author: Shane Kelly

Created: 2019-06-13 09:40:27

Notes: Shane Kelly added 'BC Issue Awaiting Invoice' block for the following reason: Invoice Due

Blog ID: 152669

Author: Shane Kelly

Created: 2019-06-13 09:40:27

Notes: Shane Kelly added 'CCC Issue Other' block for the following reason: CCC Not Ready

Blog ID: 152670

Author: Shane Kelly

Created: 2019-06-13 09:40:27

Notes: Shane Kelly added 'Inspections BC Not Granted/Issued' block for the following reason: BC decision to grant has occurred but the BC has not yet been granted/issued. This block will automatically be removed when the BC is granted/issued.

Blog ID: 152730

Author: Sally Blain

Created: 2019-06-13 14:17:32

Notes: Sally Blain removed 'BC Issue Awaiting Invoice' block for the following reason: Invoice 75033 - paid in full - issued

Blog ID: 152731

Author: Sally Blain

Created: 2019-06-13 14:19:10

Notes: Sally Blain removed 'Inspections BC Not Granted/Issued' block for the following reason: BC is now granted and issued

Blog ID: 153516

Author: Krystle Bang

Created: 2019-06-21 11:20:07

Notes: Krystle Bang removed 'CCC Issue Other' block for the following reason: CCC application received

Blog ID: 154383

Author: Julian Malcolm

Created: 2019-07-01 15:31:25

Notes: Julian Malcolm added 'CCC Issue Awaiting Invoice' block for the following reason: Invoice Due

Blog ID: 154384

Author: Julian Malcolm

Created: 2019-07-01 15:31:45

Notes: Julian Malcolm removed 'CCC Issue Awaiting Invoice' block for the following reason: No outstanding fees

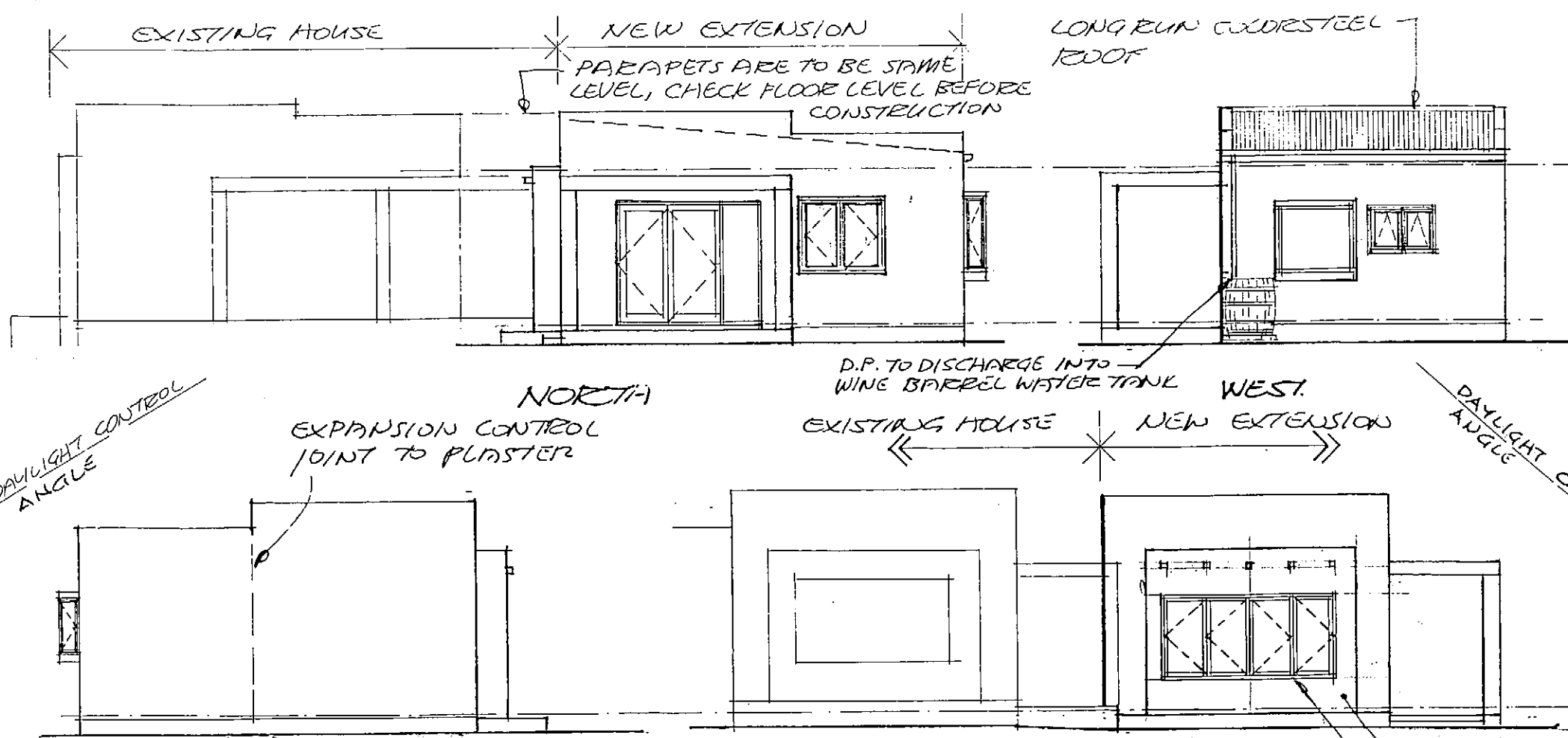

SOUTH ELEVATIONS 1:100

- NOTES:
- CHECK SITE BOUNDARIES & LOCATE DRAWS & CHECK INVERTS, LOCATE UNDERGROUND SERVICES ON SITE PRIOR TO CONSTRUCTION
 - CHECK FOUNDATION DIMENSIONS AS BUILT PRIOR TO CONSTRUCTING PERMANENT FRAMES & TRUSSES.
 - CHECK FRAME DIMENSIONS AS BUILT PRIOR TO CONSTRUCTING JOINERY & FITTINGS
 - ALL CONSTRUCTION SHALL COMPLY WITH THE N.Z. BUILDING CODE & T.D.C. BYLAWS

LEGEND

(A) — BRACING LINE
 (B2) — WALL BRACE NUMBER

— WINDOW HEIGHT x WIDTH
 L 100 x 100 LINTEL SIZE

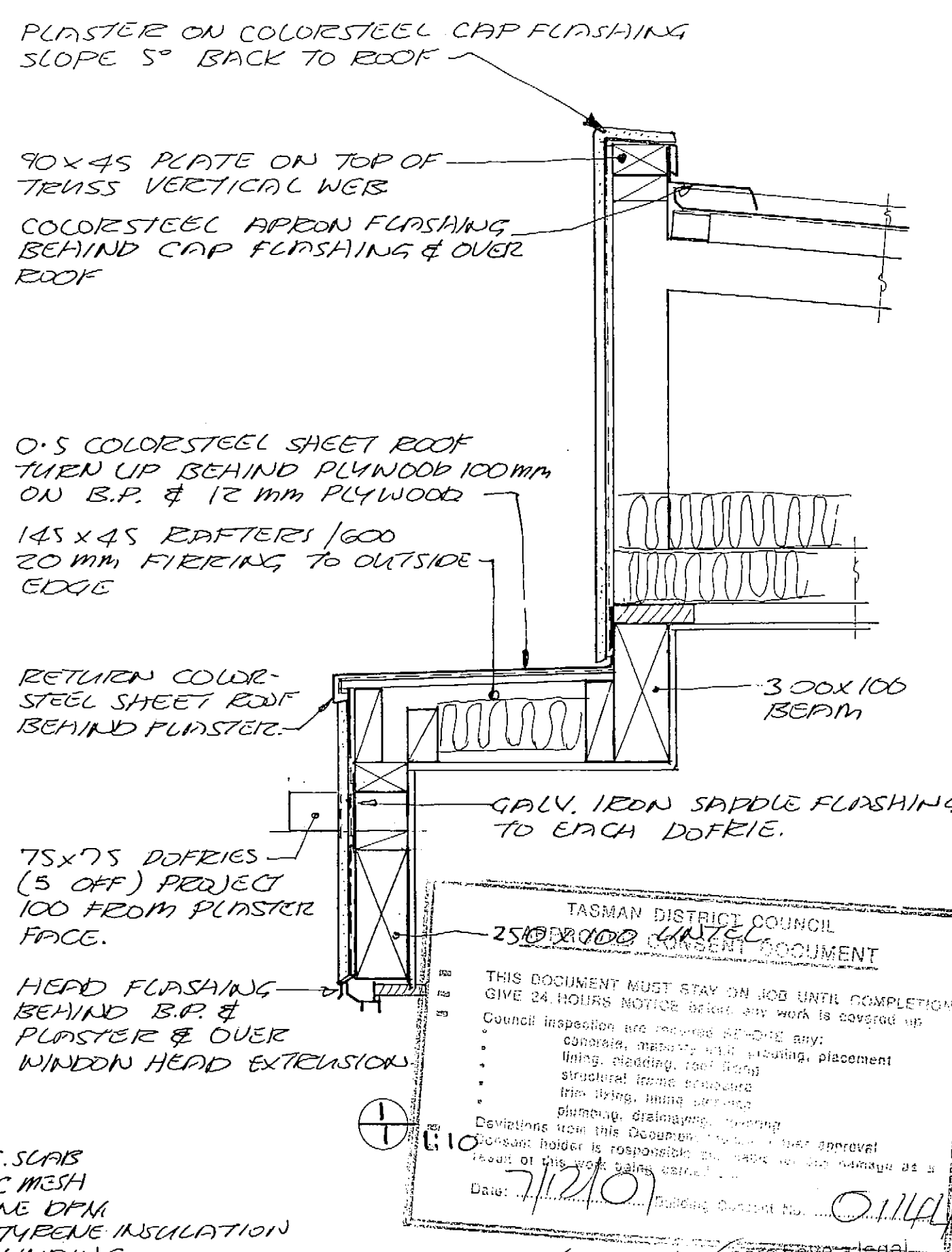
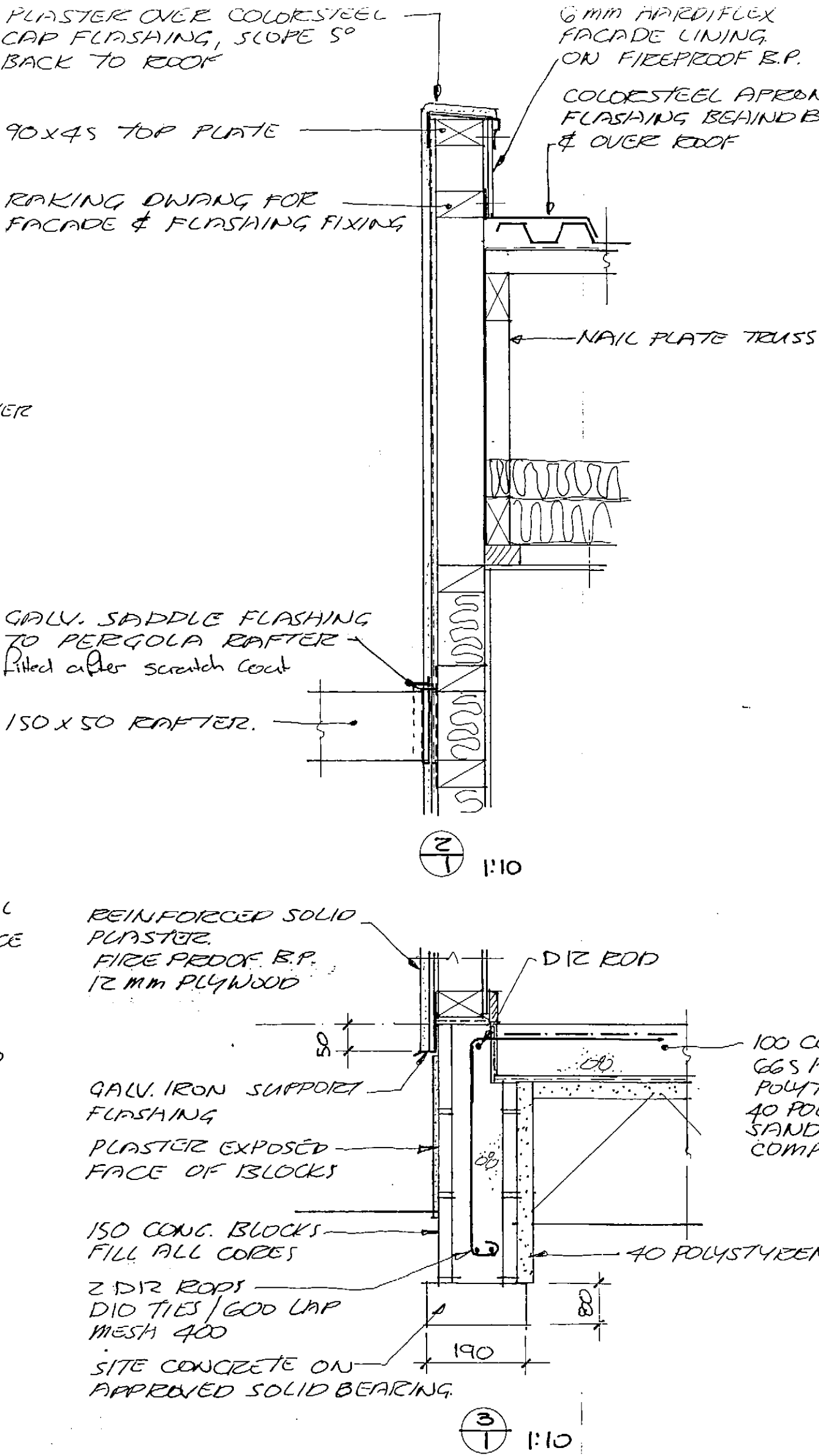
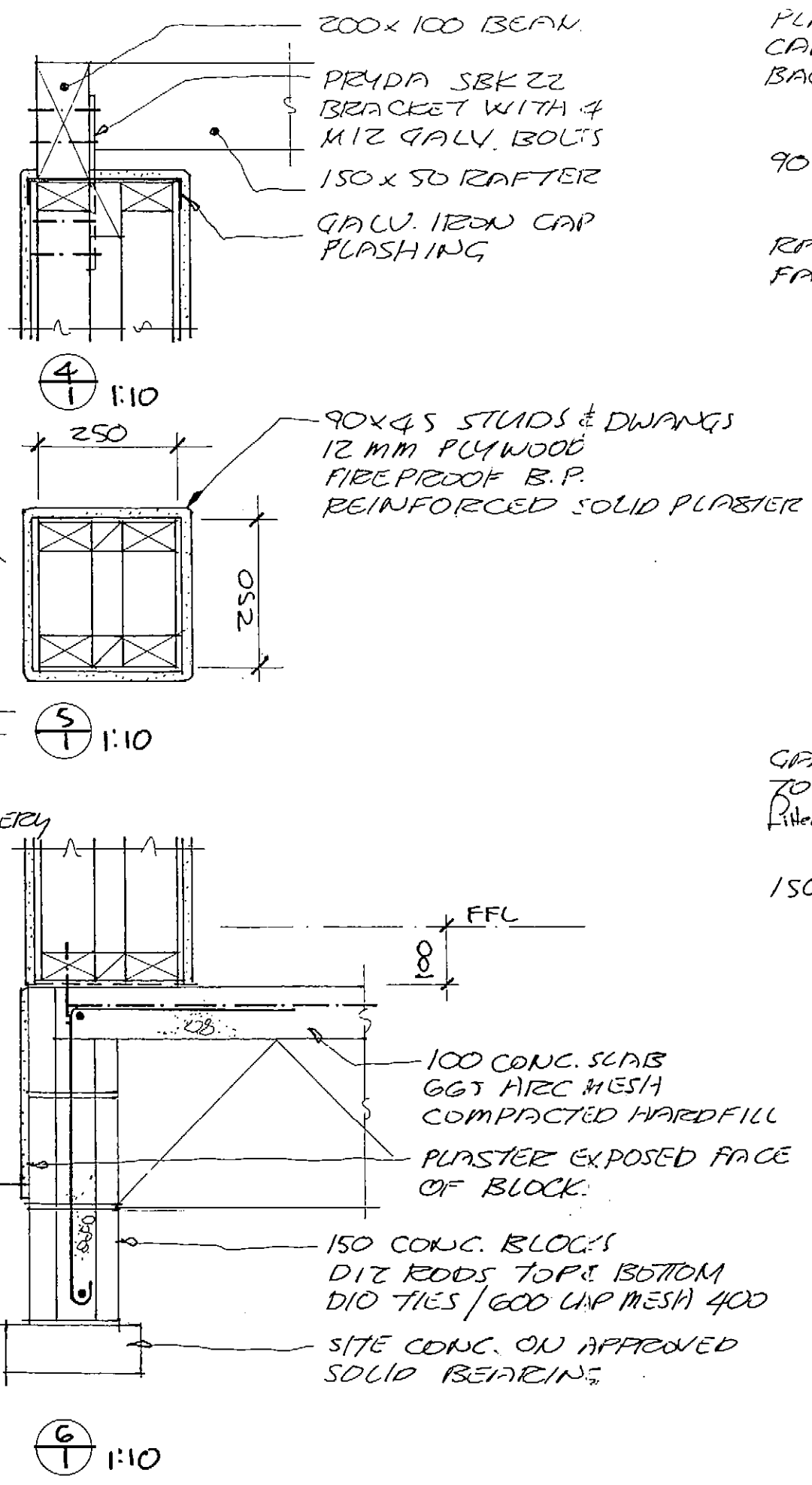

TASMAN DISTRICT COUNCIL
 250 BRIDGES AVENUE
 TASMAN DISTRICT COUNCIL
 THIS DOCUMENT MUST STAY ON JOB UNTIL COMPLETION
 GIVE 24 HOURS NOTICE BEFORE ANY WORK IS COVERED UP
 Council inspection and approval required for:
 • General, structural, plumbing, placement
 • Lining, plumbing, roof, sand
 • Structural frame structure
 • Fire, fire, fire services
 • Plumbing, drainage, heating
 • Drains, holes & manholes, etc. for no damage as a result of this work being carried out.
 Date: 1/12/01

Property owners have a legal obligation under the Plumbers Gasfitters and Drainlayers Act 1976 to have a craftsman plumber and registered drainlayer carry out their appropriate trade. Failure to do so could lead to legal action.

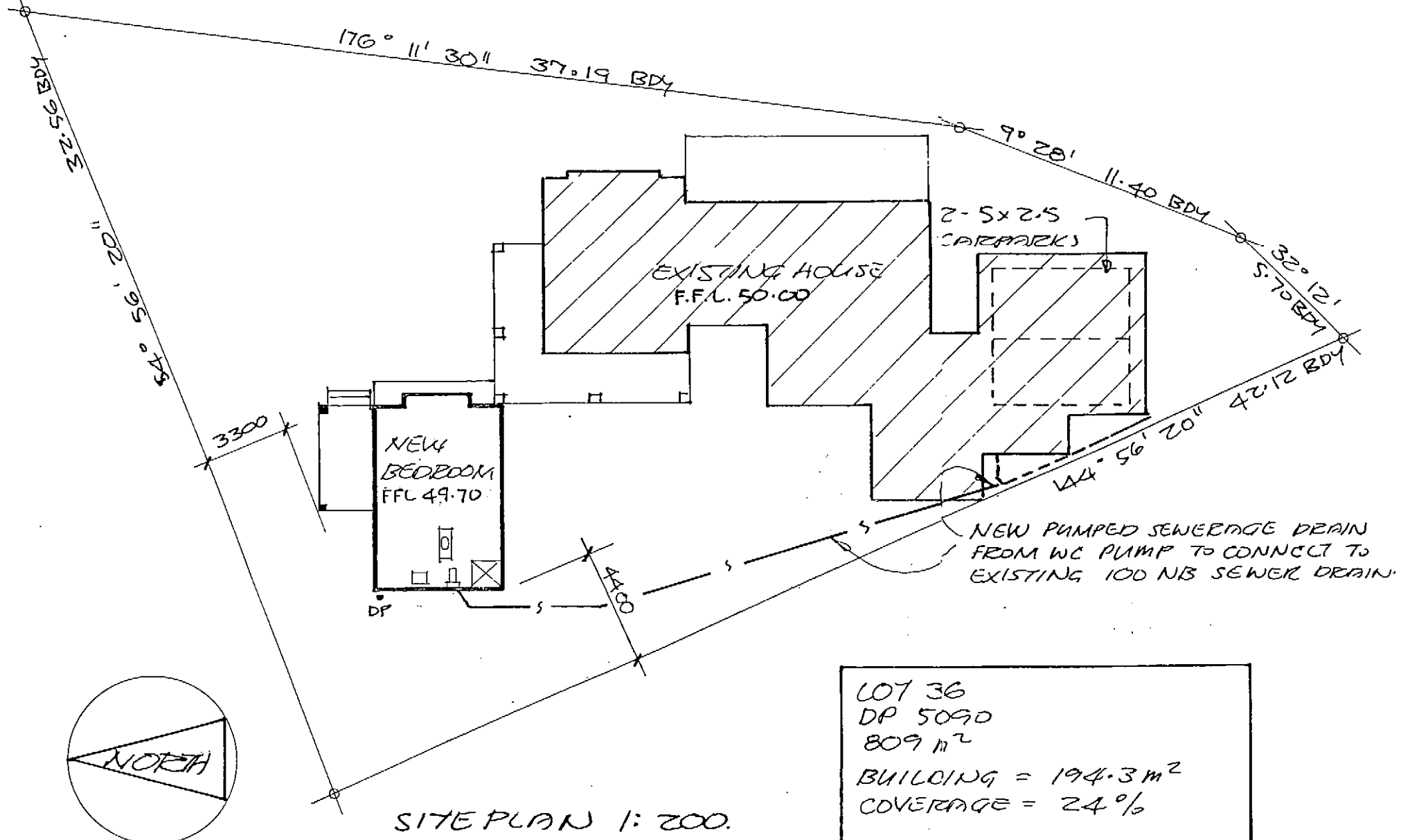

SITE PLAN 1:200

LOT 36
 DP 5090
 809 m²
 BUILDING = 194.3 m²
 COVERAGE = 24%

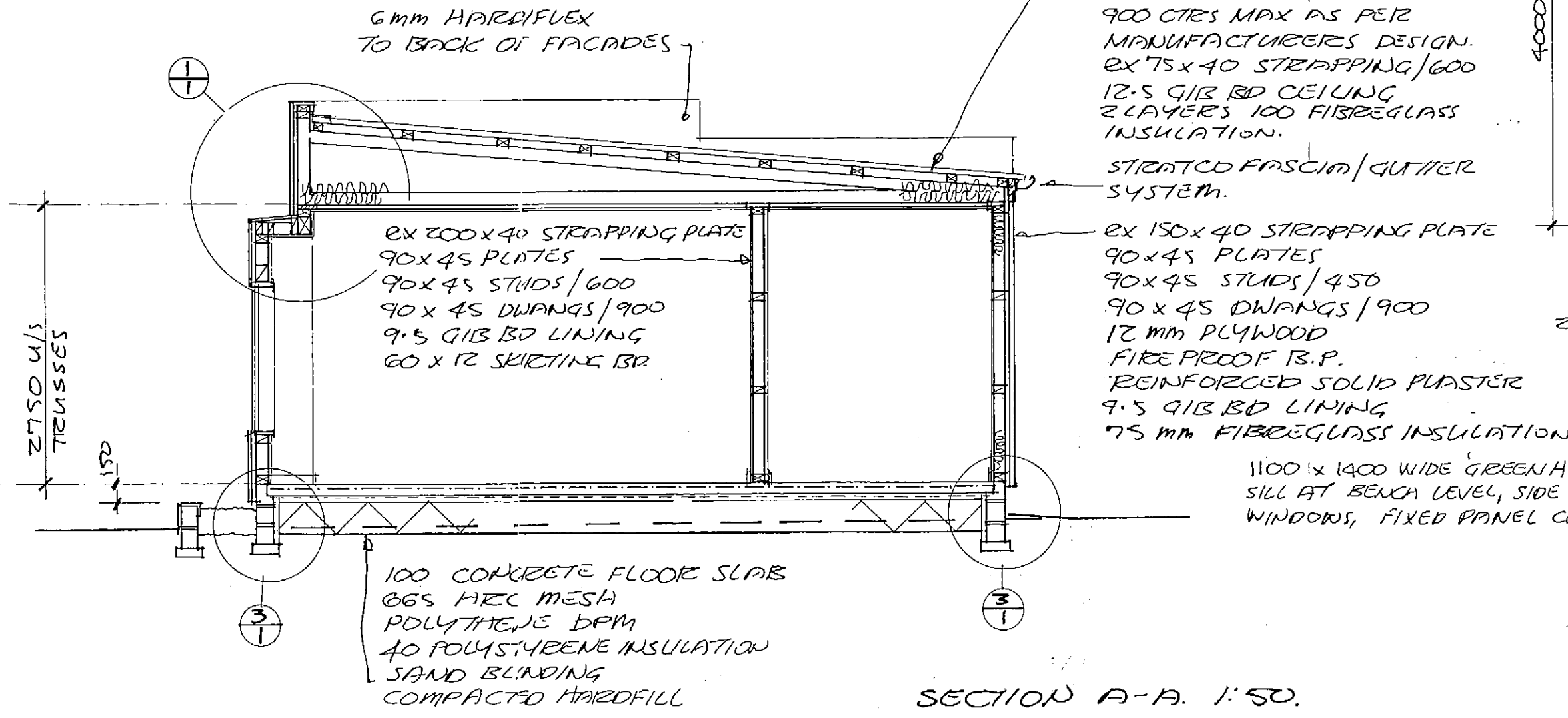

SECTION A-A 1:50

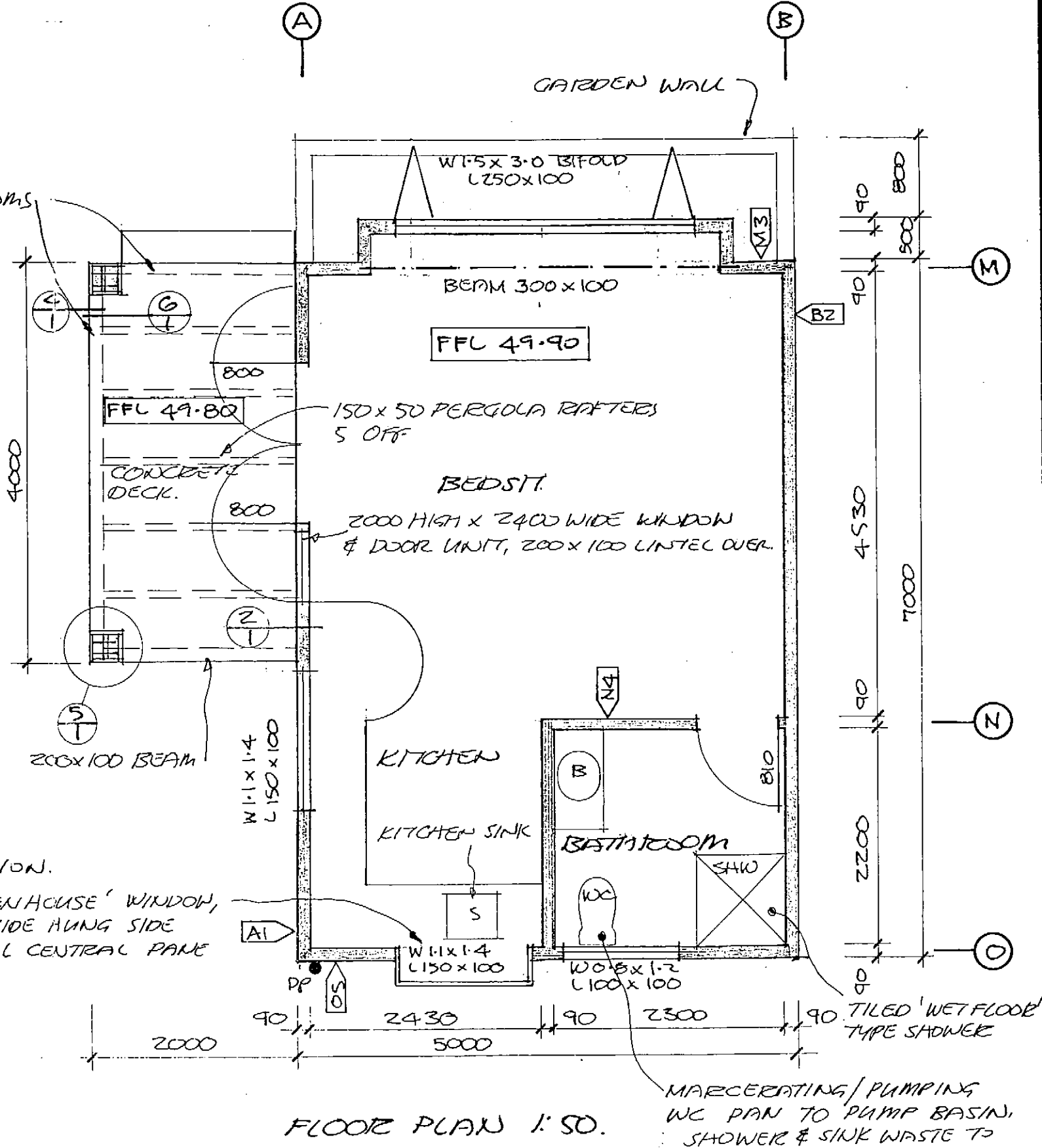

FLOOR PLAN 1:50

MENZIES DESIGNS LIMITED
 ARCHITECTURAL; MECHANICAL
 DRAUGHTING AND DESIGN

PO BOX 2136
 STOKE, NELSON
 PH (03) 5390603
 FAX (03) 5390604

EXTENSIONS TO HOUSE BESTS ISLAND FOR MR C. & MRS L HAWKINS.

DATE	AMENDMENT	CHECKED	0203	SCALES	1:200 1:100	SHEET	1
DRAWN	TM	DATE	29 MAR 01	1:50 1:10		SERIES OF	1
TRACED						REF	A00537

B U I L D I N G C O N S E N T
Section 35, Building Act 1991

Applicant

CHRISTOPHER HAWKINS
BEST ISLAND
RD1
RICHMOND

Consent Details

Consent/PIM No.: 961906
Date issued: 17/12/96
Date of applicn: 5/11/96
Valn No: 1938093400

Project Descrn: ALTERATIONS, REPAIRS or EXTENSIONS
BEING STAGE 1 OF AN INTENDED 1 STAGES
ALTERATIONS TO DWELLING

Intended Life: INDEFINITE, BUT NOT LESS THAN 50 YEARS

Intended Uses: GARAGING AND HOUSING

Project Location: BARNETT AVE, BEST ISLAND

Legal Description: LOT 36 DP5090 BLK II WAIMEA SD

Estimated Value: \$ 49,000

CHARGES: The Council's charges paid on uplifting this Building Consent, in accordance with the attached details, are:

	\$	400.00
Building Research Levy	\$	100.00
Building Industry Authority Levy	\$	65.00
TOTAL:	\$	565.00

This building consent is a consent under the Building Act 1991 to undertake building work in accordance with the attached plans and specifications so as to comply with the provisions of the building code. It is not a consent under the Resource Management Act and does not affect any duty or responsibility under any other Act nor permit any breach of any other Act.

This building consent is issued subject to the conditions specified in the attached page(s) headed CONDITIONS OF BUILDING CONSENT 961906. It is your responsibility to ensure all conditions are complied with. The building consent does not guarantee or imply continuous supervision by Council.

SIGNED FOR AND ON BEHALF OF THE COUNCIL:

Position:

Date:

Main Office

189 Queen Street
Private Bag 4,
Richmond 7031 N.Z.
Tel (03) 544-8176
Fax (03) 544-7249

Murchison Service Centre

92 Fairfax Street
P.O. Box 53, Murchison
Tel (03) 523-9004
Fax (03) 523-9004

Motueka Service Centre

7 Hickmott Place
P.O. Box 123, Motueka
Tel (03) 528-7700
Fax (03) 528-9751

Golden Bay Service Centre

78 Commercial Street
P.O. Box 74, Takaka
Tel (03) 525-9516
Fax (03) 525-9972

CONDITIONS OF BUILDING CONSENT 961906

- 1 SPECIAL CONDITION: Finished floor height to be as NZS 3604 .225 to ground level or .150 to permanent paving.
- 2 Owner to ensure existing septic tank & disposal system is examined by Councils' Drainage Inspector to approve its future use, existing discharge system for grey water to be located.
- 3 Re design siting of well liners for stormwater discharge to a position away from the area where the septic tank is sited.
- 4 New septic tank system to be installed as discussed with owner.
- 5 The building inspector is to be notified at least one working day prior to the pouring of concrete on site or the laying of flooring.
- 6 The owner or person undertaking the building work shall give at least one working days notice before placing any insulation and interior linings to enable a "pre-lining" inspection.
- 7 Construction and wall bracing to comply with NZS3604.
- 8 All glass to comply with NZS 4223.
- 9 The owner and the Builder are responsible for the correct siting of the Building work as specified on the approved plans.
- 10 The owner or person undertaking the building work shall give at least one working day's notice to cover up or close in of any Drainage system.
- 11 The owner or person undertaking the building work shall give at least two working day's notice to cover up or close in of any Plumbing work.
- 12 Installation of Plumbing and Drainage for new dwelling to comply to the Building Code and connection to septic tank/effluent disposal system as approved by an Enforcement Officer.

□ **Main Office**
189 Queen Street
Private Bag 4,
Richmond 7031 N.Z.
Tel (03) 544-8176
Fax (03) 544-7249

□ **Murchison
Service Centre**
92 Fairfax Street
P.O. Box 53, Murchison
Tel (03) 523-9004
Fax (03) 523-9004

□ **Motueka
Service Centre**
7 Hickmott Place
P.O. Box 123, Motueka
Tel (03) 528-7700
Fax (03) 528-9751

□ **Golden Bay
Service Centre**
78 Commercial Street
P.O. Box 74, Takaka
Tel (03) 525-9516
Fax (03) 525-9972

BUILDING CONSENT 961906 [Continued]

- 13 No Plumbing and Drainage work is to commence prior to the council receiving names of your nominated Plumber or Drainlayer. The attached advisory sheets are to be completed and returned to this office for our records.
- 14 The owner or person undertaking the building work shall advise of completion of work by returning the "Advice of Completion of Building Work" form which accompanied the consent.
- 15 A copy of this consent is to remain on site at all times and you should ensure that a copy is given to any tradesmen e.g. your builder, plumber and drainlayer..
- 16 All Building Work shall comply with the New Zealand Building Code notwithstanding any inconsistencies which may occur on the Drawings and Specifications.
- 17 This consent will expire if building work is not commenced within 6 months from the date of issue unless a written extension of time is obtained from the Building Inspector.

□ **Main Office**
189 Queen Street
Private Bag 4,
Richmond 7031 N.Z.
Tel (03) 544-8176
Fax (03) 544-7249

□ **Murchison
Service Centre**
92 Fairfax Street
P.O. Box 53, Murchison
Tel (03) 523-9004
Fax (03) 523-9004

□ **Motueka
Service Centre**
7 Hickmott Place
P.O. Box 123, Motueka
Tel (03) 528-7700
Fax (03) 528-9751

□ **Golden Bay
Service Centre**
78 Commercial Street
P.O. Box 74, Takaka
Tel (03) 525-9516
Fax (03) 525-9972



tasman

district council
938093400
BC091328

Writer's Direct Dial No. (03) 543 8523
Writer's E-mail: gary.tipler@tasman.govt.nz

16th March 2010

B Ivory
117 Barnett Avenue
RD 1
Richmond 7081

FILE

Dear Sir/Madam

**CONFIRMATION OF APPLICATION RETURN
PIM/Building Consent no. BC091328
117 Barnett Avenue, Best Island
Alterations to dwelling: Construct studio at northern end of house**

Further to our correspondence of 15/12/09, 11/02/10, and 01/03/10.

This letter is to confirm to you the return of the above PIM/Building Consent application. Please find enclosed plans and specifications provided in support of the PIM/Building Consent application.

Please note that the deposit fee paid at the time of lodgement of your application is non-refundable, as it covers the administration and processing costs up to invoicing stage.

A new application and approval, including fees, relevant plans and specifications will be required should the project be again considered at some future date.

Should you have any queries, please contact me.

Yours faithfully

Gary L Tipler
Co-ordinator, Building Control

TO: Building Administration / File

FROM: Gary Tipler

DATE: 16 March 2010

FILE NO: BC 091328 - 117 Barnett Avenue

RE: Return of building consent application

The requests for information, 15 December 2009, 11 February 2010 and 1 March 2010, have not met with any response from the applicant or owner. There has also been an additional elapsed time period opportunity (1 March - 16 March)

Further to the application process detailed in these letters, consideration has now been given, and the decision made to return the application.

Please undertake one final check for receipt of the requested information, and then ensure that any Tasman District Council Building Consent Authority stamps, workings or markings are removed from the documents prior to the return of the application and the covering letter confirming the application return.



Gary L Tipler
Co-Ordinator Building Control

MAIN BUILDING - R1 - SOLID FUEL BURNING APPLIANCE ONLY - Processing - AUDIT				
Y/N	User	Date	Notes	
HEATING APPLIANCES				
Solid Fuel Burner				
Heater - BC Complexity / Competence (Reg 10 & 18 of BCA Regs 2006): Has the correct building complexity been allocated to this project and is it within the scope of your assessed competence? Do not select X or N/A. If complexity is incorrect please rectify by selecting the correct checklist (under Manage Buildings). If processing of this project is to be undertaken under supervision then ensure that this is recorded here.				
Y	SK	13/06/2019 08:32 am	Complexity is correctly assigned. I have the appropriate level of competence	
Heater - F5: Construction and Demolition Hazards: Does the proposal confirm that provisions will be initiated on site to safeguard people from injury and other property from damage caused by construction activity? Selecting the Tick will apply Advice Note AN01 which advises the owner of their on-site obligations under F5.				
Y	SK	13/06/2019 08:32 am	Advice Note AN01 - Site Safety has been applied. This advises the building consent applicant of their obligation to comply with F5 and Worksafe requirements.	
Heater - Act Provisions: Are all Building Act legislative requirements satisfied?				
Y	SK	13/06/2019 08:32 am		
Heater - Act Provisions - Prompt List:				
Y	SK	13/06/2019 08:32 am	1. s26 -28: Does the work exclude use of a building method or product that may result in breach of a ban under BA 26?	
Y	SK	13/06/2019 08:32 am	2. s112: If the proposal involves alteration to an existing building, does it demonstrate on reasonable grounds that after alteration the building will:(a) Comply, as nearly as reasonably practicable, with provisions that relate to means of escape from fire, and access & facilities for people with disabilities (if required by Section 118), and(b) Continue to comply with the other provisions of the building code to at least the same extent as before alteration?	
Domestic Solid Fuelburning Appliances: Does the design demonstrate compliance with C/VM1 or C/AS1 and comply with AS/NZS 2918 as modified by Para 7.1.2 of the relevant Fire Code Acceptable Solution for the risk group in which the appliance is to be installed? If this application is for a free standing fire then please turn off the Chimney - Inbuilt Inspection before granting building consent.				
Domestic Solid Fuelburning Appliances - Prompt List:				
N/A	SK	13/06/2019 08:34 am	1. In-built Appliance: If the appliance / flue system is being installed within an existing fire place or chimney; then is confirmation provided that this is clean, structurally sound and satisfies building code provisions for B1 - Structure and B2 - Durability? Select N/A if this application for a free standing appliance or an inbuilt heater that is not being installed in an existing chimney..	
Y	SK	13/06/2019 08:34 am	2. Location: Does documentation show the proposed location of the appliance? Information should include scale floor plan with rooms labelled and show the location of appliance in relation to windows, doors, curtains and walls etc.	
Y	SK	13/06/2019 08:34 am	3. Documentation: Do plans, specifications and installation instructions demonstrate compliance with C2.1 and AS/NZS 2918 as modified by Para 7.1.2? Information should include: appliance testing and approval details, specific installation information including permitted clearances to heat sensitive materials, floor protector (hearth) installation and seismic restraint details, flue installation details identifying location/ height / bracing above roof level, flue penetration details through walls / ceilings/ floors / roofs etc.	
Y	SK	13/06/2019 08:34 am	4. Structure (B1 & B2): Do details demonstrate that structural stability will not be compromised where flues penetrate structural elements (walls / ceilings / roofs etc), and confirm compliance with B2 - Durability and identify maintenance requirements?	
5. External Moisture (E2): Do building envelope penetration flashing details demonstrate compliance with AS/NZS 2918 & E2?				
6. Ventilation (G4): Do ventilation details demonstrate compliance with G4/AS1 (this includes ventilation to false chimneys)?				
7. Emissions: Is confirmation is provided that the system satisfies National / Regional Emission Standards?				

MAIN BUILDING - R1 - SOLID FUEL BURNING APPLIANCE ONLY - Processing - AUDIT	Y/N	User	Date	Notes
8. Smoke Detectors (C): Has the designer specified a complying Type 1 smoke alarm system and correctly identified the location of the smoke detectors?				
Domestic Solid Fuelburning Appliances - Prompt List:		SK	13/06/2019 08:47 am	
1. In-built Appliance: If the appliance / flue system is being installed within an existing fire place or chimney; then is confirmation provided that this is clean, structurally sound and satisfies building code provisions for B1 - Structure and B2 - Durability? Select N/A if this application for a free standing appliance or an inbuilt heater that is not being installed in an existing chimney..	N/A	SK	13/06/2019 08:47 am	This question does not apply to this Project.
2. Location: Does documentation show the proposed location of the appliance? Information should include scale floor plan with rooms labelled and show the location of appliance in relation to windows, doors, curtains and walls etc.	Y	SK	13/06/2019 08:47 am	Documentation shows the proposed location of the appliance - lounge on floor plan.
3. Documentation: Do plans, specifications and installation instructions demonstrate compliance with C2.1 and AS/NZS 2918 as modified by Para 7.1.2? Information should include: appliance testing and approval details, specific installation information including permitted clearances to heat sensitive materials, floor protector (hearth) installation and seismic restraint details, flue installation details identifying location/ height / bracing above roof level, flue penetration details through walls / ceilings/ floors / roofs etc.	Y	SK	13/06/2019 08:47 am	Plans, specifications and installation instructions demonstrate compliance C2.1, and with AS/ NZS 2918 as modified by Para 7.1.2. Metro R2 (tested) - specs provided - NZS2918 (clearances / distances). Flu spec included - SFP freestanding 150mm flue kit. Flue penetration / plate flashing. Type 1 smoke alarms detailed on plans - F7/AS1.
4. Structure (B1 & B2): Do details demonstrate that structural stability will not be compromised where flues penetrate structural elements (walls / ceilings / roofs etc), and confirm compliance with B2 - Durability and identify maintenance requirements?	Y	SK	13/06/2019 08:47 am	Complying details are provided and demonstrate that structural stability will not be compromised where flues penetrate walls / ceilings / roofs / insulation etc. Confirmation of compliance with B2 - Durability and maintenance requirements is provided.
5. External Moisture (E2): Do building envelope penetration flashing details demonstrate compliance with AS/NZS 2918 & E2?	Y	SK	13/06/2019 08:47 am	Compliance with E2 is satisfied. Chimney plate / flue flashing roof detailing provided.
6. Ventilation (G4): Do ventilation details demonstrate compliance with G4/AS1 (this includes ventilation to false chimneys)?	Y	SK	13/06/2019 08:47 am	Ventilation: Details demonstrate compliance with G4/AS1 - Existing natural ventilation provided for previous space - no worse than before.
7. Emissions: Is confirmation is provided that the system satisfies National / Regional Emission Standards?	Y	SK	13/06/2019 08:47 am	Emissions: Information provided confirms that the system satisfies National / Regional Emission Standards. Checked NCC clean air list - number
8. Smoke Detectors (C): Has the designer specified a complying Type 1 smoke alarm system and correctly identified the location of the smoke detectors?				
Domestic Solid Fuelburning Appliances - Prompt List:	Y	SK	13/06/2019 09:05 am	
1. In-built Appliance: If the appliance / flue system is being installed within an existing fire place or chimney; then is confirmation provided that this is clean, structurally sound and satisfies building code provisions for B1 - Structure and B2 - Durability? Select N/A if this application for a free standing appliance or an inbuilt heater that is not being installed in an existing chimney..	N/A	SK	13/06/2019 09:05 am	This question does not apply to this Project.
2. Location: Does documentation show the proposed location of the appliance? Information should include scale floor plan with rooms labelled and show the location of appliance in relation to windows, doors, curtains and walls etc.	Y	SK	13/06/2019 09:05 am	Documentation shows the proposed location of the appliance - lounge on floor plan.
3. Documentation: Do plans, specifications and installation instructions demonstrate compliance with C2.1 and AS/NZS 2918 as modified by Para 7.1.2? Information should include: appliance testing and approval details, specific installation information including permitted clearances to heat sensitive materials, floor protector (hearth) installation and seismic restraint details, flue installation details identifying location/ height / bracing above roof level, flue penetration details through walls / ceilings/ floors / roofs etc.	Y	SK	13/06/2019 09:05 am	Plans, specifications and installation instructions demonstrate compliance C2.1, and with AS/ NZS 2918 as modified by Para 7.1.2. Metro R2 (tested) - specs provided - NZS2918 (clearances / distances). Flu spec included - SFP freestanding 150mm flue kit. Flue penetration / plate flashing. Type 1 smoke alarms detailed on plans - F7/AS1.
4. Structure (B1 & B2): Do details demonstrate that structural stability will not be compromised where flues penetrate structural elements (walls / ceilings / roofs etc), and confirm compliance with B2 - Durability and identify maintenance requirements?	Y	SK	13/06/2019 09:05 am	Complying details are provided and demonstrate that structural stability will not be compromised where flues penetrate walls / ceilings / roofs / insulation etc. Confirmation of compliance with B2 - Durability and maintenance requirements is provided.
5. External Moisture (E2): Do building envelope penetration flashing details demonstrate compliance with AS/NZS 2918 & E2?	Y	SK	13/06/2019 09:05 am	Compliance with E2 is satisfied. Chimney plate / flue flashing roof detailing provided.

MAIN BUILDING - R1 - SOLID FUEL BURNING APPLIANCE ONLY - Processing - AUDIT	Y/N	User	Date	Notes
6. Ventilation (G4): Do ventilation details demonstrate compliance with G4/AS1 (this includes ventilation to false chimneys)?	Y	SK	13/06/2019 09:05 am	Ventilation: Details demonstrate compliance with G4/AS1 - Existing natural ventilation provided for previous space - no worse than before.
7. Emissions: Is confirmation is provided that the system satisfies National / Regional Emission Standards?	Y	SK	13/06/2019 09:05 am	Emissions: Information provided confirms that the system satisfies National / Regional Emission Standards. Checked NCC clean air list - number 134104
8. Smoke Detectors (C): Has the designer specified a complying Type 1 smoke alarm system and correctly identified the location of the smoke detectors?	Y	SK	13/06/2019 09:05 am	Smoke detectors are correctly located. Position of smoke detectors are within three metres of the door to all sleeping areas-dead end path is less than 25m SORG's
Solid Fuel Burner - G12: Wet back / Water Booster: Does the proposal for the installation of the wet back / water booster system demonstrate compliance with G12 & H1.2b)?				
Solid Fuel Burner - G12: Wet back / Water Booster - Prompt List:	N/A	SK	13/06/2019 09:06 am	This question does not apply to this application.
1. Design: Does the plumbing design / schematic demonstrate compliance with provisions of G12 & H1?				
2. Specification: Is the system correctly specified and identify - complying materials, open vented cylinder, copper pipework, that the storage vessel is of appropriate size, pipe work is correctly sized, length of runs comply, provision for expansion to non-vented systems without discharge of hot water, insulation of pipe runs, support for the system and seismic restraint?				
3. Venting: Is venting compliant?				
4. Temperature Control: Is temperature control compliant and identify that it is adequate to avoid growth of legionella bacteria & to avoid scalding?				
5. Drainage & Pressure Relief: Is a compliant solution provided for drainage and pressure relief?				
6. B2: Is compliance with durability provisions demonstrated and is complying access available to enable service and maintenance?				
7. Protection: Is the provision for protection of the water supply compliant?				
8. H1 - Energy: Does the design facilitate the efficient use of hot water, and limit heat loss?				
Solid Fuel Burning Appliance - Miscellaneous: Please select the cross if you wish to raise an RFI for an item that may not clearly fit into any other category.	Y	SK	13/06/2019 09:06 am	(No Comments)

Processing Time Clock Start Date: 24/05/2019 02:52 am

Decision To Grant: BC190638 by Shane Kelly @ 13/06/2019 09:40 am

Project ID: 190638

Date Sent: 2019-07-01 15:32:28

Recipient:

jacqui.soffer@therentshop.co.nz, office@pmfireplaces.co.nz

Sender: Julian Malcolm

Subject:

BC190638.1 Form 7: Code Compliance Certificate - 117 Barnett Avenue, Best Island

Message:

Dear Sir/Madam,

Please find attached a copy of your code compliance certificate for BC190638.

If you have any questions please contact Tasman District Council on 03 543 8400.

Regards

Julian Malcolm

Building Technical Officer

Tasman District Council

189 Queen Street, Richmond 7020

P: 03 543 8400 | E: bc.admin@tasman.govt.nz | W: <http://www.tasman.govt.nz>

MAIN BUILDING - R1 - SOLID FUEL BURNING APPLIANCE ONLY - Inspections - AUDIT				
	Pass	User	Date	Notes
Final				
Heater - BC Complexity / Competence (Reg 10 & 18 of BCA Regs 2006): Is inspection of this project within the scope of your assessed competence? Do not select X or N/A. If you are inspecting this project under supervision please ensure that this is recorded here.	Pass	JMm	01/07/2019 09:00 am	Complexity is correctly assigned. I have the appropriate level of competence OR I am undertaking this under supervision - my supervisor is ..
	Pass	JMm	01/07/2019 09:01 am	Complexity is correctly assigned. I have the appropriate level of competence
Heater - F5: Construction and Demolition Hazards: Is site safety properly managed with work-site hazards identified and mitigated?	Pass	JMm	01/07/2019 09:01 am	No obvious work site hazards were observed during the course of this inspection.
Heater - Act Provisions: Are all Building Act legislative requirements satisfied? Heater - Act Provisions - Prompt List:	<u>Pass</u>	<u>JMm</u>	<u>01/07/2019 09:02 am</u>	
1. s26 - 28: In terms of section 28 of the Building Act, can the building consent authority exercise its powers to issue building consent and code compliance certificate for the building work relating to this building consent? DO NOT select N/A for this question.	PASS	JMm	01/07/2019 09:01 am	No warning or bans issued.
2. s37: Have all resource consent conditions been satisfied? select N/A if there are no conditions	N/A	JMm	01/07/2019 09:02 am	This question does not apply to this consent.
3. s92: Has a correctly completed Application for Code Compliance Certificate been received?	PASS	JMm	01/07/2019 09:02 am	Application for CCC received.
Domestic Solid Fuelburning Appliances: Is the completed installation of the solid fuel burning appliance in accordance with the building consent? Domestic Solid Fuelburning Appliances - Prompt List:	<u>Pass</u>	<u>JMm</u>	<u>01/07/2019 09:14 am</u>	
1. Type / Location: Is the appliance type, installation and location compliant?	PASS	JMm	01/07/2019 09:17 am	Appliance type METRO R2/ location and installation is compliant.
2. Floor Protector: Is installation compliant?	PASS	JMm	01/07/2019 09:04 am	Floor protector installation is compliant. Existing Fire hearth. Built up, concrete base on wooden floor
3. Flue Assembly: Is this compliant? (Check - fixings, clearances from combustible surfaces and insulation and building wrap, support, bracing, height and location above roof level)	PASS	JMm	01/07/2019 09:06 am	Flue assembly, fixing, clearances, support and height are compliant.
4. Means of Escape: Is this compliant? (Check - travel distances, free from obstructions)	PASS	JMm	01/07/2019 09:06 am	Means of escape complies with building consent.
5. E2: Are penetrations through the building envelope correctly flashed and compliant?	PASS	JMm	01/07/2019 09:07 am	Penetrations through the building envelope are correctly flashed and compliant
6. F7: Is the location & type of smoke detectors compliant?	PASS	JMm	01/07/2019 09:14 am	The location and type of smoke detectors is compliant. 6 working smoke alarms. new batteries confirmed by tenant on site
7. G4: Does ventilation comply with the building consent?	PASS	JMm	01/07/2019 09:14 am	Ventilation is compliant
8. Records: Has the appliance serial number been recorded?	N/A	JMm	01/07/2019 09:14 am	Not able to record serial number
9. B2: Have durability requirements been satisfied?	PASS	JMm	01/07/2019 09:14 am	Durability provisions satisfied.
10. Installer/ Required Documents: Has the installer qualifications and details been recorded and has the required quality assurance documentation been obtained.	PASS	JMm	01/07/2019 09:14 am	Installer details and quality assurance documentation has been provided. P&M fire installers
Domestic Solid Fuelburning Appliances: Is the completed installation of the solid fuel burning appliance in accordance with the building consent? Domestic Solid Fuelburning Appliances - Prompt List:	<u>Pass</u>	<u>JMm</u>	<u>01/07/2019 02:58 pm</u>	
1. Type / Location: Is the appliance type, installation and location compliant?	PASS	JMm	01/07/2019 02:58 pm	Appliance type METRO R2/ location and installation is compliant.
2. Floor Protector: Is installation compliant?				
3. Flue Assembly: Is this compliant? (Check - fixings, clearances from combustible surfaces and insulation and building wrap, support, bracing, height and location above roof level)				

MAIN BUILDING - R1 - SOLID FUEL BURNING APPLIANCE ONLY - Inspections - AUDIT	Pass	User	Date	Notes
4. Means of Escape: Is this compliant? (Check - travel distances, free from obstructions)				
5. E2: Are penetrations through the building envelope correctly flashed and compliant?				
6. F7: Is the location & type of smoke detectors compliant?				
7. G4: Does ventilation comply with the building consent?				
8. Records: Has the appliance serial number been recorded?				
9. B2: Have durability requirements been satisfied?				
10. Installer/ Required Documents: Has the installer qualifications and details been recorded and has the required quality assurance documentation been obtained.				

Decision To Issue CCC: Julian Malcolm at 01/07/2019 03:31 pm

01 July 2019

Kursten Dion Ward and Elke Baumann-ward
117 Barnett Avenue
RD 1
Richmond 7081

Dear Kursten Dion Ward and Elke Baumann-ward

Site Inspection Report

Reference: BC190638

Location: 117 Barnett Avenue, Best Island, Lot 3 DP 533749

Project: Install freestanding Metro wood burner

IR Number: 1

Inspection Results:

FINAL - 01 Jul 2019 @ 14:59 by Julian Malcolm

Inspection Outcome: **PASS** - The BCA is satisfied, on reasonable grounds, that the aspects of building work pertaining to this inspection demonstrate compliance with the building consent.

Inspection Summary: Final CCC inspection for free standing fire and smoke alarms. New Fire type METRO R2 Installed as per the stamped consented plans and specifications. Complies AS/NZS 2918-2018, and F7. Pass, CCC can be issued.

Your next inspection will be: **No further inspection required**

Outstanding Required Documents for this Building

History

Inspection Name

Final

Summary

PASS - 01 Jul 2019

Please plan your project ahead of time and allow a minimum of 2 working days' notice when booking all inspections.

Yours sincerely

Julian Malcolm

Building Technical Officer

On behalf of **Tasman District Council**





-BC100633

Page 11 of 17



-BC190638

Page 5 of 7





BC190638

Page 7 of 7



Sheetmetal Fabricated Products Ltd.

150 MM FREE STANDING WOODFIRE FLUE KIT INSTALLATION INSTRUCTIONS

WARNING: THIS FLUE KIT HAS BEEN MANUFACTURED IN ACCORDANCE WITH AS/NZS 2918:2001 AND TESTED TO APPENDIX F. TO ENSURE SAFETY THIS FLUE KIT MUST BE INSTALLED AS OUTLINED IN THESE INSTRUCTIONS AND THE APPROPRIATE REQUIREMENTS OF THE RELEVANT BUILDING CODE OR CODES. WOOD FIRE AND FLUE CLEARANCES FROM COMBUSTIBLE WALLS MUST BE IN ACCORDANCE WITH WOOD FIRE MANUFACTURER'S SPECIFICATIONS AND AS/NZS 2918:2001. THESE INSTALLATION INSTRUCTIONS ARE FOR TESTED APPLIANCES ONLY.

CAUTION: MIXING FLUE SYSTEM COMPONENTS FROM DIFFERENT SOURCES OR MODIFYING THE DIMENSIONAL SPECIFICATION OF COMPONENTS MAY RESULT IN HAZARDOUS CONDITIONS. WHERE SUCH ACTION IS CONSIDERED, THE MANUFACTURER SHOULD BE CONSULTED IN THE FIRST INSTANCE.

CAUTION: IT IS THE RESPONSIBILITY OF THE INSTALLER TO ENSURE THAT THE INSTALLATION OF THIS FLUE KIT COMPLIES WITH AS/NZS 2918:2001, THE APPLIANCE MANUFACTURERS SPECIFICATIONS FOR FLUE PIPE SHIELD AND CEILING PLATE AND THAT THE RELEVANT BUILDING CODES ARE ADHERED TO.

BENDS AND EXTENSIONS TO THE LENGTH OF A FLUE SYSTEM ARE PERMITTED (AS/NZS 2918 2001 4.1)

- 1) Locate Wood Fire in its proposed position and mark a point on the ceiling that is directly above the centre of the Wood Fire's Flue Spigot. Check that the Wood Fire's location allows the OUTER CASING to clear all structural roof timbers.
- 2) Cut a 250mm square hole in ceiling. Directly above cut a hole in roof to accommodate OUTER CASING.
- 3) Fit timber nogs around ceiling. i.e. Nogs form a 250mm square aperture that allows air to circulate freely over the OUTER CASING surface.
- 4) Position the OUTER CASING so that it is flush with the underneath of the ceiling and protrudes through the roof the required height. Note that AS/NZS 2918:2001 4.9.1(a) states, "the FLUE PIPE shall extend not less than 4.6m above the top of the floor protector". Refer to diagram B.
 - a) If the FLUE PIPE is within 3 metres of the ridge, the FLUE PIPE must protrude at least 600mm above the ridge of the roof.
 - b) If the distance from the ridge is more than 3 metres, the FLUE PIPE must protrude at least 1000mm above roof penetration.
 - c) The FLUE PIPE must be more than 3 metres from any nearby structure. (Refer diagram C).

Additional FLUE PIPE, OUTER CASING and/or INNER CASING may have to be added to ensure the following:

- I) The correct minimum roof penetration height.
- II) Sufficient overall height to encase the FLUE PIPE which must extend a minimum of 4.6 metres from the floor protector. Refer diagram B.

Note that the INNER CASING should extend 200mm above roof penetration.

NB: Do not secure the OUTER CASING SLIP EXTENSION onto the OUTER CASING, as final adjustment will be required when fitting cowl assembly. See Paragraph 11.

- 5) Fix an appropriate flashing around the OUTER CASING to seal onto the roofing material. Refer to the manufacturer's recommendations for correct fitting. NB: On iron roofs, fixings such as metal angle brackets (approximately 25mm x 25mm) can be fitted under the flashing to securely fix the roof to OUTER CASING.
- 6) Drill holes in ceiling plate for the fixing screws. Place CEILING PLATE over Wood Fire's Flue Spigot, ensuring the folded edges are facing the ceiling.
- 7) Position bottom length of FLUE PIPE (crimped end downwards) into Wood Fire Flue Spigot.

Refer to the supplier of the Wood Fire and use flue pipe sealant if recommended.

- 8) Assemble FLUE PIPES together ensuring seams are straight, offsetting the seams will ensure a neat fit. FLUE PIPES **must** be assembled with crimped ends down (towards Wood Fire). Secure each joint with a minimum of three Monel Steel rivets equally spaced around the joint. If using HI-THERM FLUE PIPE the protective wrapping should be left on the FLUE PIPE during installation.
- 9) From the roof lower FLUE PIPE through OUTER CASING into the bottom FLUE PIPE securing with three monel rivets.
- 10) Check that the FLUE PIPE SPACING BRACKETS inside the INNER CASING are correctly positioned and then from the roof slide the INNER CASING into the OUTER CASING until the brackets rest on to the internal swage ring of the OUTER CASING, this will ensure the INNER CASING is the correct 12mm above ceiling level.

Check the INNER CASING when correctly positioned extends a minimum of 200mm above the roof penetration.

- 11) Before securing the OUTER CASING SLIP EXTENSION to the OUTER CASING with 3 rivets, ensure the FLUE PIPE extends above the top of the OUTER CASING SLIP EXTENSION 145mm. Adjust SLIP EXTENSION to obtain this measurement.
- 12) Fit TOP SPACER BRACKET to the FLUE PIPE making sure the lugs fit snugly inside OUTER CASING SLIP EXTENSION. Make sure TOP SPACER BRACKET fits hard down onto OUTER CASING SLIP EXTENSION.
- 13) Fit CASING COVER over the FLUE PIPE and push down firmly onto TOP SPACER BRACKET.
- 14) Fit COWL but do not secure, as removal for flue cleaning will be necessary. Deform or ovalise the stub of the COWL to ensure it is a tight friction fit.
- 15) Fasten CEILING PLATE to ceiling using screws and ceramic spacers provided. Ensure an even air gap around FLUE PIPE when fixing. Remove protective plastic from CEILING PLATE. N.B. 12mm air gap between ceiling plate and ceiling must be maintained.
- 16) Leave all installation and operating instructions with the owner.

Cleaning of Flue Pipes before lighting the fire.

Stainless Steel pipe should be wiped clean using a soft cloth and methylated spirits to remove finger marks and oils used to manufacture the flue pipe.

Hi-Therm flue pipe can be touched up using only STOVE BRIGHT aerosol paint.



150mm Free Standing Wood Fire Flue Kit Installation Instructions Complies with AS/NZS 2918:2001

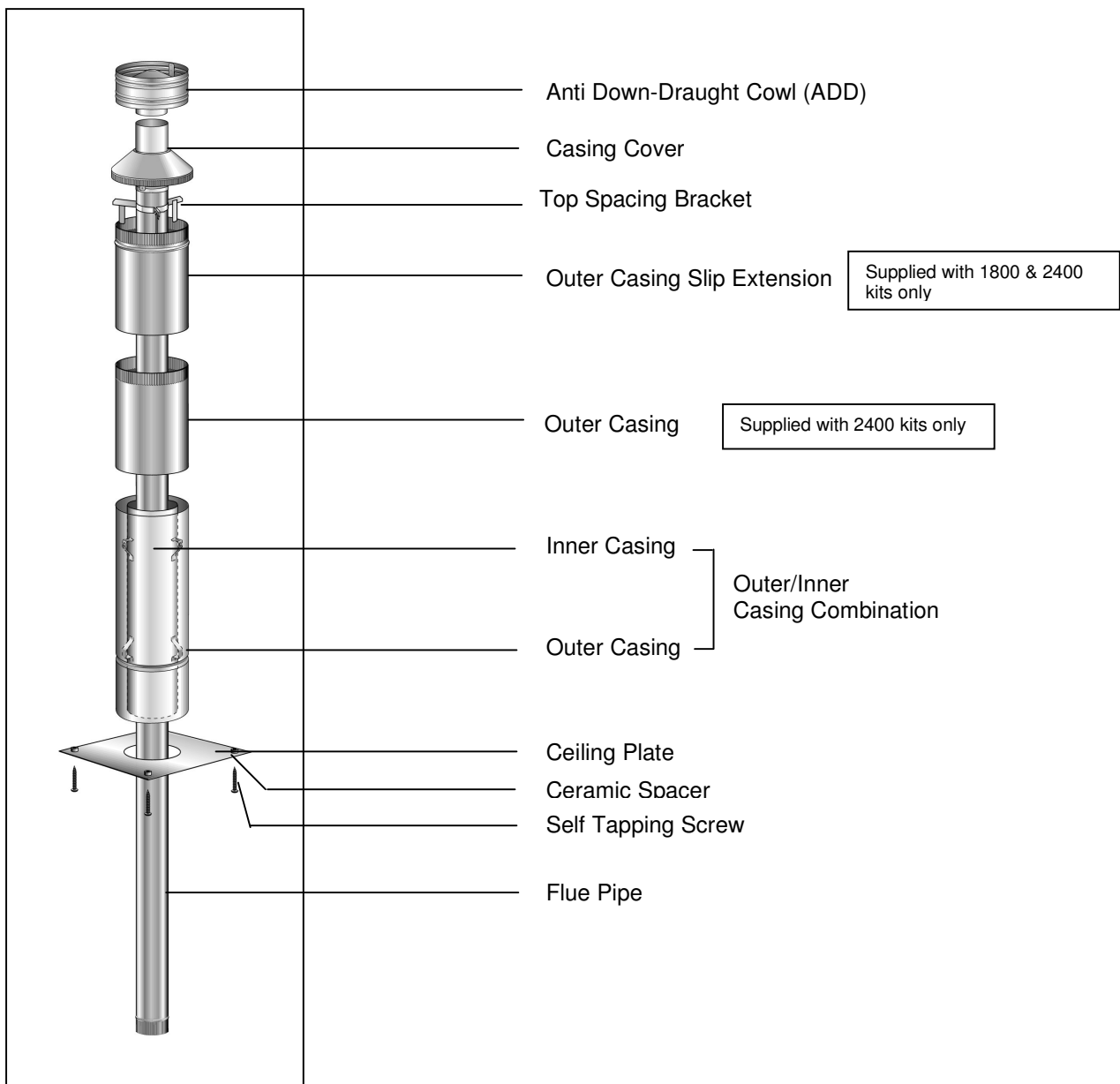

Diagram C AS/NZS 2918:2001 pg 37

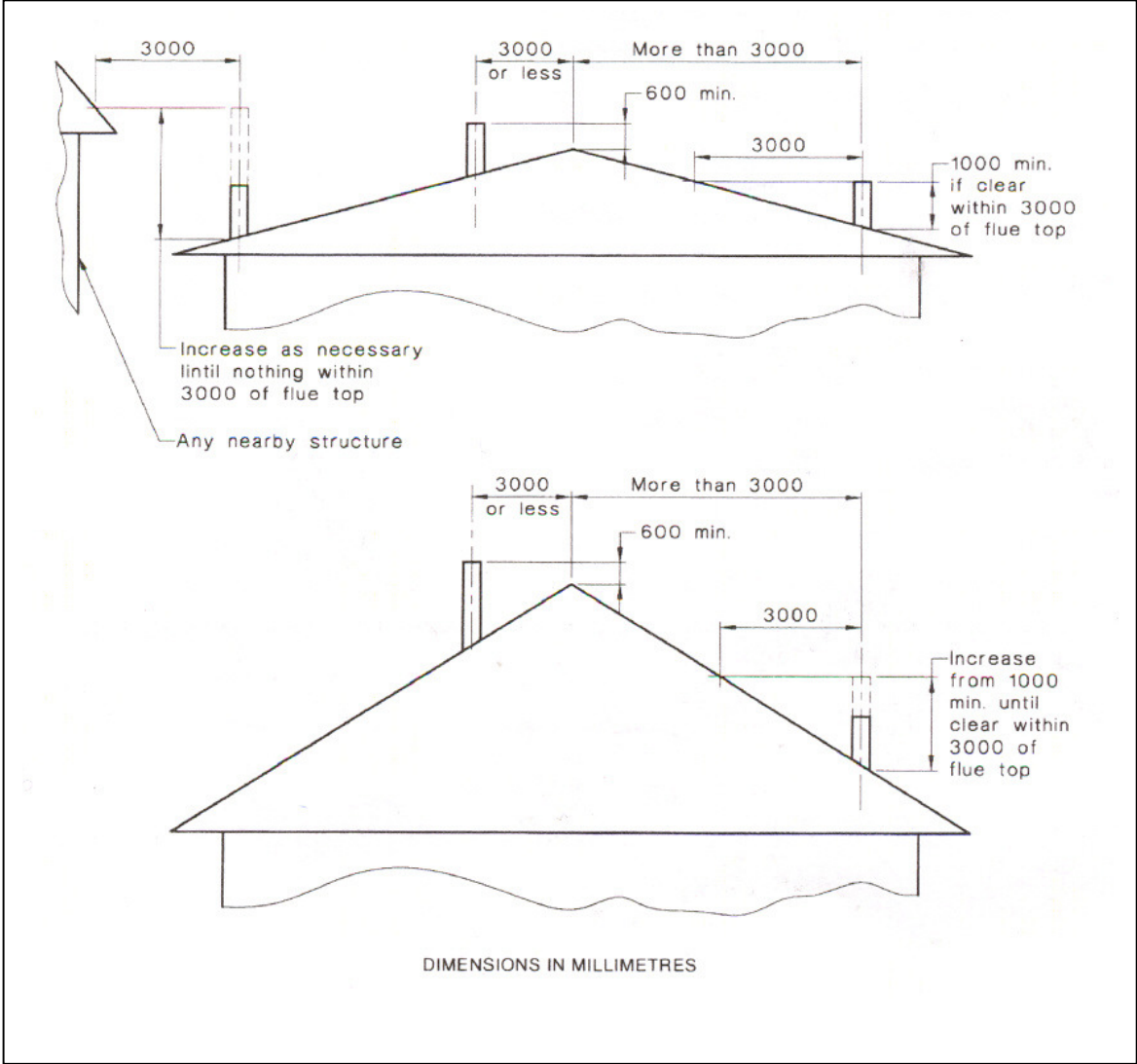
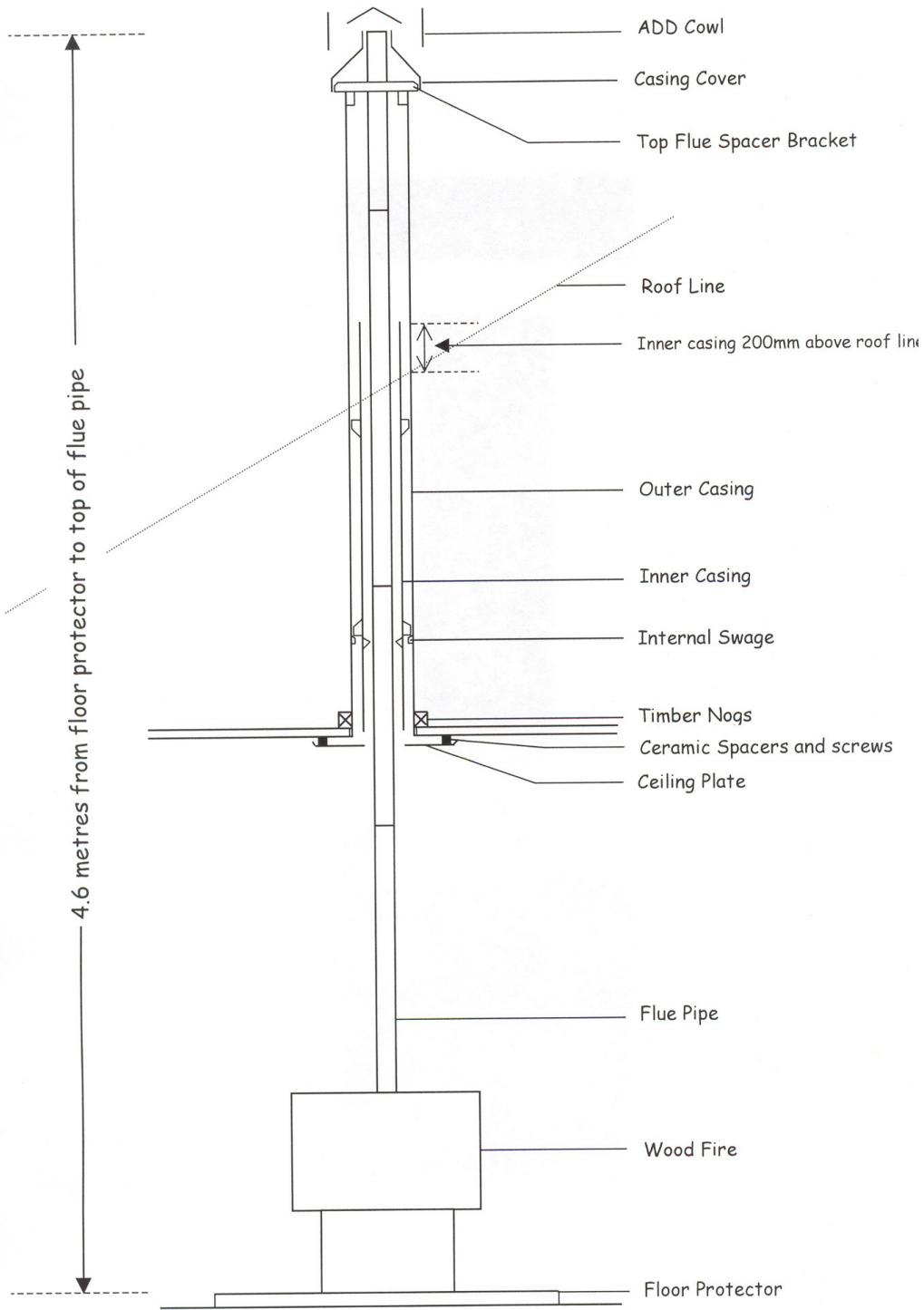

Diagram B



HI-THERM STAINLESS STEEL FLUE PIPES

HI-THERM Flue Pipe is a high temperature, matt finish Flue Pipe designed for use on slow combustion, solid fuel heaters.

HI-THERM Flue Pipe is ideal for heaters that have high flue temperatures and that also can be operated under circumstances that may produce creosoting of Flue Pipes for short periods of time, ie, on refuelling and with air control in shut or low position. Clean air guidelines must be observed.

- HI-THERM Flue Pipe is a **maintainable** product.

CONDITIONS OF USE

- *The Wood Fire must be operated in accordance with the manufacturer's instructions. Clean air guidelines and regulations must be observed.*
- *HI-THERM Flue Pipe must be swept by mechanical means only. (We recommend mixed head or polypropylene brushes). Under NO circumstances should chemical flue cleaners, (soot destroyers) or steel chimney brushes be used.*
- *HI-THERM Flue Pipe should not be used on a Wood Fire burning treated or wet (unseasoned) wood. **Only use newspaper when lighting the fire; never burn colour printed brochures or junk mail.***
- *HI-THERM Flue Pipes **must** be secured together with a minimum of three Monel Steel rivets equally spaced around the joint.*
- *The paint finish appearance may change, depending on Wood Fire operation and is designed to be a MAINTAINABLE finish. To maintain paint finish or touch up use only genuine STOVE BRIGHT Aerosol. (Refer label on packaging).*
- *HI-THERM Flue Pipe must be installed in accordance with SFP installation instructions, using flue componentry supplied by SFP. It is the responsibility of the installer to ensure no water leaks into the Hi-Therm Flue System.*
- *The Stainless Steel Flue Pipe used in "Hi-Therm Stainless Steel Flue Pipe" is warrantied for five years, providing the above conditions are met.*

**FAILURE TO OBSERVE THESE CONDITIONS
MAY NEGATE WARRANTIES**

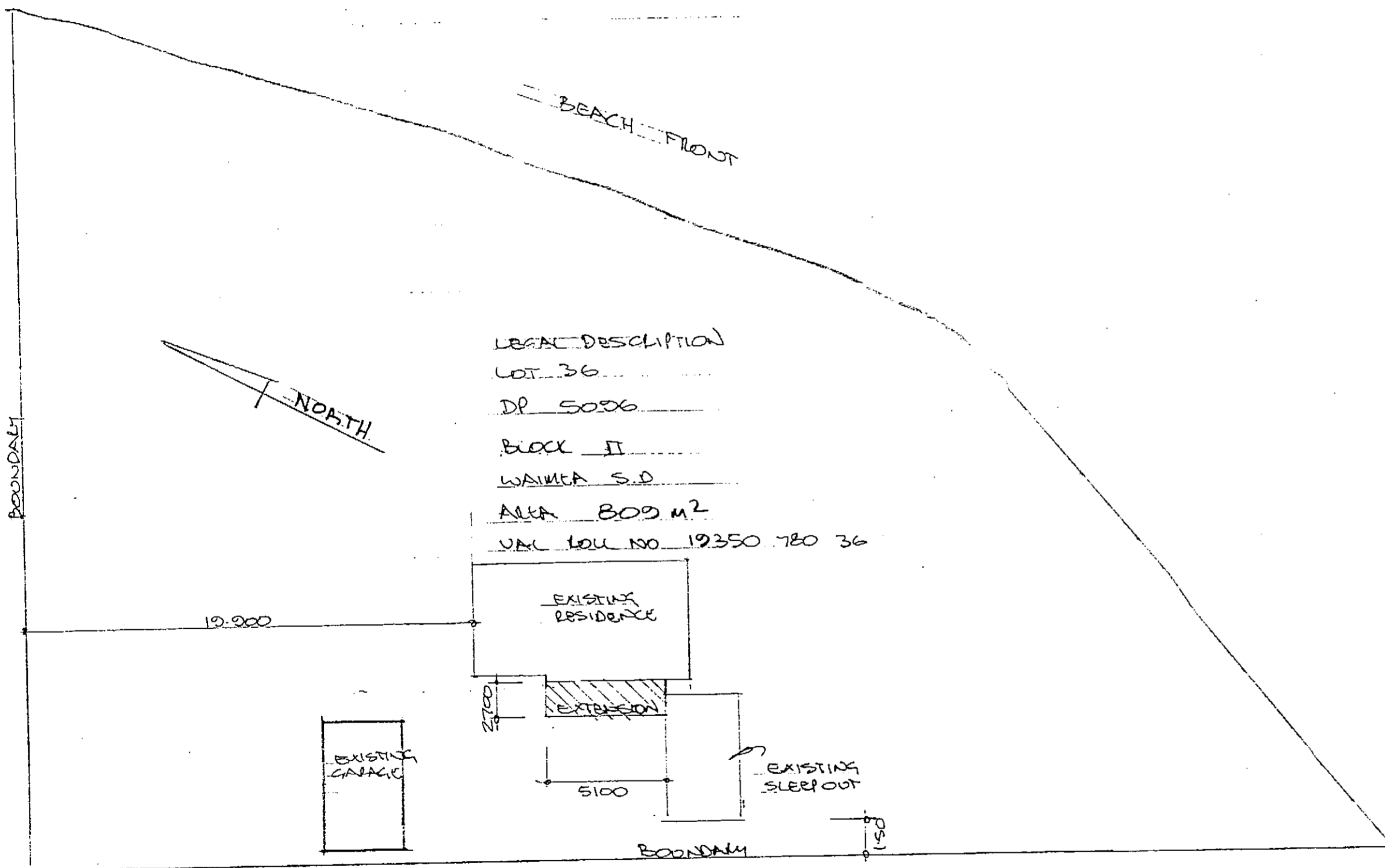

SITE PLAN 1:200

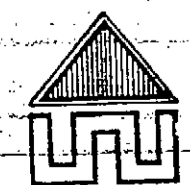

Allan Walters - draughtsman
 NZCD(arch), NZCQS, MNZID
 Phone (03) 541 8156 Wakefield

EXTENSION TO RESIDENCE
 AT BEST ISLAND
 FOR NICK HERRON

SCALE
 1:200

SITE PLAN

DRAWN WALTERS DEC 05

SHEET
 1
 960



FLOOR PLAN AS EXISTING 1:50

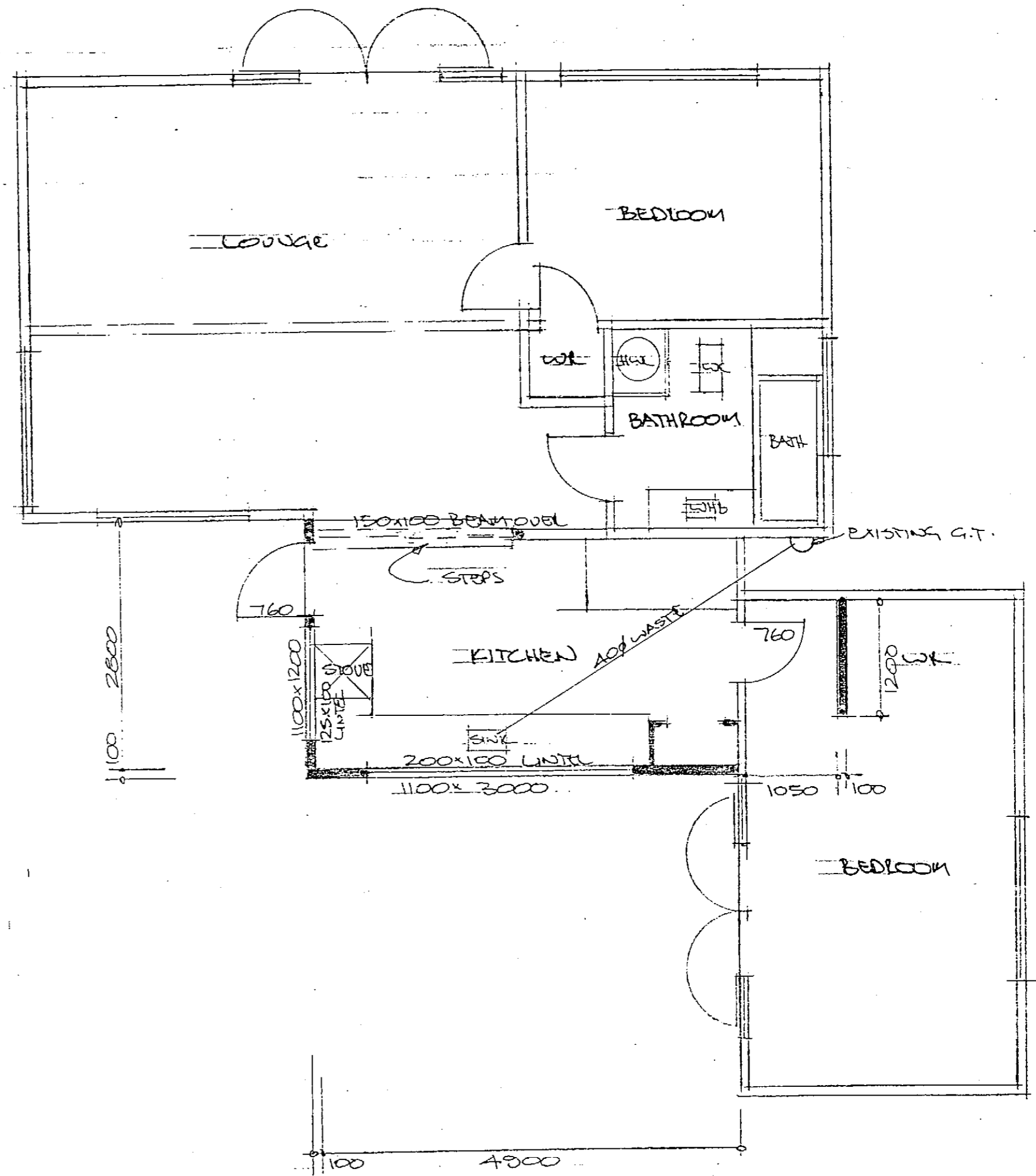

FLOOR PLAN AS ALTERED 1:50

LEGEND	
	EXISTING 100x50 TIMBER FRAMED WALLS
	NEW TIMBER FRAMED WALLS

TASMAN DISTRICT COUNCIL
APPROVED CONSENT DOCUMENT
 ● THIS DOCUMENT MUST STAY ON JOB UNTIL COMPLETION
 ● GIVE 24 HOURS NOTICE before any work is covered up.
 ● Council inspections are required BEFORE any
 - concrete, masonry infill, grouting, placement
 - lining, cladding, roof fixing
 - structural frame enclosure
 - trim fixing, lining stopping
 - plumbing, drainlaying, covering.
 ● Deviations from this Document requires further approval.
 ● Consent holder is responsible and liable for any damage as a result of this work being carried out.

TASMAN DISTRICT COUNCIL
 These are the specifications referred to in
 Building Consent No. _____
 Date _____ 19____
 BUILDING INSPECTOR

SPECIFICATION

EXTENSIONS TO HOUSE - BESTS ISLAND FOR MR C. & MRS L. HAWKINS.

Property owners have a legal obligation under the Plumbers Gasfitters and Drainlayers Act 1976 to have a craftsman plumber and registered drainlayer carry out their appropriate trade. Failure to do so could lead to legal action.

**TASMAN DISTRICT COUNCIL
APPROVED CONSENT DOCUMENT**

THIS DOCUMENT MUST STAY ON JOB UNTIL COMPLETION
GIVE 24 HOURS NOTICE before any work is covered up

Council inspection are required BEFORE any:

- concrete, masonry infill, grouting, placement
- lining, cladding, roof fixing
- structural frame enclosure
- trim fixing, lining stopping
- plumbing, drainlaying, covering

Deviations from this Document require further approval
Consent holder is responsible and liable for any damage as a result of this work being carried out.

Date: 7/12/07 Building Consent No. 011447

 **MENZIES DESIGNS LIMITED**
ARCHITECTURAL: MECHANICAL
DRAUGHTING AND DESIGN
**MENZIES
DESIGNS**

PROJECT NUMBER A00537

1 PRELIMINARY AND GENERAL

1.1 SCOPE

The scope of the works comprises the erection and completion of the work as detailed on the drawings and specified here-in or as reasonably implied

1.2 GENERAL CONDITIONS

The Contractor shall enter into a contract with the owner as specified and agreed with the Owner. The contract shall be governed by the terms and conditions as required by NZS 3910:1987 and NZMP 3914:1994 unless stated otherwise.

1.3 INSURANCES

Before commencing work Contractors shall arrange insurances to protect themselves and others as required by the General Conditions of Contract to protect against all claims which may arise as a result of this contract. Evidence of insurance cover shall be lodged with the Owner for approval prior to commencement of work. Particular attention should be paid to cover of goods or materials located off site.

1.4 SITE

The Owner is responsible for locating and marking of all site boundaries, building line restrictions, easements etc prior to construction. The Owner shall inform the contractor of any known conditions imposed on the site by the local territorial authority , property developer or any other person or body having any legal, financial or planning authority over the site or building placed thereon. Where required the Owner shall procure a Land Information Memorandum from the territorial authority.

Prior to tendering the Contractor shall inspect the site and ascertain the nature and extent of the work, the means of access to the site, the rights and interests that may be affected by the execution of the works and all other matters referred to in the contract documents which may influence the the contract.

Prior to construction the Contractor shall confirm location of all boundaries, electrical, communication, water, stormwater, sewer and any other services, easements etc on or affecting the site.

1.5 BUILDING CONSENT

The Owner shall apply for the building consent and pay fees as required for building consent application and approval.

The Contractor shall be responsible for issuing all notices of inspection to the Territorial Authority , Building Certifier or Engineer and meeting all building consent and building code requirements.

The Contractor shall keep a record of all inspections carried out by the TA , BC or Engineer and all approvals shall be counter signed by the TA , BC or Engineer and the Contractor.

Where extra inspections or costs are incurred by the Owner due to the failure of the Contractor to comply with the Building Code and/or the contract documents such costs shall be recovered from the contractor by a variation deduction from the contract sum.

1.6 RESOURCE CONSENT

Where a Resource Consent is required for the project the Owner shall be responsible for consent application. The Contractor shall be responsible for ensuring the project is constructed in accordance with the requirements of the Resource Consent together with the Building Consent and contract documents.

1.7 BUILDING CODE

The Contractor and all Subcontractors shall ensure all construction techniques, materials and activities comply with the requirements of the Building Code.

1.8 CONTRACT DOCUMENTS

The documents listed in the SCHEDULE OF CONTRACT DOCUMENTS form the Contract Documents for this project.

1.9 AMBIGUITIES

Should there be any omission or ambiguity in or between the contract documents and the Building Code or Resource Management Act, the Contractor shall seek a ruling from the Owner prior to construction or ordering of materials or plant.

1.10 SUBCONTRACTORS

The Contractor shall supply a list of Subcontractors names to the Owner for approval prior to acceptance of tender.

1.11 STANDARDS

The following abbreviations have been used in this specification;

NZS - New Zealand Standard

NZBC - New Zealand Building Code

In all cases the latest documents and subsequent amendments shall be deemed to be part of this contract.

1.12 PROTECTION OF PROPERTY

The Contractor shall ensure that the site and building structures are adequately protected to prevent loss of plant or materials, injury to persons, damage to this and adjoining sites, structures and property. The Contractor will be held responsible for damage incurred as a result of this project.

1.13 RESPONSIBILITY FOR SAFETY

The Contractor is responsible to ensure construction techniques, personnel protection, work environment, plant, equipment and structures are in compliance with the New Zealand Building Act, NZBC, Health Safety and Employment Act, Occupational Safety and Health requirements, Resource Management Act and all other requirements to ensure safety on site and affected neighbouring sites and personnel.

All personnel employed on the project must be suitably qualified and hold licences or certification if required for their particular field of involvement.

1.14 WORKMANSHIP AND MATERIALS

All work shall be executed in accordance with relevant governing regulations and the contract documents and no deviation will be permitted without the written sanction of the Owner.

Any material or construction found to be defective may be rejected by the Owner at the Contractors expense.

Only competent qualified or suitably supervised persons shall be employed on the project.

1.15 CONSTRUCTION DETAILED

The drawings and specifications show the extent of the construction required but there is no warranty expressed or implied that each and every minor detail or item is detailed. The Contractor is required to allow for all work required to meet the requirements of the contract documents and governing regulations.

Where discrepancies between documents occur the Contractor shall refer such to the Owner for clarification.

Figured dimensions on drawings shall be used in preference to scaling of dimensions. Where any discrepancies occur these shall be referred to the Owner for instructions prior to proceeding.

1.16 EXTRAS AND VARIATIONS

Any extra or variation to the Contract which may result in an alteration to the Contract price and / or compliance with governing regulations must be authorised by the owner in writing. The owner may require confirmation of resulting cost variations prior to issuing approval of such variation.

1.17 PROVISIONAL, PC AND CONTINGENCY SUMS

Any Provisional, Prime Cost or Contingency Sum shall be expended only on the written instruction of the Owner.

Refer to NZS 3910:1987 General Conditions of Contract for definitions of sums.

1.18 POWER TELEPHONE AND WATER FOR SITE

The contractor is responsible for arranging supply of electrical, telephone and water services on the site for the duration of the construction and shall pay all fees and expenses required for same.

1.19 MATERIALS AND PLANT ON SITE

The Contractor shall be responsible for the protection and security of all materials and plant on the site. If any materials or items are delivered on site in a damaged state or of an unacceptable standard the Contractor must inform the Owner immediately for instructions or the Contractor may be held accountable if such items prove detrimental to the project.

The Contractor is responsible to ensure materials plant and fittings on site are protected from theft , adverse weather or damage.

1.20 ATTEND UPON ALL TRADES

The Contractor shall be required to attend upon all Trades and shall render reasonable assistance to Sub-contractors employed on the project.

1.21 PROTECTION OF SURFACE FINISHES

The Contractor shall ensure all necessary precautions are taken to protect surface finishes and completed work from damage during the progress of the project.

1.22 CONSTRUCTION STANDARD

Should any Trade consider the work of another Trade is of an unsatisfactory standard to permit completion of their work to the required standard, the Contractor shall give due notice for rectification prior to further work being commenced.

Failing any notice from the Contractor any Trade will not be absolved of responsibility from completing their work to the required standard.

1.23 DURABILITY OF MATERIALS

Materials, components and construction methods shall be of sufficient durability to meet the requirements of the Contract Documents and regulatory standards. Refer to NZBC B2 for performance requirements of various elements.

Note that durability performances specified are minimum acceptable standard.

1.24 CONTRACT COMPLETION

On completion of all work the Contractor shall issue notice to the Owner that the construction is complete.

The Owner may reject such notice with notification of outstanding work to be completed to Contractual requirements where-upon the Contractor shall arrange for completion and re-issue the notice.

The Owner may reject such notice with notification of outstanding work to be completed to Contractual requirements where-upon the Contractor shall arrange for completion and re-issue the notice.

SECTION 3 : CONCRETE WORK AND REINFORCEMENT

3.01 SCOPE

This section of the specification covers the supply, placing and finishing of all cast-in-place concrete, reinforcing steel and formwork.

3.02 GENERAL

3.2.1 Concrete reinforcing steel details and formwork shall comply with NZS 3109 and subsequent amendments, except where modified by this specification. The Contractor shall ensure that copies of NZS 3109 are available for site use at all times.

3.2.2 The following paragraphs are intended to supplement NZS 3109, and to indicate any required departures from the Standard.

3.2.3 Section and clause references below relate to sections and clauses in NZS 3109.

3.03 FORMWORK, EMBEDDED ITEMS AND CONSTRUCTION JOINTS

These shall comply with section 5 of NZS 3109 and as specified below

3.3.1 Formwork (Clause 5.1)

Fillets and chamfers as appropriate shall be provided at internal and external corners where shown on drawings.

3.3.2 Surface finish (Clause 5.2)

3.3.2.1 General

All exposed concrete surfaces unless specified separately below, shall be formed to give an appearance in accordance with F4 finish of NZS 3114. All surfaces not exposed shall be formed to an F3 finish.

3.3.2.2 Treatment of Holes

All shee-bolt holes and the like shall be filled with dry mortar, rammed hard. Finishing shall be carried out using a hard stone with bagging of the area as required. The mortar mix shall be approved by the Engineer on the basis of colour and texture matching.

3.04 SUPPLY OF CONCRETE

All concrete to be used in the work shall comply with NZS 3109 section 6, except as modified below. The technical requirements defining the concrete are also nominated.

3.4.1 Specified Strength (Clause 6.1.1)

The specified concrete strength to be used in the work shall be 25MPa except non structural site concrete to be 10MPa.

3.4.2 Aggregates (Clause 6.4.2)

The maximum aggregate size to be used shall be 20mm.

3.4.3 Cement (Clause 6.3)

Cement shall conform to NZS 3122. Rapid hardening portland cement shall not be used.

3.4.4 Production Standards

3.4.4.1 Ready mixed shall be used.

Ready mixed concrete shall comply in all respects with NZS 2086. A current grading certification from the New Zealand Ready Mixed Concrete Association will be accepted as compliance with this standard.

Delivery dockets shall be supplied by the producer for each load. Dockets shall contain as a minimum the following information:

- (a) Class of concrete.
- (b) Date and time of mixing.
- (c) Quantity delivered.
- (d) Identifying number of truck.
- (e) Slump.
- (f) Any special information pertaining to the batch which may be required from time to time by the Engineer, such as type and quantity of additives, cement content etc.

3.4.4.2 Pump mix concrete may be used, but any variation from the requirement of this specification must be authorised in writing by the Engineer before the concrete is delivered to the site.

3.4.5 Slump

The maximum slump shall be 75mm to isolated footings, all slabs and beams. Prior approval in writing must be obtained from the Engineer for increased slumps to be used.

3.3.3 Removal of Formwork (Clause 5.4)

Cylinder tests for the purpose of reducing stripping times shall be the Contractor's own expense. Strength requirements for stripping will be laid out by the Engineer.

3.3.4 Chases, Recesses and Cast-in Items (Clause 5.5)

All chases and recesses for the flashings, conduits, fittings, etc, shall where possible be formed in the concrete work. Subsequent cutting out of concrete for these purposes shall be avoided where possible. Cast-in items and proprietary fixings, shall be incorporated as required. All bolts fixed into concrete work shall be accurately fixed to line, level and location, and fixed by template to ensure rigidity during concreting.

The Contractor shall allow for casting in conduits as required by the electrician.

Galvanised steel pipes shall be wrapped in Denso tape where in contact with concrete. All PVC services shall pass through a 50mm oversize hole as specified in NZS 4452.

All openings shall be plugged around the service pipe to prevent ingress of moisture below ground level and to prevent passage of fire and moisture above ground level in floors and walls.

3.3.5 Construction Joints (Clause 5.6)

The shape and location of construction joints shall be to the Engineer's approval prior to the commencement of work on the particular section of the work. The location of saw cut joints shall be as shown on the drawings.

3.4.6 Tests During Construction

The Contractor shall allow for sampling and casting of test cylinders and arrange for testing.

3.05 CONCRETE PLACING, FINISHING AND CURING

These shall be as Section 7 of NZS 3109. Additional requirements are as follows:

3.5.1 General

No concrete shall be deposited in the forms until they have been inspected by the Engineer and approval to proceed has been given.

3.5.2 Finish of Slabs (Clause 7.6)

Unless noted as broom finish on the drawings, the surface finish to slabs shall be in accordance with U3 finish of NZS 3114. The required finish shall be obtained by the use of a powered float. All areas noted as a broom finish shall be in accordance with U5 finish of NZS 3114.

3.5.3 Curing (Clause 7.7)

Slabs shall be cured by the application of an approved curing compound or by keeping the exposed slab surface continuously damp for seven days after casting. Any type of curing compound which prevents the adhesion of subsequent surface finishes shall not be used.

3.06 REINFORCING STEEL

3.6.1 All reinforcing used in the work shall comply with section 3 of NZS 3109 and NZS 3402 and is to be sourced from Pacific Steel unless alternative source is approved by the Engineer. Additional requirements as follows:

3.6.1.2 Fixing of reinforcement (clause 3.4)

Welding of grade 300 and 430 reinforcement shall be in accordance with NZS 4701, NZS 4702 and to the approval of the Engineer.

Do not weld within 80mm of a bent portion of a cold bent bar. Welding must not be undertaken when it is raining, during periods of high winds or where steel temperature is below 0°C.

When welding large diameter bars, adequate preheating of joints is required.

3.6.2 Bends

The internal diameter of all bends is to comply with Tables 7.1 and 7.2 of NZS3101:Part1:1995 as appropriate, unless specified otherwise on the drawings. Crushing of the deformations on the inside radius will be cause for rejection of the reinforcing steel.

3.6.2 Laps

3.6.2.1 Smooth Wire Mesh

2 crosswires plus 75mm to give a total of 225mm.

3.6.2.2 All other laps as shown on drawings.

3.6.3 Electrical Earth

Before the placement of concrete to the foundations the Contractor shall allow to weld an earth connection to the foundation steelwork. The location of the earth connection will be advised by the Electrical Contractor on site.

3.07 REMOVAL OF FORMWORK AND DEBRIS

All formwork shall be removed from finished concrete work.

5 CARPENTRY

5.1 PRELIMINARY

Refer to the Preliminary and General section of this specification and the General Conditions of Contract, the clauses of which are equally binding on this section.

5.2 SCOPE

The scope of this trade covers the work and supply and fixing of all materials and equipment as detailed in the contract documents normally executed by carpenters and includes all attendance and setting out for other trades as required.

5.3 GENERAL

The work shall be executed by competent trades people in accordance with the contract documents, NZS 3604, the NZ Building Code and territorial authority requirements. Materials shall be the best available quality and any materials which are not of the required standard shall be removed from the site as directed by the Owner or building supervisor.

5.4 TIMBER

Timber shall be of the types shown or specified and in accordance with NZS3602, and NZS 3605. Treated timber shall be pressure treated in accordance with the requirements of NZMP 3640;1992 - specification of the minimum requirements of the NZ Timber Preservation Council Inc.

5.5 SEASONING AND MOISTURE CONTENT

Timber shall be well seasoned. Any timber delivered to the site in an unseasoned condition shall be fillet stacked and seasoned to the satisfaction of the Owner. Radiata Pine timber for framing shall have a moisture content not exceeding requirements specified below based on oven dry weight. Joinery and dressing timbers, before machining, shall be seasoned or kiln dried to a moisture content of 12% to 18% based on oven dried weight or within 3% of the average moisture content likely to be attained in service.

The following approximate general Equilibrium Moisture Content figures for sheltered outdoor positions have been compiled by the New Zealand Forest Service Research Institute and are based on the known humidity and temperature averages for the localities concerned.

Nelson Area

January

Sap Rimu	13.5%	Sap Radiata Pine	12.1%
----------	-------	------------------	-------

July

Sap Rimu	18.9%	Sap Radiata Pine	17.4%
----------	-------	------------------	-------

Maximum acceptable moisture content.

- a: Framing timber at the time of installing interior linings: 24%.
- b: Timber weatherboards and exterior joinery at time of painting: 20%.
- c: Reconstituted wood products: 15%.

Refer to specific requirements for lining materials as specified by manufacturer.

5.6 TYPES AND GRADES OF TIMBER

Classification and grading of timber shall be in accordance with NZS 3602. All timber used shall be gauged to produce regular plane surfaces when used to support linings. Other timber members may be rough sawn if desired.

Timber types shall be as the following schedule:

Interior

Wall framing	Radiata Pine No 1 framing H1 treated or Douglas Fir equivalent.
Roof framing	Radiata Pine No 1 framing H1 treated or Douglas Fir equivalent.
Exposed beams	Douglas Fir

Exterior

Exposed beams	Radiata Pine H4
Timber posts	Radiata Pine H4
Timber trim	Radiata Pine finger jointed H3

5.7 PRIMING

Before fixing timber trim all joints and laps abutting exterior finishing timbers and external timber windows and doors shall be primed with an approved primer.

5.8 FLOOR FRAMING

Where timber framed floors are shown construct with joists to sizes indicated on drawings. Lay 20mm flooring grade particle board or T&G as detailed (see lining schedule) to areas shown. Sand floor at completion of job. Securely support and fix all edges to stop movement. Refer to NZBC E2/AS1 Clause 4.

5.9 DAMP ROOF COURSE

Provide and fix a continuous 3 ply malthoid DPC between all timber in contact with any concrete products. Refer to NZBC E2/AS1 Figure 4.

5.10 WALL FRAMING

Frame up wall to thickness shown on drawings or specified. All stud and dwang sizes shall be in accordance with NZS 3604:1990.

Studs shall be spaced as shown to suit joints in lining materials. Three studs shall be provided at external corners, changes of direction or intersections. Double studs shall be provided at each opening, one full height and the other under the lintel. Double studs shall also be provided under ridge beams.

Dwangs shall be at centres shown. Provide all necessary dwangs for joinery fittings, hardware etc.

Lintels shall be as detailed on the drawings or to comply with NZS 3604, support with double studs as above.

5.11 ROOF FRAMING

Joints in all members shall be at support points only. Sizes shall be as detailed on drawings or as specified in NZS 3604:1990.

Trusses: where detailed shall be fixed plumb, fastened on to top plates with framing anchors, stiffened with runners and braced at each end of the building and as per truss manufacturers design requirements the trusses shall have a supporting dwang fixed under top plate or be positioned directly over studs.

5.12 CEILING FRAMING

Ceiling framing shall be constructed as shown on the drawings, as required by manufacturer of ceiling lining and in accordance with NZS 3604. Strapping shall be gauged and fixed to ensure ceiling will be flat when fixed in position.

5.13 BRACING

Bracing shall be as shown on the drawings to comply with the bracing schedule and details in accordance with NZS 3604. Allow to supply and fix all bracing materials including fastenings.

5.14 BUILDING PAPER

Line exterior of all walls and where required roof with fire retardant building paper in accordance with NZBC E2/AS1 Clause 2.4.

5.15 INSULATION

Provide and install wool block insulation to ceiling and walls as shown in accordance with manufacturers recommendation and as required by NZBC G5. Refer to NZBC G6 for noise attenuation requirements for airbourne and impact sound.

5.16 FLASHINGS

Flashings shall be as detailed and in accordance with standard trade practice. Do not use sealants where real flashings are required. Typical flashing details are specified in BRANZ Bulletins 304 and 305 Feb 1993.

5.17 SEALANTS

Where sealants are permitted to be used they shall be selected appropriate for intended use and shall be applied in accordance with manufacturers specification including priming, masking etc.

Particular attention shall be paid to minimum joint size.
Fillet type seals will not be permitted.

5.18 FINISH

All exposed timber shall be dressed to a smooth surface. Internal joinery and finishing timbers shall be brought to a smooth and even surface by sandpapering. Remove all arrises, hammer marks, rough edges and uneven patches and all other surface defects before painting.

5.19 EXTERNAL LININGS

External linings shall be as shown on the drawings.

Fix lining in accordance with manufacturers specification and NZBC E2/AS1.

5.20 INTERNAL LININGS

Internal lining materials shall be as per lining schedule.

Fix linings in accordance with manufacturers specification and NZBC E3/AS1.

5.21 COMPLETION

On completion remove all rubbish from site, clean the building and leave ready for occupation.

6 JOINERY

6.1 PRELIMINARY

Refer to the preliminary and general sections of this specification, the clauses of which are equally binding on all sections.

6.2 SCOPE

The scope of this trade covers the supply of materials and equipment and all work required to construct and fit the joinery items as detailed on the drawings.

6.3 MATERIALS

All materials used shall comply with the standards set out in NZS 3602. All timber shall be thoroughly seasoned or kiln dried, with a moisture content of less than 12%. Timber shall be straight and true and free from distortion and in lengths suitable for the situation required. All timbers shall comply with the grading requirements of NZS 3631. Treated timber where specified shall be treated as approved by the Timber Preservation Authority. Where Radiata Pine is used as an exposed finishing timber, boric treatment shall be used.

All exposed timber, sheets, panels and veneers used in joinery and cabinetwork shall be the best of their respective kinds, free from distortion or defects which would prevent a good dressed surface and acceptable finish. Should any material used be rejected by the owner the Joiner shall replace the material and make good the work at his own cost.

6.4 WORKMANSHIP

All connections whether nailed, screwed, glued, morticed or dovetailed shall be accurately made and properly executed to provide sound satisfactory connections for the class of work required. In exposed work all nails shall be well punched and screws adequately countersunk to allow for finishing with stopping work. All joinery shall be factory made in accordance with good trade practice by skilled tradespeople with the most accurate set-out and tolerances and by proper tools, jigs, machines and equipment appropriate for the work. All workmanship shall be strictly to the approval of the owner who shall determine the standards of workmanship required under this section.

Dimensions of joinery units shall be checked on the site before work is commenced in the factory. Door openings and access on the job shall be checked to ensure that factory made units may be taken into place, and units shall be manufactured in sections as necessary to achieve this.

Allow sufficient clearance on joinery for paint thicknesses and floor coverings. Where Formica tops fit against wall surfaces, the edge of the Formica trim shall be scribed to the wall surface and fitted on the job to avoid the need for applied mouldings or trim.

6.5 FINISH

All joinery work shall be executed with timber machine dressed on four sides and hand dressed and sanded on all exposed surfaces. All arrises in any way accessible and visible shall be sanded and smoothed off.

6.6 PROTECTION OF MATERIALS, JOINERY & CABINET-WORK

Materials used in joinery and cabinetwork shall be protected from physical and weather damage in the factory and during transport to the site. The Joiner shall co-operate with the Main Contractor to ensure that cabinetwork and joinery is delivered to the site when required and in fine weather conditions.

After delivery to the site in undamaged condition, protection of joinery on the site shall be the Main Contractor's responsibility.

6.7 HARDWARE

Supply and fix all hinges and stays. Make allowance for all clearances, tolerances, blocking and other fixing requirements for the hardware.

6.8 FORMICA TOPS

Provide and fix Formica tops to kitchen benches and vanity units. Tops shall have a rolled bullnose edge.

6.9 COMPLETION

Make good all marks, scratches, cracks, gaps or other disfigurements and remove any excess glue. Leave prefinished materials clean and ready for use.

7 ROOFING

7.1 PRELIMINARY

Refer to the preliminary and general section of this specification, the clauses of which are equally binding on all sections.

7.2 SCOPE

This section covers the supply and installation of cladding to the roof including where required, battens, flashings and fasteners.

7.3 GENERAL

The work shall be executed by trades people competent in this type of work to the satisfaction of the owner and territorial authority and in accordance with NZBC E2/AS1, NZS 3604 and manufacturers specification.

7.4 UNDERLAY

Underlay shall be breather type fire retardent building paper supported on galvanised wire netting or similar approved support.

7.5 PREFINISHED LONG RUN STEEL

Long run roofing shall coated steel, BMT as noted on the drawings. Profile and colour shall be as selected by the owner. Sheets shall where possible be fitted in single runs with laps as specified by the manufacturer. Extreme care must be taken to ensure coatings are not damaged prior to or during fixing.

The roof shall be fitted complete with matching ridge, hip and barge caps where required and all flashings. All exposed fasteners shall be colour coordinated. Roof must be completely weather tight and bird proof.

7.6 COMPLETION

On completion remove all drilling, rivet mandrels etc and wash down roof. Leave roof and gutters clean and free from any debris. Remove all rubbish from the site and have a nice day.

8 WINDOWS AND DOORS

8.1 PRELIMINARY

Refer to the preliminary and general sections of this specification, the clauses of which are equally binding on all sections.

8.2 SCOPE

This section covers work customarily done by joiners as shown on the plans specified herein or reasonably implied. Windows and doors shall be aluminium, unless otherwise indicated on the drawings.

8.3 GENERAL

Supply and deliver to site windows and doors required by this trade complete with flashings, glazing and hardware. Aluminium joinery shall be constructed to comply with NZS 4211, NZS 3504 and NZBC F 2.

8.4 GLAZING

Glazing shall comply with NZBC F2/AS1 and NZS 4223. Note that NZS 4223 shall be modified as required by NZBC F2/AS1 Clause 1.

8.5 SEALANTS AND FLASHINGS

Seal all windows and doors as required to ensure a weather tight unit. Flashings shall be supplied by this trade and shall be of a material suitable for the joinery. Aluminium flashings shall be anodized or powder coated as required to match joinery finish.

8.6 TIMBER REVEALS

Where the specified window is designed for fixing to timber reveals, these shall be constructed from finger jointed H3 radiata. All joints shall be neatly mitred and glued.

8.7 DELIVERY AND STORAGE

Co-operate with the Main Contractor to ensure that the doors and windows are delivered in suitable weather conditions and can be unloaded into a suitable place of storage. Care shall be taken to avoid damage to components during transport and loading/unloading operations.

Protection of components once in storage on the site shall be the responsibility of the Main Contractor, who shall inspect the components upon delivery and notify the Owner of any defects or damage immediately on delivery to the site. Failure of the Main Contractor to notify shall be deemed as acceptance of the components in good order.

8.8 FINAL CLEANING

Upon completion of the metal window and door installation (including glazing) and with the approval of the Owner, all protective covering (if any) shall be removed from all exposed finished surfaces and these surfaces including glazing shall be cleaned ready for acceptance by the Main Contractor. Any subsequent

protection and/or cleaning, if required shall be the responsibility of the Main Contractor

8.9 GUARANTEE

Before final payment is made, the Contractor shall guarantee to the Owner in writing that all parts of the work will meet the specified overall performance requirements of the specifications, and shall guarantee the materials and workmanship for a period of two (2) years following its acceptance by the Owner.

9 SOLID PLASTER

9.1 PRELIMINARY

Refer to the preliminary and general sections of this specification, the clauses of which are equally binding on all sections.

9.2 SCOPE

The scope of this trade covers the work undertaken by plasterers.

9.3 GENERAL

The work shall be executed by competent approved trades people competent in the application of reinforced solid plaster. The supply of materials and application shall be in accordance with the requirements of NZBC E2 / clause 2, NZS 3604, local Territorial Authority requirements and to the satisfaction of the Owner. It is recommended that the Plasterer refer also to the BRANZ publication "Good Stucco Practice".

9.4 BACKING

Backing shall be as stated on the drawings.

Rigid backing shall be fixed to studs and dwangs in accordance with backing manufacturers recommendations. Where required fix building paper over plywood backing.

Non rigid backing shall be fixed in the following manner;

Stud centres shall not exceed 400 mm, heavyweight breather type fire retardent building paper shall be fixed to studs and dwangs. Fix 200mm thick H3 vertical battens over studs with 60x2.8mm galvanised flat head nails at 300mm centres maximum. Any horizontal battens should be out of level and cut short of vertical battens to allow vertical flow of moisture. The bottom edge of the plaster shall be fitted with a galvanised iron screed strip to provide rigidity and vermin proofing. Fit galvanised wire netting over battens and line with building paper and apply reinforced solid plaster as per normal.

9.5 PLASTER AND REINFORCEMENT

The plaster system shall be a three coat system to comply with NZS 4251 to a minimum thickness of 21mm, and shall be reinforced with galvanised wire netting spaced 9mm out from backing or with self furring reinforcing. Control joints shall be spaced at 4 metres centres vertically and horizontally and at corners of openings likely to promote cracking. Install diagonal reinforcing strips at corners of windows and doors.

9.6 COMPLETION

On completion clean all plaster droppings from surfaces exposed to view and remove all rubbish from site.

10 ELECTRICAL

10.1 PRELIMINARY

Refer to the preliminary and General section of this specification the clauses of which are equally binding on this section.

10.2 SCOPE

The scope of this contract covers the work normally undertaken by an Electrician.

10.3 GENERAL

The work shall be executed by competent approved tradespeople holding such licences or certification as required for the work undertaken. The installation and components shall comply with the NZ Building Code, the Electrical Wiring Regulations and current NZ Standards and amendments. Coordinate with other trades as required. Notify the Main Contractor of positions and details for ducts, holes or recesses etc required in or under concrete construction, the requirement of dunnage, blocking etc for fixing of fittings.

10.4 PERMITS AND FEES

The Electrical Contractor shall notify the Supply Authority of the installation and obtain all permits and pay all fees, arrange all required inspections and pay associated fees.

10.5 CONNECTION TO SUPPLY

Connect to existing electrical system, install new MCBs at to distribution board as required.

10.6 CIRCUIT CABLES

Switched socket circuits; Install TPS circuit wiring to all switched socket positions indicated. Maximum number of outlets per circuit shall be four. Lighting circuits; Install TPS circuit wiring to all light fittings indicated. Maximum load per circuit shall be 1kW.

Appliances; Install TPS circuit to all appliances including hot water cylinder elements etc.

All holes for cables drilled through framing shall be positioned on centre of member in positions which will not diminish the structural integrity of the framing.

10.7 LIGHT SWITCHES

Light switches shall generally be mounted 1200mm above floor level in positions shown. Switches shall be PDL600 series , white, or HPM Excel range, white, unless specified otherwise in electrical schedules. Refer to NZBC G9 clause 2 for requirements relating to disabled persons. All mounting positions shall be confirmed by the Owner on site prior to final installation.

10.8 SWITCHED SOCKETS

Switched sockets shall generally be mounted 500mm above floor level, with sockets above benches or for appliances located as required to allow for ease of use and safety requirements. Note requirements relating to provision of RCD units. Sockets shall be PDL600 series, white, or HPM Excel range, white, unless specified otherwise in Electrical Schedules. Refer to NZBC G9 clause 2 for requirements relating to disabled persons. All mounting positions shall be confirmed by the Owner on site prior to final installation.

10.9 COMPLETION

On completion leave installation clean and tidy and operating correctly. Pass all warranties, certificates etc to Owner and remove all rubbish from the site.

11 PLUMBING

11.1 PRELIMINARY

Refer to the Preliminary and General section of this specification and the General Conditions of Contract, the clauses of which are equally binding on this section.

11.2 SCOPE

The scope of this trade covers the supply of materials and equipment and installation to provide a complete plumbing service.

11.3 GENERAL

The work shall be executed by competent approved trades people holding such qualifications and / or certification as required for the work undertaken and in accordance with the NZ Building Code and Territorial Authority requirements. The Carpenter is responsible for provision of all framing, blocking etc for the support of fittings but the Plumber shall be responsible for co-ordination of such attendance. Holes for pipes shall be of minimum size required and shall be positioned to ensure structural integrity of the building is not compromised.

11.4 PREPARATORY WORK

Co-ordinate with the Main Contractor for provision of ducts, trenches, cut-outs etc required in concrete slabs and foundations etc. Inspect the site prior to tendering and make all necessary allowances for connection to existing services. The Plumber shall be responsible for damage done by this trade to other services, structures etc and shall make good at own expense.

11.5 MATERIALS

All materials shall conform to NZ Standards requirements. Water pipes shall be copper unless otherwise directed by the Owner. Wastes shall be PVC. Careful attention must be paid to installation of materials in positions likely to cause galvanic or electrolytic corrosion.

11.6 FITTINGS

Install fittings in positions shown on the drawings and connect to existing services as required and detailed. Supply and fit all discharge traps required for sanitary fittings shown and as required by NZBC G12/AS1.

11.7 HOT WATER RETICULATION

All hot water reticulation piping shall be copper unless otherwise directed by the Owner. Refer to NZBC G12/AS1 table 5 for acceptable materials and jointing and table 7 for pipe support details. Hot water to fittings shall be tempered by an approved tempering valve or mixing valve regulated to prevent scalding.

11.8 COMPLETION

On completion confirm completion of pressure tests, operation of system etc, clean all fittings and remove all rubbish from site.

12 DRAINLAYER

12.1 PRELIMINARY

Refer to the preliminary and general sections of this specification, the clauses of which are equally binding on all sections.

12.2 GENERAL

The work shall be executed by competent tradespeople approved by the territorial authority and registered in accordance with the "Plumber, Gasfitters and Drainlayers Act 1976". The work shall comply with the NZ Building Code.

12.3 SCOPE

This section covers work customarily executed by drainlayer as shown on the drawings specified herein or reasonably implied. Allow to supply and install all materials required for this trade including trench excavation, backfilling, shoring, protection and safety requirements.

12.4 DRAINAGE PLAN

Drains shall be layed as per the drainage plan and in accordance with NZBC G13/AS2 Clause 2. An amended drainage plan shall be submitted to the territorial authority if any alterations are made to the plan.

12.5 GULLY TRAPS

Install gully traps where shown and in accordance with NZBC G13/AS2 Clause 3.

12.6 MANHOLES AND SUMPS

Supply and install manholes and sumps as detailed on the drawings and in accordance with Nelson City Council and Building Code requirements complete with lids, grates etc.

12.7 PIPES

Pipes shall be laid at an even gradient. Diameters shall not decrease in direction or flow. Refer to NZBC G13/AS2 Table 2 for sizes and gradients. Pipes shall be UPVC to comply with NZS 7649 unless otherwise shown.

12.8 DRAIN VENTILATION

Drains shall be ventilated with vent pipes as shown and in accordance with NZBC G13/AS2 Clause 6.

12.9 TRENCHES

Excavate trenches as requested to allow adequate working room for pipe laying and jointing. Refer to NZBC G13/AS2 Figure 7 for proximity to buildings. Pipes shall be kept free of dirt etc which may cause blockages.

Bedding material shall have a maximum particle size of 20mm. Trenches shall be backfilled in accordance with NZBC G13/AS2 Clause 8 and Figure 6.

12.10 MAINTENANCE

Drains shall be provided with adequate maintenance access points. Access points shall be constructed in accordance with NZBC G13/AS2 Clause 9 and shall be located as shown and/or as per NZBC G13/AS2 Clause 9.3.

12.11 DRAIN INTEGRITY

Drains shall be completely water tight on completion in accordance with NZS 7643: Section 11 and NZS 4452: Section 11.

12.12 COMPLETION

On completion dispose of all rubbish and surplus soil backfill material unless otherwise directed by the owner.

13 GLAZING

13.1 PRELIMINARY

Refer to the Preliminary and General Section of this specification and the General Conditions of Contract the clauses of which are equally binding on this section.

13.2 SCOPE

The scope of this trade covers the supply of materials and equipment and installation required to provide a complete glazing system.

13.3 GENERAL

The work shall be executed by competent trades people suitably qualified for the work involved. The Glazing system shall comply with the NZBC F2/AS1 and NZS4223 parts 1 and 2 1985 Code of Practice for Glazing in Buildings, and Part 3 1993 Human Impact Safety Requirements. Further to these codes, ALL glass in doors, door side panels and windows with a sill line below 800mm above floor line shall be fitted with safety glass.

13.4 STANDARD OF WORK

Neatly cut and fit all glass into rebates or frames provided. Coordinate with the Main Contractor and Joiner for installation of glass. Where glazing into paint finished work ensure that all rebates are well primed and free of dirt and foreign matter.

13.5 GLASS TYPES

Refer to plans and schedules for glass types and / or tinting required.

13.6 BUTT JOINTS

Where butt joints are required, glass edges shall be square and clean. Fill joints with clear silicone sealant in accordance with manufacturers instructions. Smooth off and remove excess sealant to give a neat clean finish.

13.7 COMPLETION

On completion clean all surfaces, remove all rubbish from site and have a nice day.

14 PAINING AND WALL COVERINGS

14.1 PRELIMINARY

Refer to the Preliminary and General section of this specification and the General Conditions of Contract the clauses of which are equally binding on this section.

14.2 SCOPE

The scope of this trade covers the supply and application of paint, coatings, or wall coverings as specified and as directed by the owner.

14.3 GENERAL

The work shall be executed by competent approved tradespeople.

All paint and finishing systems shall be applied in accordance with the manufacturers specifications, NZS 7703 and the related documents set out in that standard.

All paint, coating and covering systems shall comply with the NZBC, and in particular, NZBC B2 durability, NZBC C3 spread of fire, NZBC E2 and E3 external and internal moisture.

14.4 MATERIALS

All materials shall be of top quality from reputable manufacturers complying with the NZ Standards. All coatings shall be delivered in sound sealed containers clearly labelled.

Paints specified in any one paint system shall be obtained from the same manufacturer.

Specific paint manufacturers or suppliers may be mentioned in this specification. Other manufacturers or suppliers offered by the Contractor must be approved by the Owner.

All materials and equipment shall be stored in clean conditions free from possible contamination or adverse temperature.

14.5 INSPECTION OF SURFACES

The Painter shall inspect the finish of surfaces to be painted or coated etc, and report to the Contractor any deficiencies, defects, blemishes or contamination which could affect the provision of a high standard of finish. Painting shall not commence until any such deficiencies have been rectified.

14.6 WEATHER CONDITIONS

Painting shall not be carried out during inclement weather or temperatures outside manufacturers specified acceptable range.

14.7 SCAFFOLDING AND EQUIPMENT

Supply all scaffolding, staging and safety equipment required to execute the work in accordance with governing regulatory requirements and to allow application of sound trade practice.

14.8 ATTENDANCE

The Painter shall co-operate with the Contractor and other Trades and arrange work to cause the minimum of inconvenience or delay. The Painter shall be responsible for any damage or deficiencies caused by inadequate work or programming.

14.9 STOPPING

Stopping shall be executed as follows;

- a) Gib board; as per ISA Levels of Gib Board Finish specification.
- b) Concrete, solid plaster or brickwork; similar material to substrate finished with matching texture.
- c) Painted woodwork or wood based products; putty or plastic filler.
- d) Clear finished woodwork or wood based products; putty tinted to match finished work.

14.10 PRE-PAINTING

The Painter shall co-operate with the Contractor to ensure all components requiring pre-painting prior to fixing are catered for.

14.11 COLOURS AND SAMPLES

The Owner will supply a colour specification.

The Painter shall give a minimum of three weeks notice for supply of colour specification.

When requested by the Owner the Painter shall supply samples of at least one square metre of colours or textures for approval and confirmation.

14.12 PAINT SCHEDULE

Refer to the Painting Schedule for paint types.

Note that other systems may be offered by the Painter but will require the prior approval of the Owner.

14.13 CUPBOARD INTERIORS

All interior surfaces of cupboards including doors and shelves shall be painted unless components are supplied prefinished.

14.14 TOUCH-UP WORK

The Painter shall allow for removal and refitting of hardware, electrical cover plates etc and the repainting of joinery or fittings where necessary after fitting and easing by the Carpenter or Joiner.

14.15 COMPLETION

On completion remove all equipment, rubbish etc from the site sweep floors, clean and leave building ready for occupation.

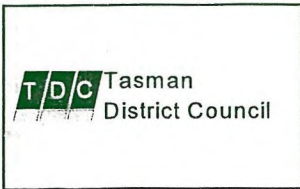

APPLICATION FOR BUILDING CONSENT
Section 33, Building Act 1991

Building Consent No.	95/888
Date Issued	20/12/98

TO: TASMAN DISTRICT COUNCIL
PART A: GENERAL

APPLICANT¹

Name: NICK HERRON

Mailing Address: PO BOX 980, NELSON

Contact Name: AS ABOVE

Position: OWNER

Phone: 5446912 Fax: _____

PROJECT LOCATION

Street Address: BEST ISLAND

LEGAL DESCRIPTION

Valuation Roll Number: 19380934 00

Lot: 36 DP: 5096

Section: 809 m² Block: II

Survey District: WAIMEA

VALUE OF PROPOSED PROJECT

The Council's charges payable on the making of this application are based on the estimated value (GST inclusive) of:

Building \$ 4,300-00

Plumbing/Drainage (labour only) \$ 300-00

Total \$ ~~4,600-00~~ 6,000-00

PROJECT

Intended Use(s) (in detail): EXTENSION

OF KITCHEN
Recladding - Plastered

New Dwelling(s)

Alterations to Dwelling(s)

Domestic Garage(s)

Shed(s) and Other(s) (e.g. foundations demolition)

Heating

Other new construction

Intended Life:
Indefinite, but not less than fifty years
Specified as _____ years

Demolition

Being Stage _____ of _____ stages

PLAN/ZONE

This application is for:

Building consent only, in accordance with project information memorandum No. _____

Both building consent and a project information memorandum.

¹Under Section 33 of the Building Act, the applicant must be the owner of the land on which building work is contemplated or a person who or which has agreed in writing, whether conditionally or unconditionally, to purchase the land or any leasehold estate or interest in the land, or to take a lease of the land, while the agreement remains in force.

PART B: PROJECT DETAILS

(Complete Part B only if you have not applied separately for a project information memorandum.)

The project involves the following matters (cross each applicable box, if any, and attach relevant information in duplicate):



- Location in relation to legal boundaries, and external dimensions of new, relocated, or altered buildings.
- New provisions to be made for vehicular access, including parking.
- Provisions to be made in building over or adjacent to any road or public place.
- New provisions to be made for disposing of stormwater and wastewater.
- Precautions to be taken where building work is to take place over existing drains or sewers or in close proximity to wells or watermain.
- New connections to public utilities.
- Provisions to be made in any demolition work for the protection of the public, suppression of dust, disposal of debris, disconnection from public utilities, and suppression of noise.
- Any cultural heritage significance of the building or building site, including whether it is on a marae.

PART C: BUILDING DETAILS

This application is accompanied by (cross each applicable box and attach relevant documents in duplicate):

- The drawings, specifications, and other documents according to which the building is proposed to be constructed to comply with the provisions of the Building Code, with supporting documents, if any, including:
 - Building Certificates.
 - Producer Statements.
 - References to accreditation certificates issued by the Building Industry Authority.
 - References to determinations issued by the Building Industry Authority.
 - Proposed procedures, if any, for inspection during construction.

PART D: KEY PERSONNEL

Names/Addresses/Telephone Numbers	Registration No.	Signature
Builder(s): SELF		
★ Registered Drainlayer: SELF S. Millson		
★ Craftsman Plumber:		
Designer(s): ALLAN WALTERS		
Building Certifier(s):		
Other: RON O'HARA REGD ENG REGD ENG		

* The Craftsman Plumber/Registered Drainlayer are to complete a separate advisory sheet. This advisory sheet is to be returned to Council prior to work commencing.

PART E: COMPLIANCE SCHEDULE DETAILS

E1: SYSTEMS NECESSITATING A COMPLIANCE SCHEDULE

(Complete Part E1 for all new buildings and alterations, except single residential dwellings.)

The building will contain the following (cross each applicable box and attach proposed inspection, maintenance, and reporting procedures):

- Automatic sprinkler systems or other systems of automatic fire protection.
- Automatic doors which form part of any fire wall and which are designed to close shut and remain shut on an alarm of fire.
- Emergency warning systems for fire or other dangers.
- Emergency lighting systems.
- Escape route pressurisation systems.
- Riser mains for fire service use.
- Any automatic back-flow preventer connected to a potable water supply.
- Lifts, escalators, or travelators or other similar systems.
- Mechanical ventilation or air conditioning system servicing all or a major part of the building.
- Any other mechanical, electrical, hydraulic, or electronic system whose proper operation is necessary for compliance with the Building Code.
- Building maintenance units for providing access to the exterior and interior walls of buildings.
- Such signs as are required by the Building Code in respect of the abovementioned systems.
- None of the above.

E2: OTHER SYSTEMS AND FEATURES TO BE INCLUDED IN THE COMPLIANCE SCHEDULE

(Complete Part E2 only if the building contains one or more of the systems listed in Part E1.)

The building will contain the following (cross each applicable box and attach proposed inspection, maintenance, and reporting procedure):

- Means of escape from fire.
- Safety barriers.
- Means of access and facilities for use by persons with disabilities which meet the requirements of Section 25 of the Disabled Persons' Community Welfare Act 1975.
- Hand-held hoses for fire fighting.
- Such signs as are required by the Building Code or Section 25 of the Disabled Persons' Community Welfare Act 1975.

PART F: STATISTICAL INFORMATION

Please answer the following questions if they apply:

Floor area: 14 m² No. of dwelling units: 1 No. of storeys: 1

Confidentiality:

Section 27 of the Building Act states that the records of Council shall be made available for public inspection. Subsection 3, however, allows an owner to mark plans and specifications as confidential due to copyright or security reasons.

Please indicate if you require plans/specifications to be marked as confidential. YES/NO

Signed by/for and on behalf of the applicant:

Name: [Signature]

Position: OWNER Date: 18-12-95

Important Note: Depending on the area you live, and if you are connecting to the Council's sewerage or water, a connection fee may be payable. For further information please obtain the guide titled "Residential Sewer and Water Connection Fees" from Council offices.

COUNCIL USE ONLY

Checked By:	Initials	Date
Plumbing & Drainage		
Design		
Health		
Planning		

Building	\$ <u>240.00</u>
Plumbing/Drainage	\$
BRANZ Levy	\$
BIA Levy	\$
Demolition	\$
Dependent Relative	\$
Log Burner/Space Heater	\$
TOTAL	\$
Tax Invoice sent	\$
	\$

Approved for issue of Building Consent

Technical Officer: [Signature]

Date: 18 / 12 / 95

Receipt No.

Consent Fees Payable (GST incl):

Council bases its fee on the cost of processing the total building project as follows:

- (a) **Administration:**
Receiving and issuing the consent plus checking plans etc. for Building Code compliance.
- (b) **Inspections:**
Council is required to inspect certain stages and elements of construction for Building Code compliance.
- (c) **Code Compliance Certificate:**

At the project's completion, Council will, if satisfied work complies to the Building Code, issue a certificate, which is an important document for future property dealings.

Handwritten: Paid \$240.00
19/12/95

PIM/BUILDING CONSENT APPLICATION COVER SHEET

Applicant: NICK HERRON	
Application No: 951888	Date Received: 18/12/95
PIM Issued:	Electrical:
Engineering:	Planning:
EHO:	Consent Officer: Lynda

CHECK LIST

Two Sets of Plans and Specifications	Bracing Schedule and Subfloor Bracing	Certificate of Title	Accurate Site Plan (include drainage locations and connection points)	Cross-section
Truss Number	Schedule of Materials	Historical Places Trust	Land Notification	Generate Invoice Y/N

BUILDING

Special Condition - Issued just following completion - Inspection revealed Done to good st 1.

TECHNICAL OFFICER:	DATE: 18/12/95
--------------------	-----------------------

HEALTH (Domestic Services)

P001, P004,

All work has been done prior to B.C. being issued. P.S. received from S. Millson

INSPECTOR: J.I.F	DATE: 19/12/95
-------------------------	-----------------------

OTHER

OFFICER:	DATE:
----------	-------



ADVICE OF COMPLETION OF BUILDING WORK
Section 43(1), Building Act 1991

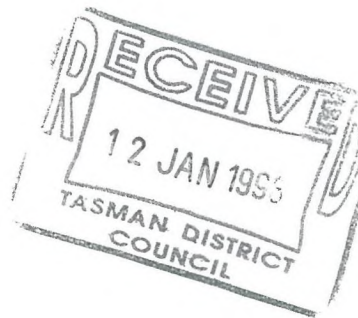

To: TASMAN DISTRICT COUNCIL

Under Building Consent No.: 951888

From: NICK HERRON
P O BOX 980
NELSON

Project location: BARNETT AVE, BEST ISLAND
Valn No.: 1938093400

Project descrn: ALTERATIONS, REPAIRS or EXTENSIONS
BEING STAGE 1 OF AN INTENDED 1 STAGES
EXTENSION OF KITCHEN AND RECLADDING OF HOME ✓

Intended life: INDEFINITE, BUT NOT LESS THAN 50 YEARS
Intended uses: RECLADDING AND KITCHEN EXTENSION

You are hereby advised that

FILE

- All
- Part only as specified in the attached particulars

of the building work under the above building consent is believed to have been completed to the extent required by that building consent.

You are requested to issue

- A final
- An interim

code compliance certificate accordingly (except where a code compliance certificate has been issued by a building certifier as stated below).

Please have the tradesmen (as applicable) associated with the building work sign the reverse of this form before returning to Council.

The attached particulars include:

- Building certificates
- A code compliance certificate issued by a building certifier
- Producer statements

Signed by or for and on behalf of the owner:

Name: [Signature]

Position: OWNER Date: 11-1-95

Business hours contact phone no.: 5441709

[Signature]

15/1/95

Done Prior to
ISSUE
But Looks OK.
[Signature]

Walterton.

~~Plasterers~~

Steve Millson Plumbing
Cory

Bill Scott.

CARPENTRY.

STOKE LAW CENTRE

Brian C Rowell LL.B. Principal Belinda Rowell (NZLEC) Legal Executive
Grant Parker B.Sc., LL.B. Staff Solicitor
Geoff Bracefield B.Com., LL.B. Staff Solicitor

9 January 1996

Tasman District Council
Private Bag 4
RICHMOND



ATTENTION: BUILDING CONSENTS

We act for Mr and Mrs Hawkins who are purchasing tomorrow a property owned by Nicholas Alan Herron at Bests Island, legal description Lot 36 Deposited Plan 5090, Certificate of Title 125/115. We know that the house has had major structural work done to it without building permits. We understand that Mr Herron has recently arranged to have Tasman District Council Building Inspectors inspect the property. Please confirm that the Tasman District Council has no outstanding requisitions/orders in respect of the property and forward by fax copies of any recent reports and certification. Understandably our clients do not wish to purchase a property which requires immediate expenditure to comply with the Building Act/Code.

Yours faithfully

BRIAN ROWELL

adbr:00043014

FAXED

FACSIMILE

TO: Brian Rowell
Stoke Law Centre.

FROM: Daryl Page

FAX NO: _____

DATE: 10/1/96

NO. OF PAGES 2
(including this)

IF YOU DO NOT RECEIVE ALL PAGES OF THIS TRANSMISSION PLEASE TELEPHONE IMMEDIATELY

Note: The information contained in this facsimile message is confidential to the intended recipient. If you have received this facsimile in error, please notify us immediately (by collect call if necessary) and destroy this facsimile. Any use distribution, dissemination or reproduction of this facsimile by any person other than the intended recipient is prohibited

Lot 36 Best Island - Hawkins purchase.
Your letter 9-1-96 refers.

The work you mention is covered by Building
Consent No 951888 issued 20/12/95.

After reviewing the work undertaken without
consent, Council decided to issue a building
consent under the Building Act due to
being "satisfied on reasonable grounds" that
work done complied to the Building code. This
was done by:

- Council inspection
- Engineer producer statement
- Plumbers producer statement.

A code compliance certificate was issued 21/12/95.

Property summary attached.

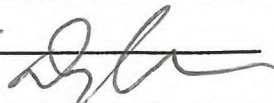
Regards

TDC Tasman District Council

Daryl Page
Consent Co-ordinator

DIRECT DIAL 5443425.