

NORTH ELEVATION

Scale 1:100

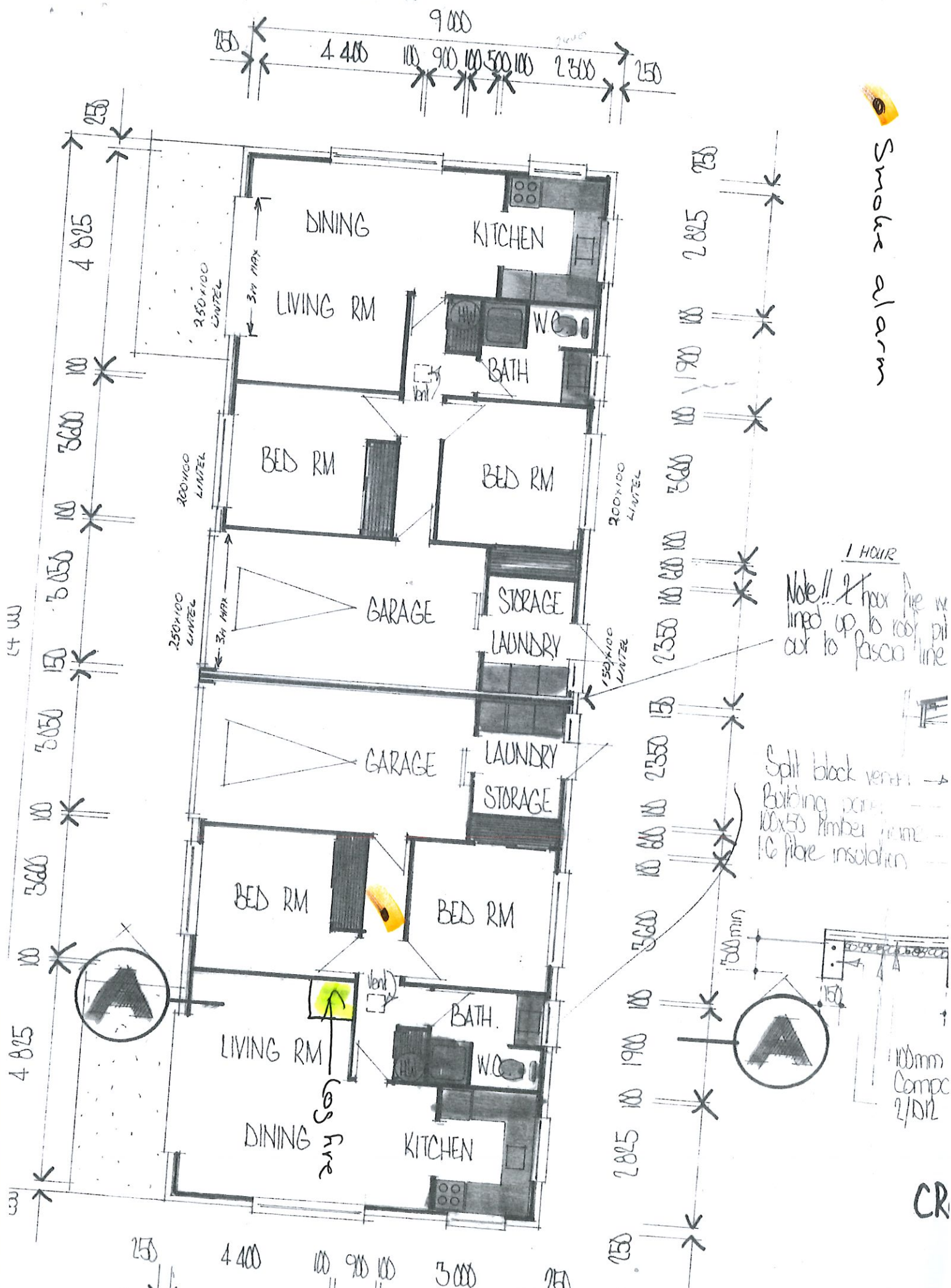

Smoke alarm

1 HOUR
Note!! 2 hour fire we lined up to roof pit cut to fascia line

Split block vents
Building frame
100x50 timber frame
10 fibre insulation

100mm Comp 2/10/12

CR

metrofires



NZ MADE WOOD FIRES

Tiny Ped

CLEAN AIR
 MODEL

 120m2

 11kW

 WETBACK

Designed to heat smaller homes and open areas. The Tiny Ped has the smallest footprint with corner and wall clearances of only 25mm and 60mm respectively. Featuring a surprisingly large 31 litre firebox for a compact wood fire. This fire punches well above its weight with a peak heat output of 11kW.

- Heat type:** Convection
- Heating area:** 120m2 / 2-3 bedroom home
- Finish:** High temperature paint finish
- Wetback:** ECO 2kW Booster
- ECan Authorisation #:** 073897 (DRY) 080009 (WET)
- Emission:** 0.72gms (DRY) 1.00gms (WET)
- Efficiency:** 78% (DRY) 66% (WET)



Fire only
\$1199

Add a Metro ECO Base Flue System and Pioneer Flue Shield for \$868

Prices are recommended retail and include GST

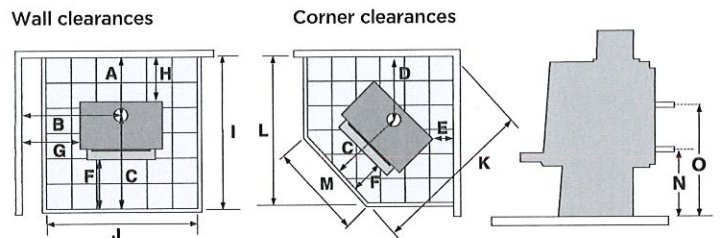

Clean Air Approved Model	Minimum installation clearances with a Pioneer double flue shield fitted													Wetback			Dimensions		
	A	B	C	D	E	F	G	H	I	J	K	L	M	N	O	Width	Depth	Height	
 Tiny Ped	210	430	580	290	25	200	185	60	790	650	990	875	250	280	470	490	530	665	

All details are correct and current at the time of printing. Specifications are subject to change without notification.



Clean Air Approved
Suitable for any size property. Can be installed into Clean Air Zones.



Heating Area m2
The floor area the Metro wood fire is capable of heating.
(Estimated on 2.4m stud height in an average NZ climate/insulation)



Kilowatt Output
Peak heat output with a Metro ECO Flue System fitted.
(A Metro ECO Flue System will increase overall heat efficiency in your home)



Optional Wetback
Can be fitted with an energy saving wetback to assist with your water heating requirements.

Wood Fire Installation & Owner's Operation Manual

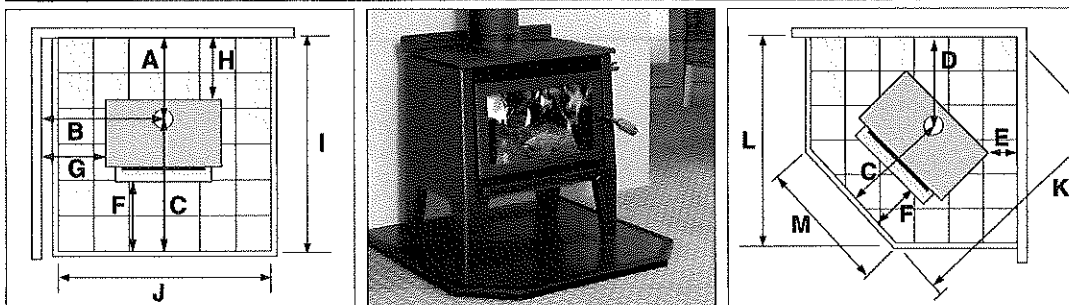
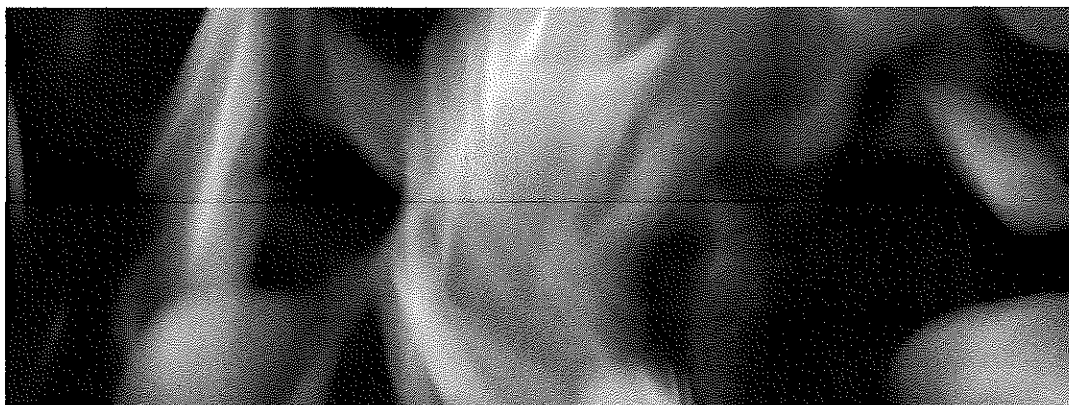

metrofires

Freestanding Wood Fires

Important information.....	2	Optional wetbacks.....	9
Assembling your Metro fire.....	2	Getting to know your Metro fire.....	10
Floor protector	4	Operating your Metro fire.....	10
Direct vent option.....	5	Cleaning and maintenance	11
Wetback and flue installation	6	Troubleshooting	12
Clearances and specifications	7	Metro Fires warranty	13
Important operation information	8	Replacement parts	14-15
Where to install a Metro fire in your home.....	9	Heating accessories.....	16

⚠️ WARNING! Important Information

- **WE HIGHLY RECOMMEND YOU READ THIS ENTIRE MANUAL AS INCORRECT OPERATION, MISUSE AND/OR LACK OF MAINTENANCE WILL VOID THE WARRANTY**
- The appliance and flue-system shall be installed in accordance with AS/NZS2918 and the appropriate requirements of the relevant building code or codes
- Any modification of the appliance that has not been approved in writing by the testing authority is considered to be in breach of the approval granted for compliance with AS/NZS4013 and will void the warranty
- The appliance must be installed correctly. We recommend a competent and suitably qualified NZHHA installer

⚠️ CAUTION! Important Information

- Mixing of appliance or flue-system components from different sources or modifying the dimensional specification or components may result in hazardous conditions. Where such action is considered, the manufacturer should be consulted in the first instance
- Do not install a Metro fire if there is any sign of visible damage to the product
- This appliance must be regularly maintained.
- Use authorised Metro replacement parts only. The use of unauthorised parts may void the warranty
- This manual **MUST** be left with the home owner

All Metro wood fires comply with AS/NZS2918:2001 when installed in accordance with this manual. Please ensure you are fully conversant with the relevant standard and the contents of this manual. Correct installation is critical to the safe operation and performance of this wood fire.

Please take particular note of the following:

- It is recommended that Metro fires be installed with a Metro ECO flue system which has been developed to enhance the performance of Metro wood fires. Any alternative flue system must have a minimum flue pipe length of 4.2 metres of 150mm diameter flue pipe & have been tested to AS/NZS2918:2001
- The 150mm active flue pipe must be fully encased from the ceiling to the underside of the flashing cone at the top of the flue system, (i.e. there must not be any 150mm flue pipe exposed)
- All flue pipe joints must be sealed and riveted. The bottom of the flue pipe in particular **MUST** be fully sealed into the flue outlet of the Metro fire
- In New Zealand, the Metro fire must be bolted through the floor protector into the floor to comply with the seismic restraint provisions of AS/NZS2918:2001
- All Metro's are extremely heavy, varying in weight from 75kgs up to 185kgs. During the installation process do not lift the appliance by yourself, and take care not to damage the panel coating
- Please take care when lifting the Metro fire into place onto the hearth or floor protector as point loading may break tiles and/or scratch surfaces.

Assembling your Metro wood fire

Please note: You should only assemble this wood fire if you are suitably experienced in wood fire assembly and installation. The Metro carton shows the model Metro you are about to install, enabling you to select the appropriate model's assembly instructions.

All Metro wood fires are packed in a single heavy-duty carton, and tek screwed to a wooden pallet. Having removed the packaging and located this manual, familiarise yourself with the illustrations on pages 2 & 3, and proceed as follows.

Metro radiant fires

These Metro's are supplied virtually fully assembled. Packed inside the firebox you will find bricks in a cardboard wrapper, a wire door handle and the air control wire handle.

- Remove the two tek screws located at the base of each rear leg which secure the Metro to the wooden pallet, and carefully 'walk' the Metro off the pallet
- Open the door fully and fit the side bricks to each side of the firebox. Location lugs are fitted to the base and rear wall of the firebox to retain the side bricks in position. Refer to Diagram 2
- Attach the door handle to the door latch assembly by screwing it on clockwise
- Attach the air control wire handle by screwing it on clockwise.

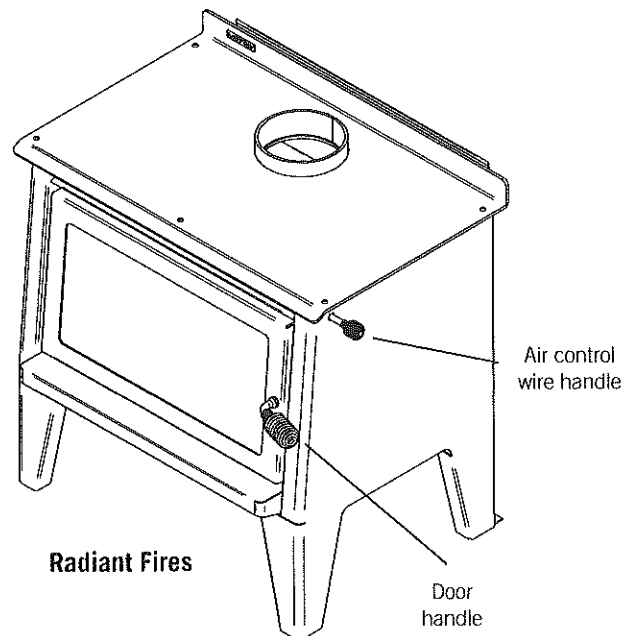

Assembling your Metro wood fire

Please note: You should only assemble this wood fire if you are suitably experienced in wood fire assembly and installation.

Metro pedestal and base model fires

To eliminate freight damage, the pedestal base has been packaged inside the firebox. To safely assemble your Metro, please proceed as follows:

- Lift off the top grill (convection models only) and place somewhere safe. Be careful not to chip the enamel coating or damage paint
- Open the door 45 degrees and lift the door off the hinge and place somewhere safe. Be careful not to damage the finish
- Remove the pedestal packed in a cardboard wrap
- Remove the pedestal mount plate

Note: The ECO Tiny Ped model utilises a slightly different pedestal to that detailed in Diagram 1. The rear panel on the pedestal must be turned around with the return fold facing back the opposite way. This then creates the mounting plate.

- Remove the pedestal heat shield

Note: For some models the pedestal heat shield may be taped to the rear heat shield. The ECO Tiny Ped's pedestal heat shield is pre-fitted.

- Remove the side bricks, door handle and the bolt bag
- Remove the 2 tek screws at the base of the inside of the firebox that fix the wood fire to the pallet.

It is recommended that 2 people work together with the next step:

- Grab the underneath top of the firebox door opening with one hand, holding the flue spigot with the other, slowly lift the front of the wood fire all the way back and rest the wood fire on its rear heat shield on the floor. Remove the packaging pallet.
- Fit the pedestal heat shield over the 4 bolts as shown in Diagram 1, with the open edge facing the front of the Metro (up)
- Position the pedestal with its front facing over the 4 bolts and fit the washers and nuts supplied, check to ensure the pedestal is correctly aligned and securely tighten the nuts.

It is recommended that 2 people work together with the next step:

- Grab the flue spigot with one hand and the other hand underneath the top of the firebox door opening, lift upwards standing the wood fire onto its pedestal
- Fit the side bricks to each side of the fire box. Location lugs are fitted to the base and rear wall of the firebox to retain the side bricks in position. Refer to Diagram 2
- Re-fit the door and top grill (Convection models only)

All Metro models

Check to ensure the top baffle is in its correct position in the top chamber of the firebox. It should be resting on four support lugs (two on each side of the firebox). The baffle must be hard back against the rear of the firebox with the "promet extension" (white board) or return front steel edge of the baffle facing forward as illustrated in Diagram 2.

Note: Some models feature a two-piece top baffle.

Diagram 1

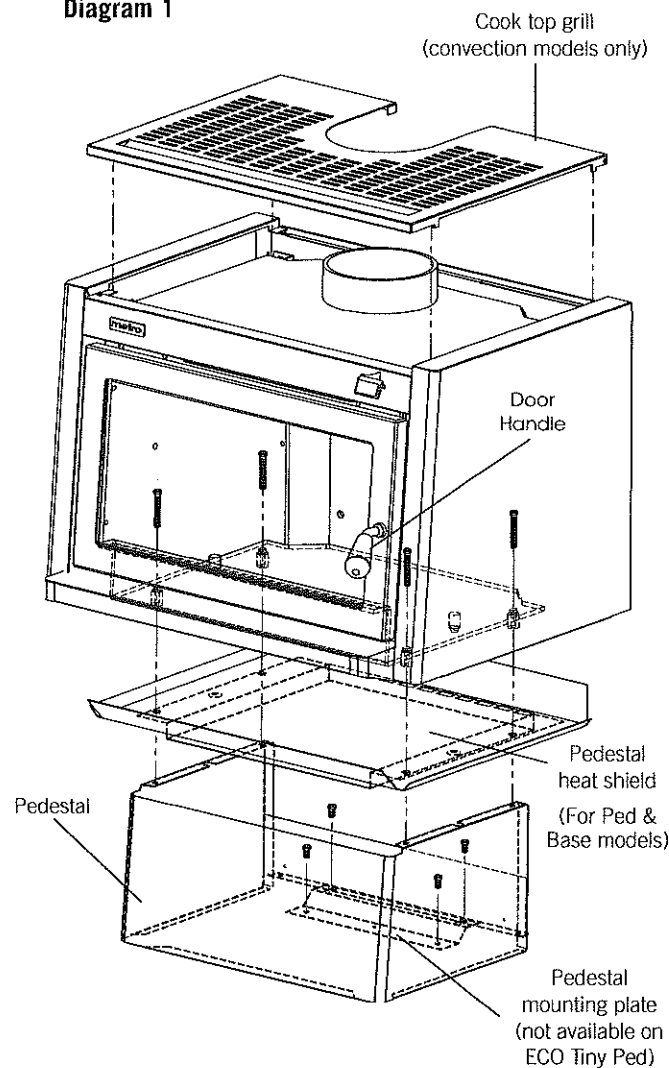
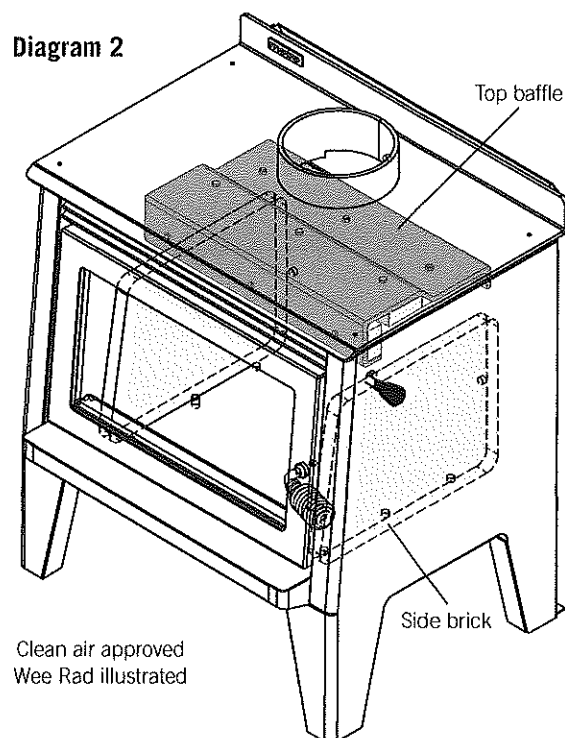

Diagram 2



Floor protector size, construction and fitting

Pioneer manufacture an extensive range of Pioneer 'Ash Floor Protectors' which comply with the minimum floor protector requirements of AS/NZS2918:2001, and can be installed with any freestanding Metro wood fire. Metro freestanding wood fires do not require an insulated floor protector as they comply with the minimum floor protector requirements of AS/NZS2918:2001. These minimum floor protector requirements are;

- They must be of adequate size to give appropriate wall, rear and front clearances/projections as detailed below and in the chart illustrated on page 7. Note;
- The floor protector must extend 200mm horizontally to the rear and each side directly below the door opening, and 300mm forward of the door opening
- The upper surface of the floor protector must be made of non-combustible material.

A suitable floor protector for a Metro freestanding wood fire is therefore any non-combustible material which could include;

- Ceramic tiles with grouted joints fixed directly to a hard base over timber flooring
- A sheet of toughened glass, panel steel etc. laid directly onto a wooden or other combustible floor.

Metro radiant fires

Lift the Metro fire onto the floor protector and using a suitable measuring device, ensure that the minimum wall clearances and front floor protector projections as detailed in the chart on page 7 are met or exceeded. Once the Metro's location on the floor protector is established and if the installation is within New Zealand, seismic restraint is required.

Using masonry anchors if the floor protector is on a concrete floor or coach bolts if a wooden floor, secure through the holes provided at the base, behind both rear legs.

Note: The anchors must pass through the floor protector and securely anchor the Metro to the floor.

Metro pedestal and base model fires

Lift the Metro fire onto the floor protector and using a suitable measuring device, ensure that the minimum wall clearances and front floor protector projections as detailed in the chart on page 7 are met or exceeded.

These models (excluding the ECO Tiny Ped) are supplied with a 'pedestal mounting plate'. Refer to Diagram 3. Once the location of this mounting plate is established, mark the seismic restraint points and shuffle the fire forward to allow securing of the mount plate through the floor protector into the floor using both of the two holes provided.

Use masonry anchors if the floor protector is on a concrete floor or coach bolts if a wooden floor. The fire can then be shuffled back into position and attached to the fixed mounting plate using the two M6 x12 bolts supplied.

Note: The anchors must pass through the floor protector and securely anchor the Metro to the floor.

Alternative Metro Mount Plate Installation

For installations when cosmetics of the mounting plate are not an issue, it is possible to 'invert' the mounting plate and use it as a means of bolting the Metro directly to the floor, through the floor protector. Refer to Diagram 3A and note;

1. Rotate the mount plate 180 degrees.
2. Secure the mount plate to the wood fires pedestal/base using the two M6 x12 bolts supplied.

You can then secure the Metro through the floor protector into the floor using the two seismic restraint holes in the rear edge of the mount plate. Use masonry anchors if the floor protector is on a concrete floor or coach bolts if a wooden floor.

Standard installation

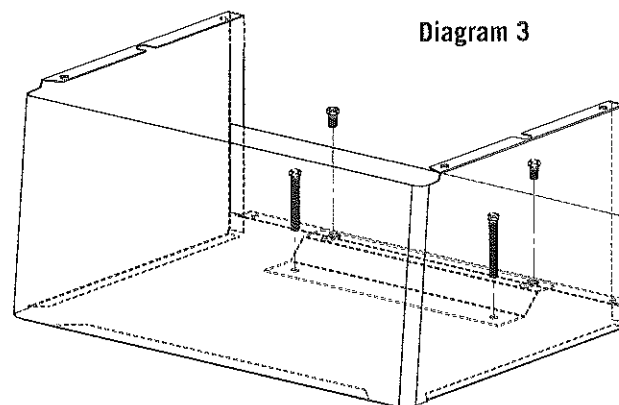

Diagram 3

Alternative installation

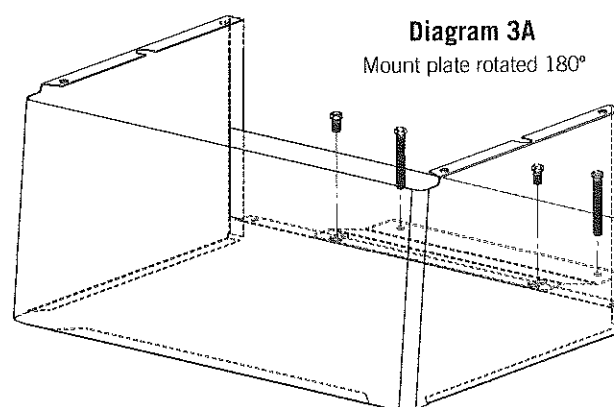

Diagram 3A
Mount plate rotated 180°

Flue installation

It is recommended that all Metro freestanding wood fires be installed with the energy efficient Metro ECO flue system which comes complete with a detailed installation manual. This installation manual must be presented with your application to gain consent with your local council.

A copy of the ECO Flue Systems installation manual can be downloaded from metrofires.co.nz, or a copy can be obtained from your Metro retailer. Any alternative flue system must comply with and be installed as detailed in AS/NZS2918:2001, and a copy of the installation manual must also be presented with your application to gain consent with your local council.

All Metro fires require a 150mm diameter flue. Please note:

- Metro ECO Flue Systems must be installed to allow unrestricted air supply from either the ceiling cavity for an ECO Base Flue Kit, or above the roof line if the Base & Option Kits are both installed
- The ECO Base Flue system must be installed into a 'vented' flat ceiling cavity, or have an ECO Option Kit added to the flue system to provide an external air supply

- Metro ECO Flue Systems shall be installed in accordance with AS/NZS2918:2001 and the appropriate requirements of the relevant building codes
- Any modification to this flue system that has not been approved in writing by the testing authority is considered to be in breach of all approvals granted
- The flue systems 150mm diameter flue pipe must terminate a minimum of 4.6 metres above the top surface of the floor protector
- All joints in the flue pipe must be sealed with Pioneer fire cement (or similar) and riveted. The base of the flue pipe must also be sealed into the Metro fires flue outlet. This is critical for optimum operation.

All Metro fires have been tested with a Pioneer double flue shield. For the Metro fire to be installed with minimal clearances as the clearance table on page 7 states, only the Pioneer double flue shield can be used. All other flue shields will invalidate the installation.

Direct vent option

The ECO Euro Ped has the option to be installed as 'Direct Vent' appliance, drawing all primary and secondary combustion air from outside the home. Once connected, this venting option ensures the air that is heated within the home, stays in the home improving efficiency and reducing fuel usage.

Note: Connection of the Metro's direct vent inlet to outside the home is optional. If not connected this Direct Vent model still offers greatly improved performance and lower emissions due to the unique pre-heated air path for all primary and secondary combustion air that this model consumes.

Direct Vent Options

Three Direct Vent kits are available to connect the ECO DV Metro to an air supply from outside the home. The kits available include;

- DV WALL KIT – For installations when the Metro fire is installed against an outside wall
- DV FLOOR KIT – For installations onto a floor which has a free air supply below it
- DV CEILING KIT – For installations when the Metro fire is installed against an internal wall and on a concrete floor. The DV Ceiling kit goes into the wall cavity, up inside the wall into the ceiling cavity, where the air supply is drawn from.

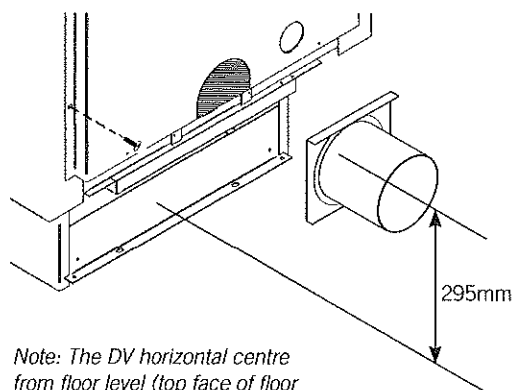

Note: The DV horizontal centre from floor level (top face of floor protector/hearth) is 295mm

Installing the Direct Vent Option

Remove the rear heatshield from the Metro wood fire by unscrewing the four self-tapping screws illustrated in Diagram 4 and proceed as follows;

1. Remove the section of panel illustrated with a 'hatch', from the mid/ bottom section of the rear heatshield. This section to be removed has been pre-punched and only requires a few small tabs to be cut.
2. Take the 'inlet spigot' supplied in the Direct Vent kit and slide it fully down into position into the brackets provided on the rear of the firebox.
3. Re-fit the Metro's rear heatshield with the four screws.

The Metro wood fire is now ready for installation once you have pre-fitted the Direct Vent kit into the wall or floor. Full instructions for this procedure are supplied with the Direct Vent kits.

Diagram 4

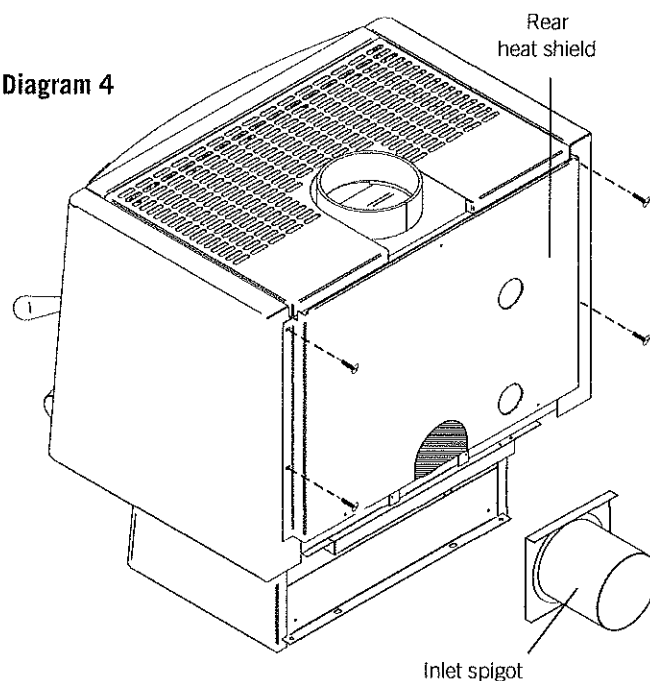

Wetback installation

WARNING! Important Information

- DO NOT connect to an unvented hot water system
- Install in accordance with AS 3500.4.1 or NZS 4603 and the appropriate requirements of the relevant building code or codes.

CAUTION! Important Information

- Wetbacks must be connected with water before operating the fire and available to the wetback while the fire is in operation
- Wetback systems are not suitable for use in locations where the water supply has lime content. Lime build up inside the coil will eventually block the coil causing the wetback to fail
- Rainwater collection tanks installed lower than the wetback that use a water pump to supply the home, can cause problems if the pump is not operational. In these situations either the type of wetback or a roof header tank should be considered

Water heating is another key feature of your Metro wood fire; nearly all Metro models can be fitted with a wetback, which are designed to give maximum output with minimal effect on the operation of the fire. Only the Pioneer cast jacket wetback system should be fitted to your Metro; alternative wetbacks will void the Metro's emission approvals and may seriously affect the performance of the appliance and void its warranty.

Wetback connections are as follows, taken facing the Metro/wall; the return pipe connection is directly above the inlet connection. Heights for all models are illustrated and detailed opposite on page 7.

- ECO Tiny Ped and ECO Tiny Rad models are 92mm left of the flue centre
- The Tiny Rad Woody model is 184mm left of the flue centre
- Wee Series models are 226mm left of the flue centre
- The Classic Rad model is 184mm left of the flue centre
- All other models are 140mm left of the flue centre

All wetbacks are fitted to the inside rear wall of the firebox, with the exception of the Tiny Rad Woody, clean air Wee Series models and the Classic Rad model. Side wetback position for these models is to the outside left hand firebox wall. Please see the specific installation instructions in the 'Side Wetback' box for installation of a wetback into these appliances.

It is recommended the return pipe has a minimum rise of 1 in 12; performance will reduce as the distance to the storage cylinder increases.

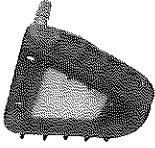
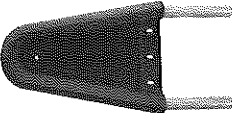
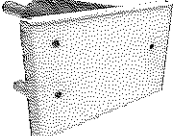
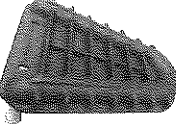
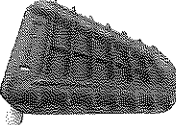
Wetback	Suitable for models:
2kW Wetback 	<ul style="list-style-type: none"> • ECO Tiny Rad • ECO Tiny Ped
Side Wetback 	<ul style="list-style-type: none"> • Tiny Rad Woody • Wee Rad & Wee Rad Base • Wee Rad Woody • Wee Ped • Classic Rad
ECO Wetback 	<ul style="list-style-type: none"> • ECO Euro Ped
3kW Wetback 	<ul style="list-style-type: none"> • Xtreme Rad & Xtreme Rad Base • Xtreme Rad Woody • Xtreme Ped • Mega Rad • All LTD rural models
4kW Wetback 	<ul style="list-style-type: none"> • All LTD rural models

To fit the wetback proceed as follows

1. Remove the rear panel of the Metro by removing the four pozi drive screws. Remove the two pre-punched knockouts from this panel.
 2. Two further knockouts will be visible on the inner rear heatshield, remove these also. Once these are removed 6mm nuts will be visible through the knockout holes.
 3. Open the Metro's door and locate two bolts securing the pressed washers which are visible on the left hand side of the firebox for both inlet and outlet connection points.
 4. A further three bolt heads will also be visible on the inside rear wall of the firebox; these are threaded into the 6mm thick firebox. Remove all three.
 5. Using the tube of sealant supplied with the wetback, apply a liberal bead of sealant around both the two connection pipes and also the outer circumference of the wetback which will face and press against the inside rear wall of the firebox. This will completely seal the wetback to the inside rear wall of the fire on installation.
- Ensure there is no gap between pipe and rear wall access holes. This cement must fully cure before appliance use.
6. Fit the wetback into the firebox and carefully pass the connection pipes through the holes in the rear of the firebox. Securely attach the wetback using the three bolts previously removed from the rear face of the firebox, fitting them through the slots provided in the wetback's jacket.
 7. The wetback is now ready for connection to the storage cylinder by a registered plumber.

The R1 and R2 models cannot be fitted with a wetback.

Metro clearances and specifications (Minimum clearances shown are in mm, with a Pioneer double flue shield fitted)

Minimum clearances

All Metro wood fires comply with AS/NZS2918:2001. Minimum clearances shown below are detailed in millimetres, with a Pioneer double flue shield fitted to the appliance. Measurements are taken from the following reference points as illustrated:

- From the nearest combustible wall or surface (A, B, D, E, G, H)
- From the Metro's flue centre (A, B, C, D)
- From the Metro's cabinet/heatshield outermost point (E, F, G, H)
- To the edge of the ash floor protectors non-combustible surface (C, F, I, J, K, L, M)

AS/NZS2918:2001 allows for a reduction in minimum clearances as detailed in Section 3, tables 3.1 and 3.2 of the standard.

Some Metro models have undergone additional testing which allows for reduced clearances. Please see the footnotes below the clearance table for the applicable models.

Wetback connections (taken facing the Metro/wall)

- ECO Tiny Ped and ECO Tiny Rad models are 92mm left of the flue centre
- The Tiny Rad Woody model is 184mm left of the flue centre
- Wee Series models are 226mm left of the flue centre
- The Classic Rad model is 184mm left of the flue centre
- All other models are 140mm left of the flue centre

Specifications were correct at the time of printing, but may alter and those detailed within should be used only as a guide. If in doubt, please consult your Metro retailer or metrofires.co.nz.

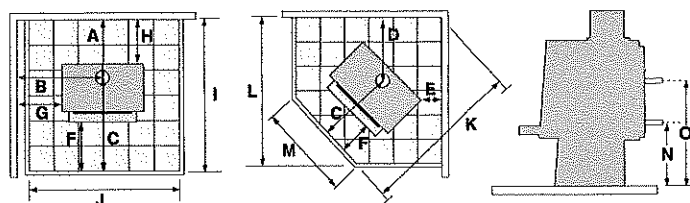

Clean air models	Minimum installation clearances with a Pioneer double flueshield fitted (mm)															Wetback		Dimensions	
	A	B	C	D	E	F	G	H	I	J	K	L	M	N	O	Width	Depth	Height	
ECO Tiny Ped	210	430	580	290	25	200	185	60	790	650	990	875	250	280	470	490	530	665	
ECO Tiny Rad	225	552	580	420	150	200	300	75	805	650	1165	925	250	280	470	505	530	665	
Tiny Rad Woody	251	568	580	382	110	230	310	100	831	650	1120	880	250	365	555	515	498	758	
R1	243	774	586	554	280	244	530	100	829	825	1370	1118	425	N/A	N/A	488	485	668	
R2	246	858	626	582	275	235	570	100	872	905	1449	1203	505	N/A	N/A	575	537	690	
Wee Rad ¹	251	568	580	455	150	230	260	100	831	825	1224	1015	425	295	485	615	501	688	
Wee Rad Base	271	678	580	489	180	230	370	120	851	825	1270	1049	425	295	485	615	501	691	
Wee Rad Woody	271	708	580	509	200	230	400	120	851	825	1285	1069	425	365	555	615	501	758	
Wee Ped ²	263	651	580	490	170	230	350	110	843	825	1274	1050	425	295	485	602	503	665	
Classic Rad ³	257	695	780	500	220	229	430	100	1037	728	1487	1168	328	393	583	530	707	680	
Xtreme Ped	251	624	630	441	110	227	280	100	881	907	1254	1065	507	312	502	688	554	721	
Xtreme Rad	251	650	630	458	100	227	280	100	881	907	1277	1077	507	312	502	740	554	743	
Xtreme Rad Base	251	650	630	458	100	227	280	100	881	907	1277	1077	507	312	502	740	554	743	
Xtreme Rad Woody	251	680	630	478	120	227	310	100	881	907	1292	1097	507	382	572	740	554	813	
ECO Euro Ped DV ⁴	230	585	625	495	170	200	250	80	855	905	1325	1120	505	325	515	670	575	715	
Mega Rad	285	720	728	497	100	224	300	130	1013	1006	1431	1227	606	300	490	840	659	744	
LTD rural models	A	B	C	D	E	F	G	H	I	J	K	L	M	N	O	Width	Depth	Height	
LTD Wee Rad	251	548	580	425	120	230	240	100	831	825	1180	985	425	295	485	615	501	688	
LTD Wee Rad Base	251	658	580	489	180	230	350	100	831	825	1270	1049	425	300	490	615	501	691	
LTD Wee Rad Woody	271	708	580	509	200	230	400	120	851	825	1285	1069	425	360	550	615	501	758	
LTD Xtreme Rad	251	650	630	458	100	227	280	100	881	907	1277	1081	507	350	540	740	554	743	
LTD Xtreme Rad Base	251	650	630	458	100	227	280	100	881	907	1277	1081	507	350	540	740	554	743	
LTD Xtreme Rad Woody	251	680	630	478	120	227	310	100	881	907	1292	1097	507	420	610	740	554	813	
LTD Mega Rad	285	720	728	497	100	224	300	130	1013	1006	1431	1227	606	300	490	840	659	744	

The Wee Rad installed with a Pioneer double flue shield with the Wee Rad corner wing shields fitted allows for reduced clearances as follows:

¹ Wee Rad corner clearance (E) can be reduced to 120mm. This in turn also reduces clearances (D) to 425mm, (K) to 1180mm and (L) to 985mm. When fitting the corner wing shields, the Wee Rad itself must be installed to a corner clearance (E) of 120mm. The corner wing shields are then fitted which gives a wall to shield corner clearance of 100mm.

The following models installed with a Pioneer double flue shield with the side extensions fitted allows for reduced clearances as follows:

² Wee Ped corner clearance (E) can be reduced to 115mm. This in turn also reduces clearances (D) to 436mm, (K) to 1197mm and (L) to 996mm.

³ Classic Rad corner clearance (E) can be reduced to 180mm. This in turn also reduces clearances (D) to 460mm, (K) to 1430mm and (L) to 1127mm.

⁴ ECO Euro Ped corner clearance (E) can be reduced to 110mm. This in turn also reduces clearances (D) to 435mm, (K) to 1240mm and (L) to 1060mm.

WARNING! Important Information

• **WE HIGHLY RECOMMEND YOU READ THIS ENTIRE MANUAL AS INCORRECT OPERATION, MISUSE AND/OR LACK OF MAINTENANCE WILL VOID THE WARRANTY**

- Any modification of the appliance that has not been approved in writing by the testing authority is considered as breaching AS/NZS 4013 and will void the warranty
- Do not use flammable liquids or aerosols in the vicinity of this appliance when it is operating
- Never operate your Metro with the top grill removed
- Do not dry clothes on or near this appliance
- Do not use flammable liquids or aerosols to start or rekindle the fire OR store fuel within the Metro's specified installation clearances
- Never operate your Metro with the door ajar, except on initial start up
- Open the air control fully before opening the Metro's door.

CAUTION! Important Information

- This appliance should be maintained & operated at all times in accordance with this instruction manual
- This appliance should not be operated with cracked door glass, over worn, faulty or missing door seals
- Do not use driftwood, treated or unseasoned (wet) fuel, the use of most types of preservative treated wood as fuel can be hazardous and will damage your appliance
- Burning unseasoned (wet) fuel or incorrect operation on extended low burn cycles will cause excessive creosote to form. Creosote is very corrosive and excessive buildups will result in the flue pipe, flue spigot and upper burn chamber failing. Failure of the appliance and/or flue system due to creosote damage is not covered under warranty. The formation of such is not an appliance issue it is a fuel and operational issue
- This appliance must be regularly maintained and replacement parts must be authorised Metro parts only
- Do not empty ash into a combustible container.

Congratulations on the purchase of your Metro wood fire

This slow combustion appliance is designed to give you many years of warmth and service, subject to the following key factors. These key factors, if not adhered to are the major causes of unsafe installation, poor performance and flue blockages and potential product failure.

1. Your Metro wood fire must be installed correctly. Metro recommend a competent and suitably qualified NZHHA installer.
2. The only fuel to be used in this appliance shall be wood that meets the following criteria.
 - Less than 25% moisture content
 - Has not been treated with preservatives or impregnated with chemicals or glue,
 - Is not chipboard, particle board, or laminated board,
 - Is not painted, stained or oiled
 - Is not driftwood or other salt impregnated wood
3. The appliance shall be operated at all times in accordance with the "Installation and Operating Instructions" supplied with each appliance.
4. It is preferable that Metro wood fires should be installed with a Metro ECO Flue System.
5. Coal must not be used as a fuel.

Please also note the following important points:

- In New Zealand a building consent is required from your local building authority. The homeowner is responsible for obtaining this consent
- As correct installation is critical to the performance and safe operation of your Metro, it is recommended your Metro be installed by a NZHHA registered installer or a person suitably qualified in the installation of wood fires. Your Metro retailer will be able to arrange professional installation for you
- During the very first fire your Metro will give off an odour and fumes as the firebox paint cures. Do not be alarmed; open all windows and externally opening doors in that room and close any internally opening doors. This curing process will last for approximately one hour and is likely to happen this one time

- Properly seasoned (dry) timber is necessary for the Metro to operate efficiently; firewood that contains a high moisture content will result in flue pipe blockages, reduce heat output and create other issues.

Note: Once split, Softwood usually takes 12 months to season - Hardwood can take up to 24 months to season - Wood must be stored in a location that enables air circulation. Unseasoned wood stored in a closed woodshed without air circulation will still be unseasoned 12 months later.

- It is critical that the fire not be operated with over worn, faulty or missing door seals. Door seals will harden over time and become over-worn (3-4 year's) this will cause air to leak into the fire, causing the appliance to 'over fire'
- It is critical that the fire not be operated with over worn, faulty or missing bricks, baffle plate, promet extension (white board on the baffle plate)
- It is critical that the fire not be operated with cracked or broken door glass.

Please note, the above 3 points require regular inspection/maintenance (every time the ash bed is cleaned out, generally 3-5 times a season) and if not maintained will void the firebox warranty. A glowing firebox or lower fluepipe is just one sign you are over firing your appliance. Please ensure you keep your proof of purchase/receipt on any parts you purchase.

- For optimum performance fuel must be loaded so the logs lay "front to rear" in preference to laying across the width of the firebox. Spaces should be left between the logs to enable oxygen to get to as much of the surface of the fuel as possible
- A small hot fire loaded frequently is more efficient than a large fire burning on a low setting
- Your Metro is covered by a full unconditional 12 month warranty on replacement parts, and a 10 year firebox warranty.

Where to install a Metro wood fire in your home

Wood fires are usually installed in the main living area, which is the section of the home that is usually kept the warmest, being the area in the home most frequently occupied. However, before deciding on the best location for your Metro wood fire you may wish to consider:

- Water heating. If you are intending to have a wetback it is important that the wood fire is as close as practically possible to the water storage cylinder
- Split level homes are best heated when the wood fire is installed on the lower level, as the heated air will rise to the higher levels
- Building construction is another consideration. Specified clearances from walls, curtains etc must be maintained and you need to ensure no structural beams or internal gutters etc are directly above your preferred site. If you have a two storey dwelling you need to consider the second storey to ensure you don't have the flue directly outside a second storey window.

Generally, you can install your Metro in your home anywhere that suits you; Pioneer offer various fan systems to transfer heat to other sections of the home that are not heated sufficiently. It is necessary if using a fan system that the Metro you have purchased has sufficient output to heat the total area you wish to heat. Your Metro retailer or installer will be able to advise if you are uncertain.

Optional wetbacks

Water heating is another key feature of your Metro wood fire; nearly all Metro models can be fitted with a wetback, which are designed to give maximum output with minimal effect on the operation of the fire. Only the Pioneer cast jacket wetback system should be fitted to your Metro; alternative wetbacks will void the Metro's emission approvals and may seriously affect the performance of the appliance and void its warranty.

Other considerations are:

- Distance from your Metro to the storage cylinder will affect the amount of hot water produced
- Your climate & the manner in which you will 'fire' your Metro will determine the amount of hot water produced.



Note: Wetbacks are not suitable for use in locations where the water supply has lime content. Lime build up inside the coil will eventually block the coil causing the wetback to fail.

Cost Savings

Wetbacks can enable substantial power savings, dependent on the climate in the area in which you live. If you live in a cold climate you are likely to use your Metro for many months of the year, in which case a Pioneer wetback will reduce or even eliminate your water heating costs over those months. If however you live in a warmer climate and use your Metro for only a few hours a day over the colder months, electricity savings will be considerably less.

Water Pressure

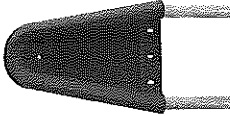
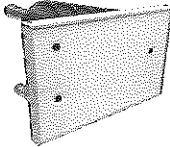
A common misconception is that you must have a low-pressure system to have a wetback; this is not true. You must have a 'vented' system and high-pressure cylinders are usually not vented. However you can install an 'indirect' cylinder which contains a secondary coil inside the storage cylinder, enabling you to have a wetback while retaining a high-pressure system.

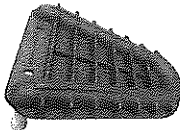
Wetback	Suitable for models:
2kW Wetback 	<ul style="list-style-type: none"> • ECO Tiny Rad • ECO Tiny Ped
Side Wetback 	<ul style="list-style-type: none"> • Tiny Rad Woody • Wee Rad & Wee Rad Base • Wee Rad Woody • Wee Ped • Classic Rad
ECO Wetback 	<ul style="list-style-type: none"> • ECO Euro Ped
3kW Wetback 	<ul style="list-style-type: none"> • Xtreme Rad & Xtreme Rad Base • Xtreme Rad Woody • Xtreme Ped • Mega Rad • All LTD rural models
4kW Wetback 	<ul style="list-style-type: none"> • All LTD rural models

The R1 and R2 models cannot be fitted with a wetback.

Getting to know your Metro wood fire

Operating your Metro fire is simple and you will quickly learn how to get the best from it. First take a minute to familiarise yourself with your new Metro.

- Raise the door handle anti-clockwise until the latch releases, and then slowly pull the door open. You will note that if you let the door go before it is at 90° to the appliance, it will fall closed. This is a safety feature that ensures the door cannot fall open if it is not latched securely. For the door to remain open, you must open it fully
- There is a single air control making your Metro fire easy to adjust. This control moves from left to right, which is 'low to high'.

All Metro radiant fires have a wire air control handle located at the upper right hand side of the appliance. Simply pull out to increase burn rate or push in to reduce burn rate.

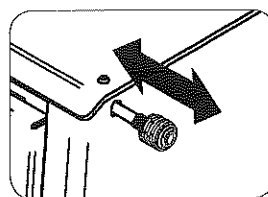

Radiant fires air control

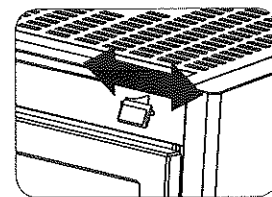

All other fires air control

All other Metro fires have an air control knob located on the upper front panel of the appliance.

Slide this control knob gently from right to left until you reach a stop. This is a pre-set 'low' position. Your Metro fire must not be operated at a lower burn rate than this pre-set low allows.

Operating your Metro wood fire

If your Metro has only been installed within the past few days, the fire cement seal at the base of the flue will not be fully cured. To ensure the cement sets without blistering it is recommended you burn 2-3 sheets of loosely crumpled newspaper at a time, approximately once every hour over a 6-8 hour period.

During the very first fire your Metro will give off an odour and fumes as the firebox paint cures. Do not be alarmed. Open all windows and externally opening doors in that room and close any internally opening doors. This curing process will last for approximately one hour and is likely to happen this one time.

Start up

Place a quantity of loosely crumpled newspaper on the base of the firebox until it is approximately half full of paper, or place firelighters on the base of the firebox. Add dry kindling and move the air control knob fully to the right, being the 'full open' position.

Light the paper at two or three locations across the front of the door opening and leave the door slightly ajar resting on the latch pin if necessary for a few minutes while the fire establishes. Once the kindling is burning well, open the door and add 2-3 small logs at a time until you have a well-established fire. Usually this will take approximately 30 minutes, during which time the air control should be set on "high" and the door should be closed, except for the initial few minutes and when fuel is being added.

Normal operation

Once the fire is well established, regulate the air control to achieve the desired burn rate and heat output. As you move the air control to the right, burn rate, firebox temperature and heat output will increase, if you move the control to the left they will decrease. Please note:

- Always open the air control fully prior to opening the door, then open the door slowly. Every time you refuel, leave the air control on 'high' for a minimum of 20-25 minutes
- When loading logs, place them end-on, 'front to back'; air spaces should be left between the logs to enable oxygen to get to as much of the surface of the fuel as possible
- Never use the door to force wood into the firebox, as this is likely to break the glass.

Extended burning (rural models only)

It is most important if your Metro is to be refuelled and turned down for an extended period, such as an overnight burn that you operate it correctly:

- The wood used as fuel for extended burning **MUST BE FULLY SEASONED (DRY)**. Once the fuel is loaded, the appliance must be operated on high for a period of at least 20 minutes to drive out residual moisture from the fuel (dry wood is usually 20% water content) and ensure surface area combustion.
- Do not turn the air control down lower than you need to, if you want the Metro to burn overnight, endeavour to obtain an 8 hour burn time, not 12 hours. It will take a few burns to find the correct location of your Metro's air control setting to achieve the length of burn cycle you desire as this setting is affected by several variables including fuel density, flue length and outside wind velocity.
- A smouldering fire over a long time frame is likely to deposit corrosive elements into your system which could be detrimental to your Metro.

CAUTION! Important Information

- If not operated correctly on extended burn cycles, your Metro is likely to incur flue blockages, corrosion of the upper baffle, lower flue pipe and firebox flue spigot. As these are not covered under warranty if they fail through improper use, it is important you operate your Metro correctly.

Cooking

All Metro's are designed to enable cooking of soups, stews and casseroles etc, and your Metro will easily boil a flat bottom stainless steel kettle. The Radiant Series have a dedicated cooking top enabling large pots to be placed on the cook top, while all other models have a lift-off grill.

Note: Metro's supplied with a lift-off top grill have this feature to enable the grill to be removed for cleaning if you have a spill. The lift-off top grill must be left on when cooking, because if removed the wall temperatures next to the appliance may become excessive and the top of the firebox is generally too hot to cook on directly.

Cleaning and maintenance for your Metro wood fire

Your Metro fire will give you many years of efficient service with minimal maintenance if operated correctly using seasoned fuel. Your Metro fire must be regularly maintained and replacement parts must be authorised Metro fires parts only.

The Metro radiant fires are painted wood fires and coated with 'Pioneer Metallic Black' high temperature paint and will require periodic repainting to keep them looking their best.

All other Metro fires are coated with vitreous enamel. Vitreous enamel is extremely durable and designed to last the life of the appliance. As vitreous enamel is glass, a solid or heavy object dropped or banged against a panel could chip the enamel surface.

All model Metro fires can be cleaned with a soft cloth when the appliance is not in operation.

Door glass

Providing your fuel is properly seasoned, under normal operating conditions the air-wash design of the Metro's firebox will keep the door glass clear. If the glass requires cleaning you may use either a razor blade scraper or crumpled wetted newspaper dipped in wood ash rubbed over the glass.

If your door glass breaks it must be replaced with 5mm thick ceramic glass which is available from your local Metro retailer.

Door seals

Over time, usually 3-4 years, the door and glass seals will become hard and cause air to leak into the firebox, causing the appliance to 'over fire'. Your Metro retailer stocks replacement woven fibreglass door and glass seals, which need replacing when they become hard and over worn.

The door of your Metro is easily removed. Hold it in both hands and lift the hinge end of the door up and over the top hinge pin, then lower the door from the bottom hinge pin.

Side bricks

Hair-line cracks are not uncommon and are a result of the intense heat within the Metro's firebox, coupled with mechanical damage caused by accidental impact when fuel is being loaded. However if the side bricks become cracked to the extent that they start to break up, they must be replaced.

Door adjustment

Provision is available on both sides of the door for adjustment.

To adjust the hinge end of the door, open the door fully, loosen the top hinge nut and slightly lift the latch end of the door; you will see the hinge assembly move back 1-2mm which will usually be sufficient. Retighten, then repeat by loosening the lower hinge nut, this time applying a slight downwards pressure onto the door to move the lower hinge assembly back a similar distance, then retighten.

The door latch is also adjustable, as the latch pin on the right side of the firebox is fitted through a slot which enables the latch pin to be loosened, moved back and re-tightened.

Ash removal

Over a period of time ash will build up in the base of the Metro's firebox and require removal. The time this build-up takes depends on the density and cleanliness of your fuel.

To remove the excess ash your Metro should not be operating.

- Open the door, and using a hearth shovel or similar, empty the excess ash directly into a steel or non-combustible container.
- If the ash is not disposed of immediately, be careful where you store it, as the ash can retain heat for many days and become a fire hazard.
- You must leave a bed of ash in the base of the firebox approximately 10mm deep; this insulates the base of the firebox and improves combustion.

Top baffle

This is a 'sacrificial' wear part of the firebox and should be checked monthly. Usually only the promet (white board) front/underneath section needs to be replaced when it starts to disintegrate.

Note: Cracks in the promet are not uncommon and have no adverse effect on the operation of your Metro. These cracks are the result of intense heat coupled with expansion and contraction. Burning wood which is not properly seasoned, i.e. 25% moisture content or more, will over time cause the promet to disintegrate and require replacement.

Flue systems

Should be checked annually, particularly the bottom end of the lower flue section at its rear lock formed joint. If deterioration is noticed contact your Metro retailer or installer.

The flue pipe should also be swept a minimum of once a year, or as required during the winter season. If smoke enters the room when you open the Metro's door this usually indicates the flue pipe is becoming restricted and needs cleaning. The frequency of flue pipe cleans depends on many factors, with the main variables being:

- The seasoning of the wood. If not properly seasoned you will require frequent flue pipe cleans.
- The density of the wood. Softwoods generally result in more deposits building up in the flue pipe.

To clean the flue pipe of your Metro, proceed as follows:-

- Open the Metro's door fully, reach inside with the palm of your hand face-up and extended, lift the top baffle approximately 20mm, then lift it forward out through the door opening, placing it on a sheet of newspaper you have placed on the front of the floor protector. To prevent jamming, removal and replacement of the top baffle is best performed using both hands.

Note: Some appliances have a two piece top baffle.

- Close the door and slide the air control to the left.
- Once on the roof, remove the cowl from the top of flue system and sweep the flue pipe using a 150mm-diameter flue pipe brush as detailed in the instructions provided with the fluebrush.
- Once the flue pipe is clear, clean and refit the cowl. Remove the excess soot which has fallen into the firebox, leaving a layer of ash 10mm deep on the base of the firebox, then refit the top baffle.

Note: The baffle must be fitted so its rear is touching the back of the firebox; if uncertain refer to page 3 in the installation section at the front of this manual, which shows illustrations of the baffle location.

Troubleshooting your Metro wood fire

If your Metro is installed correctly, your fuel is dry and you operate your fire correctly, you will find it to be a pleasure to use. Metro's many years of experience within the wood heating industry has shown that dissatisfaction is mainly due to:

- unseasoned fuel
- faulty installation
- operational error
- or a combination of the above 3 points.

Correct operation

Modern day wood fires need to be operated hard and fast, more so than low and lazy to ensure the firebox and flue pipe runs hot and efficiently. If the fire and flue pipe is up to temperature it will perform extremely well, the smoke will draw up the flue pipe with ease, and the fire will produce good amounts of heat.

If the fire is operated on low a lot of the time, the door glass will run black, the flue pipe will tend to block up more frequently and the fire will end up smoking into the room when reloading. It's better to have a small fire running hard and fast, rather than a big fire running low and lazy.

The following may be of assistance if you are experiencing any problems with the operation of your Metro Fire.

Smoke enters the room when the Metro's door is ajar

(possible reasons and solutions)

Check flue pipe joins

If the flue pipe joins are not sealed correctly, the flue pipe will not draw as well as it should. The flue pipe join connecting into the flue spigot on top of the Metro is most critical, if this is not sealed correctly, smoke will enter the room when the door is ajar. To check this join is sealed correctly, run a match or lighter flame around the join. If the flame is sucked into the spigot then it is not sealed correctly. This check needs to be done when the fire is not going. Ensure you check the rear of the flue pipe/spigot join, as due to the seam in the flue pipe, this is the most common area for not being sealed correctly.

Ensure the fuel you are using is correctly seasoned

If you are burning unseasoned fuel (wet), the fire will cause nothing but problems. The Metro won't deliver much heat, it will be lazy, smoke will enter the room when the door is ajar, and the door glass will run black. Unseasoned fuel is the main contributor to excessive creosote deposits which can be corrosive to your appliance and flue system.

Flue pipe length is too short

Add more flue pipe as the longer the flue system, the better the draw of the flue pipe. Please note, if you did not purchase the Metro ECO Flue System, you will not have the ECO Cowl which increases draw. We highly recommend the Metro ECO Cowl is fitted as this will increase the draw. If you already have an ECO Cowl and smoke is still entering the room, please add another 600mm length of flue pipe.

Downdraft/Turbulence blockage

If you have checked all of the previous factors and the fire is still smoking into the room, it's possible there may be a down draft issue. Down draft is environmental and can be caused by many variables, and it is purely trial and error to ascertain the cause.

Air turbulence and/or negative air pressure influences around the flue termination can be caused by too close or overhanging trees or natural/artificial ridges etc. Address these where possible or look to extend the flue above the roofline.

Other options may be:

- 'H' Cowl, designed purely for downdraft issues, but if you have an ECO Cowl fitted as standard, you will also need to add another 600mm of flue pipe to compensate as the H Cowl is shorter in length
- Directional Cowl, designed for high wind areas.

Air control setting

Ensure the air control setting is on high before opening the door to reload, as this increases the draw up the flue pipe. Open the door slowly.

If your Metro did not smoke, but its starting too and is getting worse:

The flue pipe is in need of a clean. It is recommended that the flue pipe be cleaned every season, however if you are burning the fire on low a lot, or are using unseasoned fuel, flue pipe cleans will be required more frequently.

Other issues you may experience

I can smell smoke in the room after a low burn cycle

The smell is creosote that will be seeping through the flue pipe join or out of the flue spigot onto an external surface, thus creating the smell in your room. The cause will be either unseasoned fuel, fuel mass too large, incorrect operation on low burn cycles or a combination. Creosote is very corrosive and excessive buildups will result in the flue pipe and potentially the flue spigot and upper burn chamber failing. The formation of excessive creosote is not an appliance issue, it is a fuel and operational issue. Failure of flue pipe or firebox due to creosote build up is not covered under warranty as excessive creosote build up is only possible from either unseasoned fuel or incorrect operation.

The Metro is noisy as it heats up and cools down

There will always be some expansion and contraction noise as the Metro heats and cools. This can usually be reduced by loosening three nuts at the rear of the appliance. To remedy, locate the 25mm deep cavity at the rear of your Metro between the 'rear panel' and the 'inner rear heat shield'. You will see a 6mm nut and two 6mm bolt heads in this cavity. Using a 10mm ring or open ended spanner, loosen all three so they are finger tight only.

On all Metro freestanding fires the air channel that allows the combustion air to enter the fire is fitted to the top underneath of the door opening. It is fitted with two M6 bolts. Slightly loosen both of these bolts.

Note: This does not apply to the ECO DV models.

The Metro won't turn down as much as it did

The door itself may need readjusting, the hinge and latch is slotted and allows for movement. Loosening the hinge and moving it back a few mm will make the door seal tighter and stop air leaking into the fire. The door and glass seals may be in need of replacing, which is generally required every 3-4 years.

Familiarise yourself with the instructions on page 10 before proceeding with this maintenance.

Warranty details for your Metro wood fire

Metro wood fires are manufactured in New Zealand, using the highest quality of materials, workmanship and the latest manufacturing techniques, which is why we offer a full 10 year firebox warranty and a 1 year parts warranty for your peace of mind.

Metro Warranty

(NZ Consumer laws apply to this warranty)

Pioneer Manufacturing Limited (Pioneer) warrants the steel firebox against defective materials and workmanship which would render it unfit for normal domestic use, from the date of purchase by the original consumer, for a period of 10 years.

Components including panel coating, door retainers, door seals, glass, trim, baffle & bricks are warranted for a period of 1 year from the date of original purchase for normal domestic use against defective materials and workmanship.

All associated accessories including, but not limited to, fans, flue systems, flue shields, wetbacks, tool sets, ash pots etc, are covered by a 1 year warranty against defective materials and workmanship.

It is recommended, but not a condition of this warranty, that a full service/inspection of the Metro fire be carried out at the end of each winter season.

Warranty Conditions

- The Metro fire must be installed, operated and maintained strictly in accordance with the building code and this installation and operation manual
- The Metro fire must be installed and used in a domestic application
- This warranty covers appliance like for like replacement or repair at the manufacturer's discretion but excludes freight, travel, installation, labour and/or any other associated costs
- Pioneer or their agents are not liable for any loss or expense direct or indirect arising from the failure of any part or operation of the appliance
- Operation of this appliance in violation of the warnings in this operation and installation manual will void this warranty
- Your Metro fire must be regularly maintained and we recommended it is also serviced annually. Proof of servicing may be required. If a wood fire is not regularly maintained and serviced, the life span will be reduced. If your Metro wood fire has been neglected, by not being regularly maintained and serviced, warranty may be declined

CAUTION! Important Information

Note: The following 3 points require regular inspection/maintenance (every time the ash bed is cleaned out, generally 3-5 times a season) and if not maintained will void the firebox warranty. Please ensure you keep your proof of purchase/receipt on any parts you buy.

- It is critical the fire not be operated with over worn, faulty or missing door seals. Door seals will harden over time and become over-worn (3-4 year's) and will cause air to leak into the fire, causing the appliance to 'over fire'. Do not operate the fire with cracked, or broken door glass
- It is critical the fire not be operated with over worn, faulty or missing bricks, baffle plate or baffle extension (white board on or under the baffle plate)
- A claim under this warranty should be directed to the retailer who supplied the Metro fire. If this is not possible write directly to the manufacturer stating details of fault, model, serial number of your Metro, dated proof of purchase and name of retailer purchased from.

Warranty Exclusions

(This manufacturer's warranty does not cover)

- Service calls which are not related to any defect in the product (i.e. operational, installation or fuel issues). The cost of a service call will be charged if the problem is not found to be a product fault
- Defects caused by factors other than normal domestic use or use in accordance with the product's operation manual
- Defects caused through the product being operated in an 'over-fired' manner resulting in sections of the firebox operating excessively hot to the point that sections glow red. (Note – This will result in distortion of the firebox)
- Defects to the product caused by accident, neglect, misuse or act of God
- The cost of repairs carried out by non-authorized repairers or the cost of correcting such unauthorised repairs
- Required maintenance as set out in this manual.

Service under this manufacturer's warranty must be provided by a repairer authorised by Pioneer Manufacturing Ltd. Such service shall be provided during normal business hours.

IMPORTANT! Complete and retain these details at time of purchase:

Purchase Date

Serial Number

Model

Colour

Retailer





Parts guide for your Metro – Promet, baffles and wetback options

Your Metro wood fire must be regularly maintained and we recommended it is also serviced annually. If a wood fire is not regularly maintained and serviced, the life span will be reduced.

If your Metro wood fire has been neglected, by not being regularly maintained and serviced, with authorised Metro parts replaced as required, your warranty may be declined.

Listed below are the parts and product codes for your Metro wood fire. The promet/baffle should be regularly checked and must always be in place during the operation of your fire.

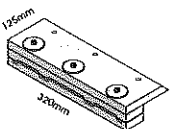
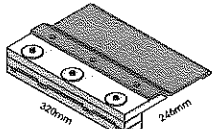
The baffle should be resting on four support lugs (two on each side of the firebox). It must be hard back against the rear of the firebox with the 'promet extension' (white board) or return front steel edge of the baffle facing forward.

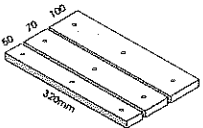
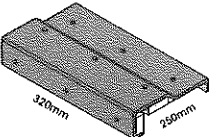
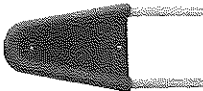
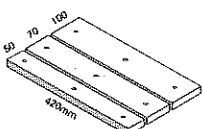
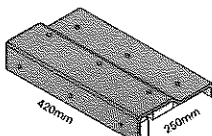
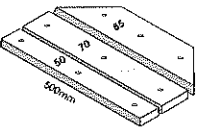
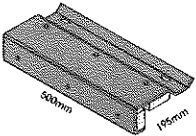
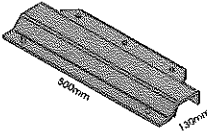
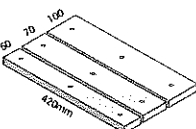
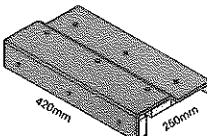
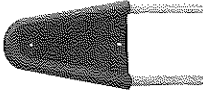
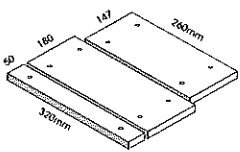
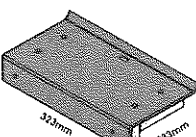
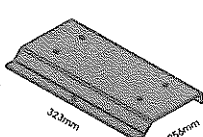
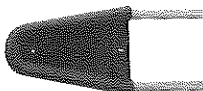





Model	Type of promet required / Type of steel baffle(s) required			Wetback options
<ul style="list-style-type: none"> • ECO Tiny Ped • ECO Tiny Rad 	<p>ECO Tiny Promet 500-1550</p> 	<p>ECO Tiny Baffle 500-2050</p> 	<p>ECO 2kW Booster 450-0050</p> 	
<ul style="list-style-type: none"> • Tiny Rad Woody 	<p>Tiny Woody Promet Set 500-2004</p> 	<p>Tiny Woody Baffle 500-2504</p> 	<p>Side Wetback 450-0275</p> 	
<ul style="list-style-type: none"> • R1 	<p>Wee/R1 Promet Set 500-2005</p> 	<p>Wee/R1 Baffle 500-2505</p> 	<p>No wetback can be fitted to this appliance</p>	
<ul style="list-style-type: none"> • R2 	<p>Xtreme/R2 Promet Set 500-2010</p> 	<p>Xtreme/R2 Front Baffle 500-2510</p> 	<p>Xtreme/R2 Rear Baffle 500-2515</p> 	<p>No wetback can be fitted to this appliance</p>
<ul style="list-style-type: none"> • Wee Rad • Wee Rad Base • Wee Rad Woody • Wee Ped 	<p>Wee/R1 Promet Set 500-2005</p> 	<p>Wee/R1 Baffle 500-2505</p> 	<p>Side Wetback 450-0275</p> 	
<ul style="list-style-type: none"> • Classic Rad 	<p>Classic Rad Promet Set 500-2015</p> 	<p>Classic Rad Front Baffle 500-2520</p> 	<p>Classic Rad Rear Baffle 500-2525</p> 	<p>Side Wetback 450-0275</p> 

Parts guide for your Metro – Promet, baffles and wetback options

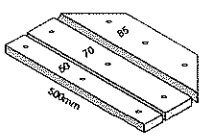
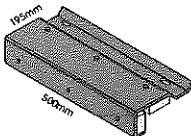
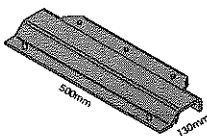
Hairline cracks in the promet extension are not uncommon and will have no adverse effect on the operation and performance of your Metro wood fire. These cracks are the result of intense heat coupled with expansion and contraction and is normal wear and tear.

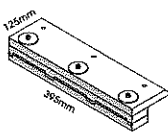
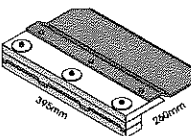
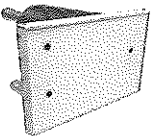
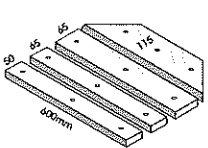
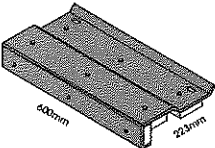
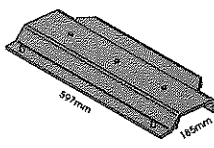
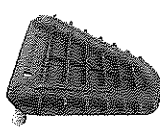
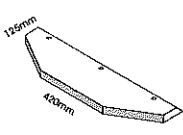
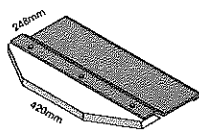
If the promet extension starts to break up and pieces fall into the firebox it must be replaced.

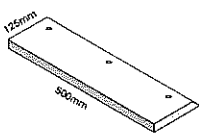
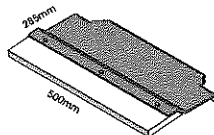
Note: Impact damage when loading wood and burning wood which is not properly seasoned, i.e. 25% moisture content or more, will cause the promet to disintegrate and require replacement. Always burn dry well seasoned wood and take care when loading wood into the firebox.

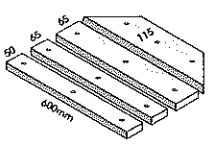
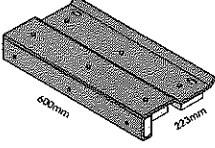
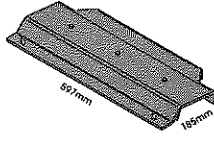
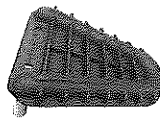
Model	Type of promet required / Type of steel baffle(s) required			Wetback options
<ul style="list-style-type: none"> Xtreme Rad Xtreme Rad Base Xtreme Rad Woody Xtreme Ped 	<p>Xtreme/R2 Promet Set 500-2010</p> 	<p>Xtreme/R2 Front Baffle 500-2510</p> 	<p>Xtreme/R2 Rear Baffle 500-2515</p> 	<p>3kW Wetback 450-0100</p> 
<ul style="list-style-type: none"> ECO Euro Ped DV 		<p>ECO DV Promet 500-1750</p> 	<p>ECO DV Baffle 500-2200</p> 	<p>ECO Wetback 450-0450</p> 
<ul style="list-style-type: none"> Mega Rad 	<p>Mega Rad Promet Set 500-2020</p> 	<p>Mega Rad Front Baffle 500-2530</p> 	<p>Mega Rad Rear Baffle 500-2535</p> 	<p>3kW Wetback 450-0100</p> 
<ul style="list-style-type: none"> LTD Wee Rad LTD Wee Rad Base LTD Wee Rad Woody 		<p>LTD Small Promet 500-1700</p> 	<p>LTD Small Baffle 500-2600</p> 	<p>3kW Wetback 450-0100 or 4kW Wetback 450-0150</p> 
<ul style="list-style-type: none"> LTD Xtreme Rad LTD Xtreme Rad Base LTD Xtreme Rad Woody 		<p>LTD Large Promet 500-1850</p> 	<p>LTD Large Baffle 500-2650</p> 	<p>3kW Wetback 450-0100 or 4kW Wetback 450-0150</p> 
<ul style="list-style-type: none"> LTD Mega Rad 	<p>Mega Rad Promet Set 500-2020</p> 	<p>Mega Rad Front Baffle 500-2530</p> 	<p>Mega Rad Rear Baffle 500-2535</p> 	<p>3kW Wetback 450-0100 or 4kW Wetback 450-0150</p> 

Metro - Visit us online today www.metrofires.co.nz

Metro wood fire specifications

Metro have a Specifications Brochure available which details relevant compliance data for every model. This brochure is updated annually and details the minimum clearances and specifications for all models, which is generally required when applying for a building consent. See your Metro retailer to obtain a copy, or visit www.metrofires.co.nz

metrofires.co.nz

Visit the Metro website: metrofires.co.nz to view Metro's 'video demos' showing the latest in wood fire technology energy saving options. You can view the entire Metro product range, find out where your nearest Metro retailer is located or simply check out the latest specifications, installation requirements and emission and efficiency data for the Metro of your choice.

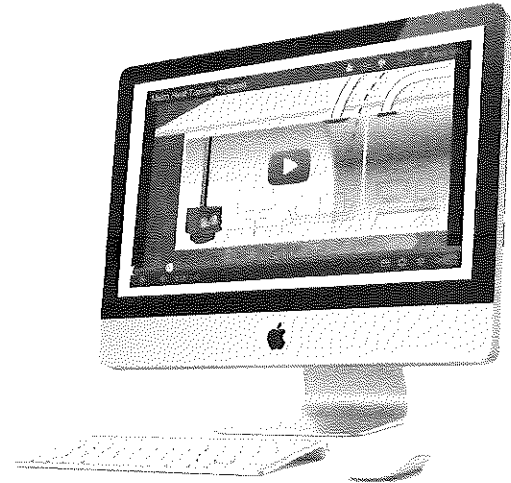

Pioneer heating accessories

Pioneer/Metro Fires offer a range of heating accessories designed to compliment your Metro wood fire. See below for some of the products within our heating accessory range. The range of accessories includes floor

protectors, heat transfer systems, child guards, baffles, bricks and more. For further details ask your Metro retailer for a copy of the Pioneer/Metro Fires heating accessories brochure, or visit www.metrofires.co.nz

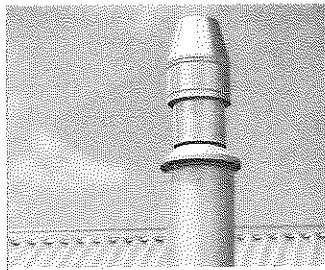

ECO Flue Systems

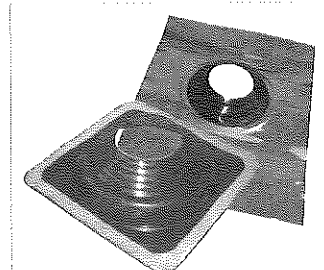

Flashrites and Versatiles

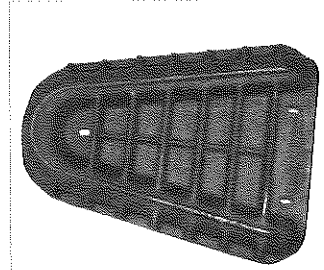

Wetbacks



High Temperature Paint

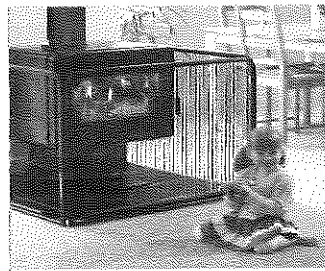

Child Guards

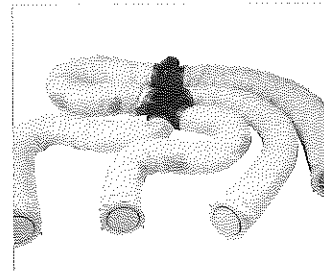

Heat Transfer Systems



Universal Door Seal Kits



Fire Cement And Silicone

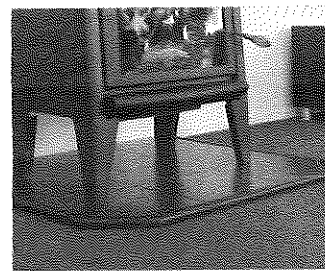

Corner and Wall Floor Protectors

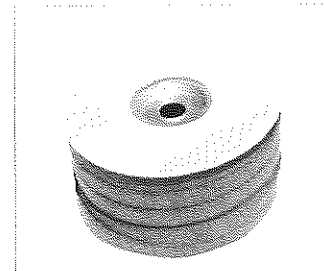

Glass Tape

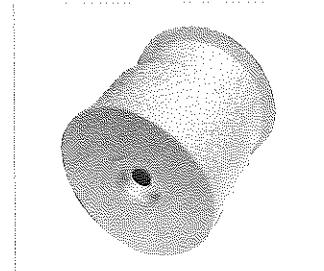

Door Seal Rope



Chubb Smoke Detectors

Standard Flue Kits

Courtesy of SFP (preferred supplier)

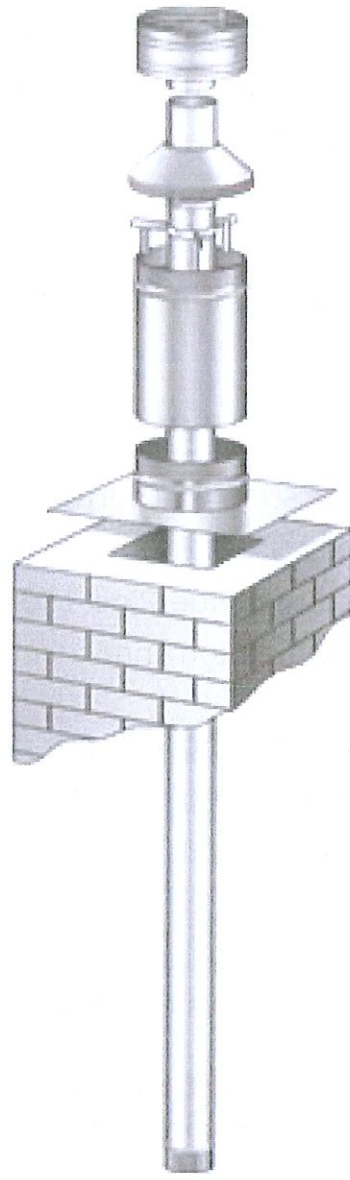
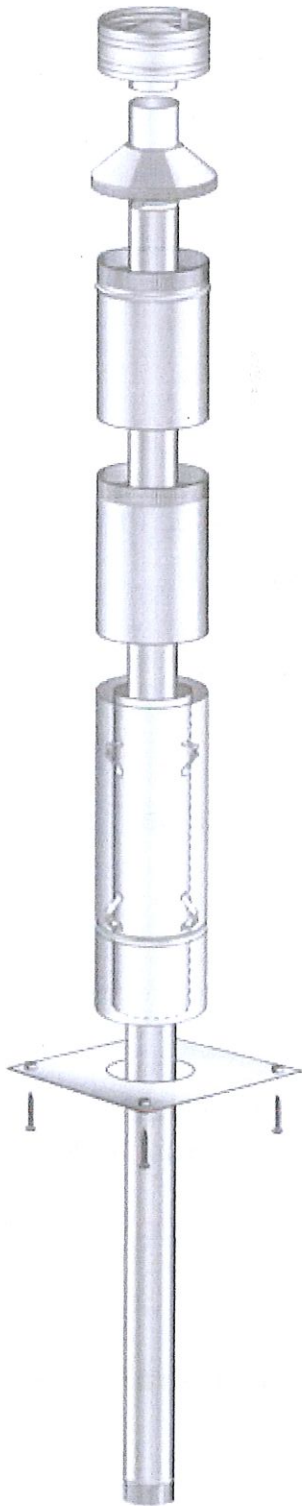

These Flue Kits are designed to meet the Flue Pipe height requirements of AS/NZS 2918:2001 (4.6m rule) for a standard 2.4m stud height and a Wood Burner height of 600mm or greater for either insert wood burner into non combustible chimney or a freestanding wood burner requiring a 150mm flue. For all other types of flue installation please refer to Broadys NZ or your installer for advise.

Standard Flue Kits

Courtesy of SFP (preferred supplier)

150mm Chimney Insert Flue Kit contains:

- 3 x 1200mm lengths of Stainless Steel Flue Pipe 150mm dia.
- 1 x 600mm length of Stainless Steel Flue Pipe 150mm dia.
- 1 x 600mm length of Galv. Outer Casing 250mm dia.
- 1 x Anti Down-Draught Cowl 150mm dia.
- 1 x Casing Cover 150/250.
- 1 x Top Spacer Bracket 150/250.
- 1 x Galv. Chimney Flashing Plate 250mm dia (optional)

150mm 4.0 Freestanding Flue Kit contains:

- 2x 1200mm lengths of Stainless Steel Hi Therm Black Flue Pipe 150mm dia.
- 1 x 1200mm lengths of Stainless Steel Flue Pipe 150mm dia.
- 1 x 600mm length of Stainless Steel Flue Pipe 150mm dia.
- 1 x 1200mm length of Galv Combination Inner/Outer Liner Pipes 200/250mm dia.
- 1 x 600mm length of Galv. Outer Casing 250mm dia.
- 1 x 600mm length of Galv. Outer Casing Slip extension 252mm dia.
- 1 x Anti Down-Draught Cowl 150mm dia.
- 1 x Casing Cover 150/250.
- 1 x Top Spacer Bracket 150/250.
- 1 x Flat Ceiling Plate with packet screws and spacers

4.0 metre kits meet the Flue Pipe height requirements of AS/NZS 2918:2001 (4.6 metre rule) for a standard 2.4m stud height and a Wood Burner height of 600mm or greater.

IMPORTANT: The above flue kits are NOT suitable for:

- **inbuilt wood burners or open wood fires requiring Zero Clearance triple skin flue systems**
- **Some types of solid fuel cooking appliances**
- **Non tested solid fuel domestic heating appliances**

Please refer to Broadys NZ Ltd or your Installer

Broadys takes no responsibility for installed flue systems that do comply with the requirements of AS/NZS2918:2001 or the Manufacturers Instructions that accompany the heating/cooking appliance

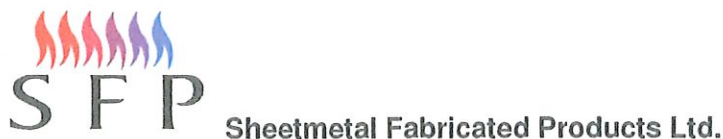

150MM CHIMNEY FLUE KIT INSTALLATION INSTRUCTIONS

THIS FLUE KIT HAS BEEN MANUFACTURED IN ACCORDANCE WITH AS/NZS 2918:2001.

WARNING: TO ENSURE SAFETY THIS FLUE KIT MUST BE INSTALLED AS OUTLINED IN THESE INSTRUCTIONS. THE APPLIANCE TO WHICH IT IS CONNECTED MUST BE INSTALLED IN ACCORDANCE WITH ITS MANUFACTURERS SPECIFICATIONS AND AS/NZS 2918:2001.

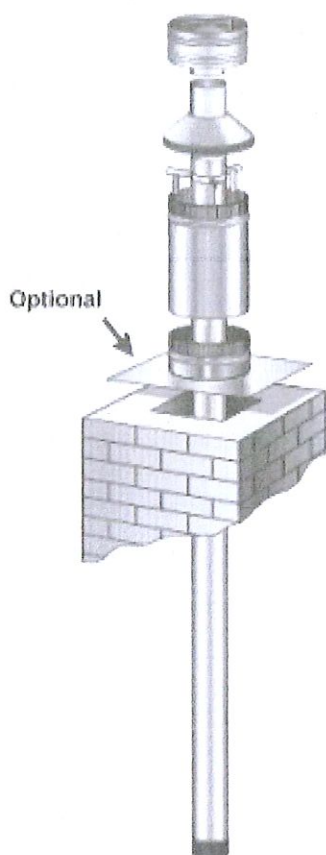

1) Ensure the chimney is clean and free of soot. Check the chimney for structural soundness.

2) Install Wood Fire into fireplace according to manufacturers specifications

3) By looking down chimney, check that heater flue outlet is in line with chimney. If not an OFFSET or BENDS will be required.

4) Assemble FLUE PIPES together ensuring seams are in line. Joints must be compressed fully and secured with 3 Monel Steel rivets.

Refer to the supplier of the Wood Fire and use FLUE PIPE sealant if recommended.

5) Lower assembled FLUE PIPE, crimped end down, into Wood Fire flue Spigot. On some installations it may be desirable to assemble FLUE PIPE lengths as they are lowered into the chimney.

6) Secure CHIMNEY FLASHING PLATE and/or OUTER CASING to chimney with suitable fasteners and weather seal to the chimney top with mortar and/or silicone.

7) Check the FLUE PIPE extends above the top of the CHIMNEY FLASHING PLATE or OUTER CASING 145 mm. Add sufficient stainless steel FLUE PIPE or trim OUTER CASING to attain this measurement.

8) Fix TOP FLUE SPACER BRACKET to the FLUE PIPE making sure the lugs fit snugly inside the OUTER CASING.

9) Fit CASING COVER over FLUE PIPE and push down firmly onto TOP SPACER BRACKET.

10) Fit COWL but do not secure, as removal for flue cleaning will be necessary. Deform or ovalise the stub of the COWL to ensure it is a tight friction fit.

11) Leave all installation and operating instructions with owner.



Sheetmetal Fabricated Products Ltd.

150 MM FREE STANDING WOODFIRE COMBINATION COWL FLUE KIT INSTALLATION INSTRUCTIONS

WARNING: THIS FLUE KIT HAS BEEN MANUFACTURED IN ACCORDANCE WITH AS/NZS 2918:2001 AND TESTED TO APPENDIX F. TO ENSURE SAFETY THIS FLUE KIT MUST BE INSTALLED AS OUTLINED IN THESE INSTRUCTIONS AND THE APPROPRIATE REQUIREMENTS OF THE RELEVANT BUILDING CODE OR CODES. WOOD FIRE AND FLUE CLEARANCES FROM COMBUSTIBLE WALLS MUST BE IN ACCORDANCE WITH WOOD FIRE MANUFACTURER'S SPECIFICATIONS AND AS/NZS 2918:2001. THESE INSTALLATION INSTRUCTIONS ARE FOR TESTED APPLIANCES ONLY.

CAUTION: MIXING FLUE SYSTEM COMPONENTS FROM DIFFERENT SOURCES OR MODIFYING THE DIMENSIONAL SPECIFICATION OF COMPONENTS MAY RESULT IN HAZARDOUS CONDITIONS. WHERE SUCH ACTION IS CONSIDERED, THE MANUFACTURER SHOULD BE CONSULTED IN THE FIRST INSTANCE.

CAUTION: IT IS THE RESPONSIBILITY OF THE INSTALLER TO ENSURE THAT THE INSTALLATION OF THIS FLUE KIT COMPLIES WITH AS/NZS 2918:2001, THE APPLIANCE MANUFACTURERS SPECIFICATIONS FOR FLUE PIPE SHIELD AND CEILING PLATE AND THAT THE RELEVANT BUILDING CODES ARE ADHERED TO.

BENDS AND EXTENSIONS TO THE LENGTH OF A FLUE SYSTEM ARE PERMITTED (AS/NZS 2918 2001 4.1)

- 1) Locate Wood Fire in its proposed position and mark a point on the ceiling that is directly above the centre of the Wood Fire's Flue Spigot. Check that the Wood Fire's location allows the OUTER CASING to clear all structural roof timbers.
- 2) Cut a 250mm square hole in ceiling. Directly above cut a hole in roof to accommodate OUTER CASING.
- 3) Fit timber nogs around ceiling. i.e. Nogs form a 250mm square aperture that allows air to circulate freely over the OUTER CASING surface.
- 4) Position the OUTER CASING so that it is flush with the underneath of the ceiling and protrudes through the roof the required height. Note that AS/NZS 2918:2001 4.9.1(a) states, "the FLUE PIPE shall extend not less than 4.6m above the top of the floor protector". Refer to diagram B.
 - a) If the FLUE PIPE is within 3 metres of the ridge, the FLUE PIPE must protrude at least 600mm above the ridge of the roof.
 - b) If the distance from the ridge is more than 3 metres, the FLUE PIPE must protrude at least 1000mm above roof penetration.
 - c) The FLUE PIPE must be more than 3 metres from any nearby structure. (Refer diagram C).

Additional OUTER CASING and INNER CASING may have to be added to ensure the following:

- I) The correct minimum roof penetration height.
- II) Sufficient overall height to encase the FLUE PIPE which must extend a minimum of 4.6 metres from the floor protector. Refer diagram B.

Note that the INNER CASING should extend 200mm above roof penetration.

NB: Do not secure the OUTER CASING SLIP EXTENSION onto the OUTER CASING, as final adjustment will be required when fitting cowl assembly. See Paragraph 11.

- 5) Fix an appropriate flashing around the OUTER CASING to seal onto the roofing material. Refer to the manufacturer's recommendations for correct fitting. NB: On iron roofs, fixings such as metal angle brackets (approximately 25mm x 25mm) can be fitted under the flashing to securely fix the roof to OUTER CASING.
- 6) Drill holes in CEILING PLATE for the fixing screws. Place CEILING PLATE over Wood Fire Flue Spigot, ensuring the folded edges are facing the ceiling.
- 7) Position bottom length of FLUE PIPE (crimped end downwards) into Wood Fire Flue Spigot.

Refer to the supplier of the Wood Fire and use flue pipe sealant if recommended.

- 8) Assemble FLUE PIPES together ensuring seams are straight, offsetting the seams will ensure a neat fit. FLUE PIPES **must** be assembled with crimped ends down (towards Wood Fire). Secure each joint with a minimum of 3 monel steel rivets equally spaced around the joint.. If using HI-THERM FLUE PIPE the protective wrapping should be left on the FLUE PIPE during installation.
- 9) From the roof lower FLUE PIPE through OUTER CASING into the bottom FLUE PIPE securing with three monel rivets.
- 10) Check that the FLUE PIPE SPACING BRACKETS inside the INNER CASING are correctly positioned and then from the roof slide the INNER CASING into the OUTER CASING until the brackets rest on to the internal swage ring of the OUTER CASING, this will ensure the INNER CASING is the correct 12mm above ceiling level.

Check the INNER CASING when correctly positioned extends a minimum of 200mm above the roof penetration.

- 11) Before securing the OUTER CASING SLIP EXTENSION to the OUTER CASING with 3 rivets, ensure the FLUE PIPE is either flush with or extends above the top of the OUTER CASING SLIP EXTENSION by no more than 15mm. Adjust SLIP EXTENSION to obtain this measurement.
- 12) Push CASING COVER (with spigot inside FLUE PIPE) down onto the OUTER CASING SLIP EXTENSION. The 3 locating brackets with holes must be on the outside of the OUTER CASING SLIP EXTENSION and are secured using 3 rivets.
- 13) Fit COWL but do not secure, as removal for flue cleaning will be necessary. Deform or ovalise the stub of the COWL to ensure it is a tight friction fit.
- 14) Fasten CEILING PLATE to ceiling using screws and ceramic spacers provided. Ensure an even air gap around FLUE PIPE when fixing. Remove protective plastic from CEILING PLATE. N.B. 12mm air gap between ceiling plate and ceiling must be maintained.
- 15) Leave all installation and operating instructions with the owner.

Cleaning of Flue Pipes before lighting the fire.

Stainless Steel pipe should be wiped clean using a soft cloth and methylated spirits to remove finger marks and oils used to manufacture the flue pipe.

Hi-Therm flue pipe can be touched up using only STOVE BRIGHT aerosol paint.



150mm Free Standing Wood Fire Combination Cowl Flue Kit Installation Instructions Complies with AS/NZS 2918:2001

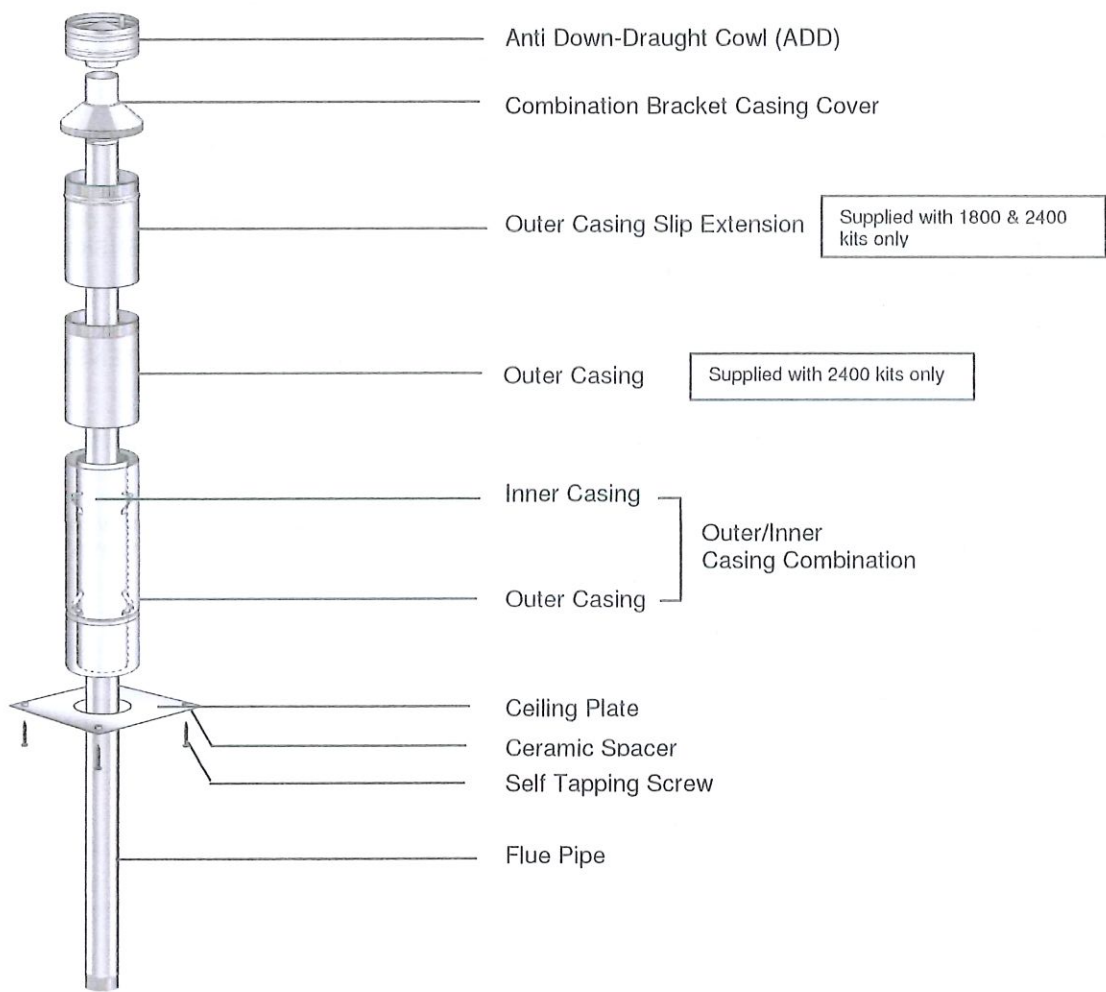

Diagram B

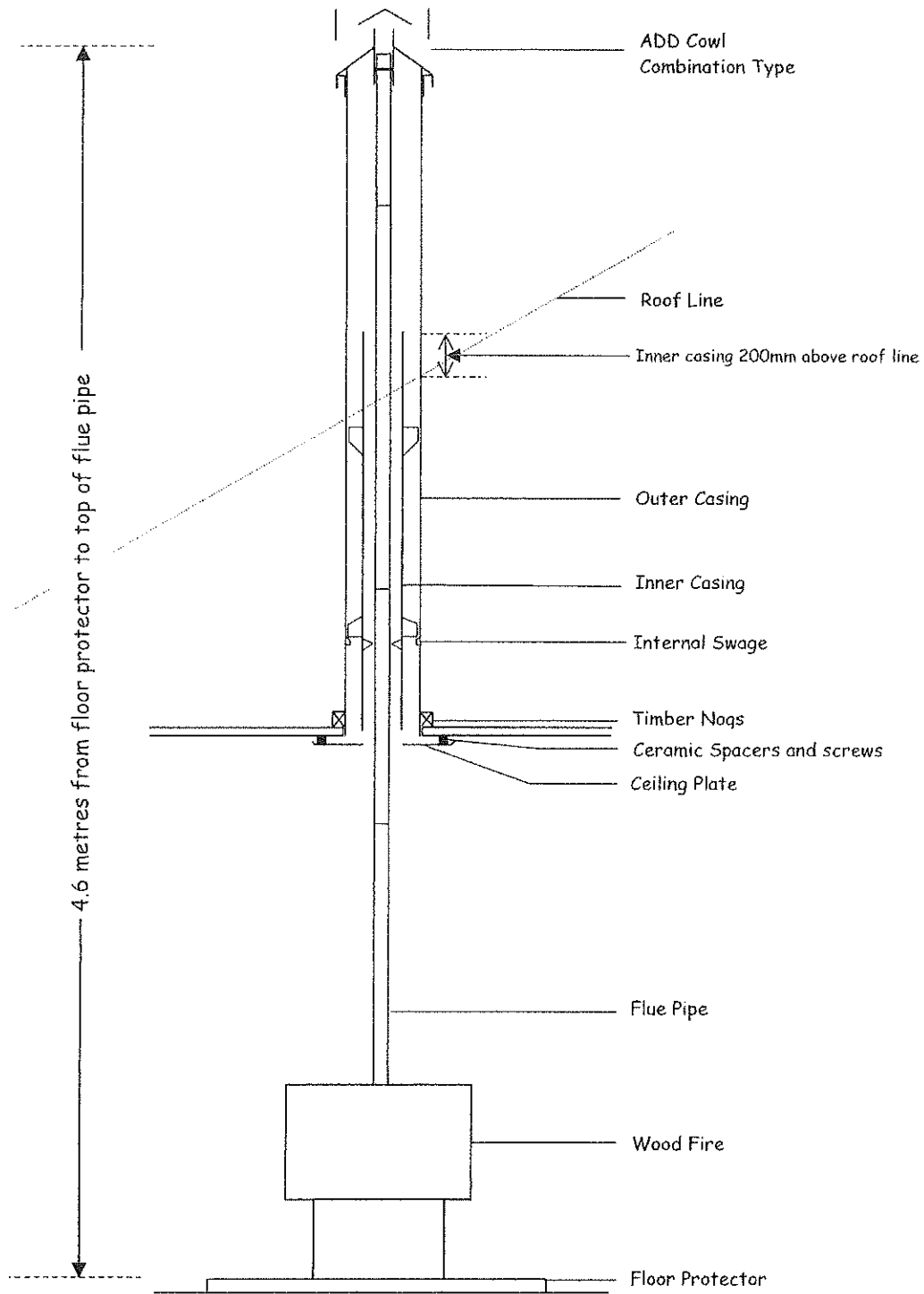
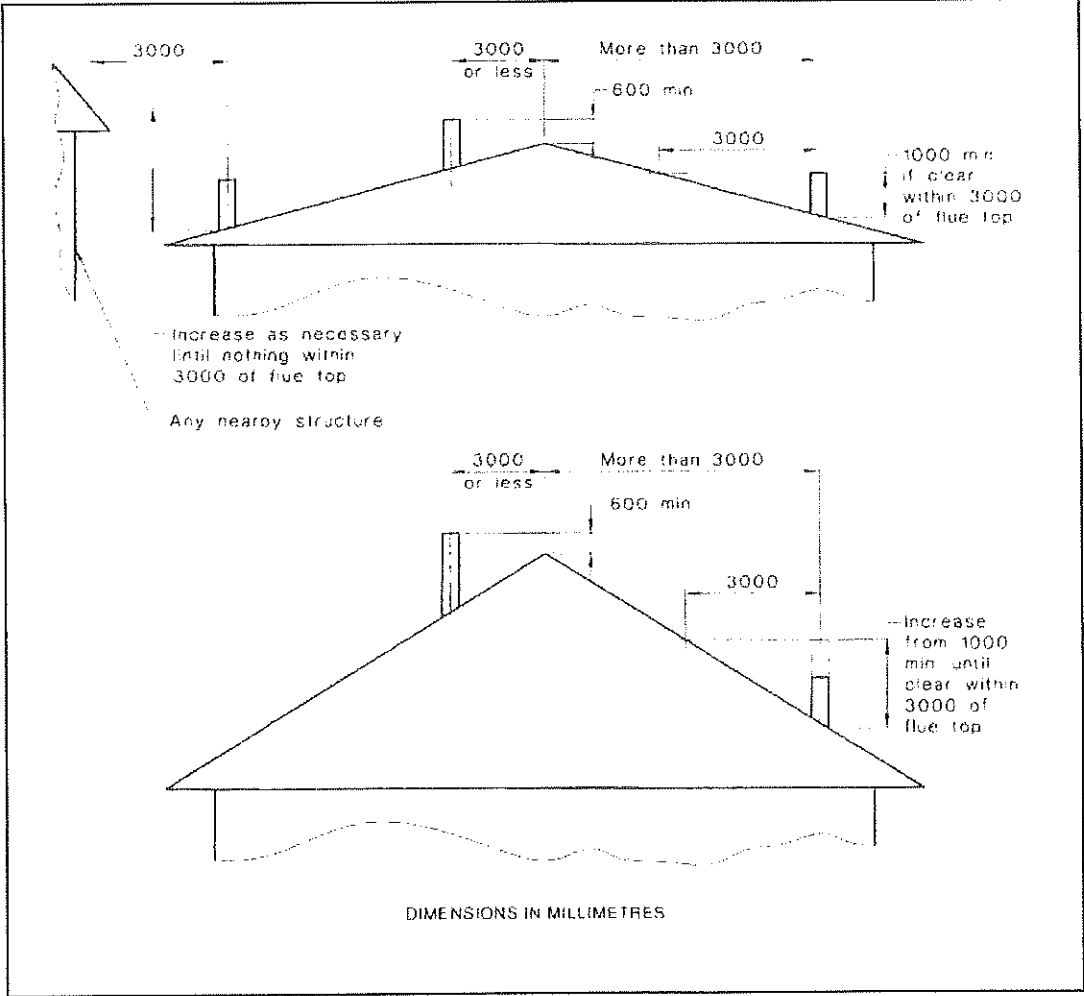

Diagram C AS/NZS 2918:2001 pg 37



HI-THERM STAINLESS STEEL FLUE PIPES

- *HI-THERM Flue Pipe is a high temperature, matt finish Flue Pipe designed for use on slow combustion, solid fuel heaters.*
- *HI-THERM Flue Pipe is ideal for heaters that have high flue temperatures and that also can be operated under circumstances that may produce creosoting of Flue Pipes for short periods of time, ie, on refuelling and with air control in shut or low position. Clean air guidelines must be observed.*
- *HI-THERM Flue Pipe is a **maintainable** product.*

CONDITIONS OF USE

- *The Wood Fire must be operated in accordance with the manufacturer's instructions. Clean air guidelines and regulations must be observed.*
- *HI-THERM Flue Pipe must be swept by mechanical means only. (We recommend mixed head or polypropylene brushes). Under **NO** circumstances should chemical flue cleaners, (soot destroyers) or steel chimney brushes be used.*
- *HI-THERM Flue Pipe should not be used on a Wood Fire burning treated or wet (unseasoned) wood. **Only use newspaper when lighting the fire; never burn colour printed brochures or junk mail.***
- *HI-THERM Flue Pipes **must** be secured together with a minimum of three Monel Steel rivets equally spaced around the joint.*
- *The paint finish appearance may change, depending on heater operation and is designed to be a **MAINTAINABLE** finish. To maintain paint finish or touch up use only genuine **STOVE BRIGHT** Aerosol. (Refer label on packaging).*
- *HI-THERM Flue Pipe must be installed in accordance with SFP installation instructions, using flue componentry supplied by SFP. It is the responsibility of the installer to ensure no water leaks into the Hi-Therm Flue System.*
- *The Stainless Steel Flue Pipe used in "Hi-Therm Stainless Steel Flue Pipe" is warranted for five years, providing the above conditions are met.*

**FAILURE TO OBSERVE THESE CONDITIONS
MAY NEGATE WARRANTIES**

Dektite Aluminium

The best solution for stone chip and pressed metal tiles

- ✓ The base is 99.9% pure grade aluminium making it strong, malleable and easy to install.
- ✓ Environmentally friendly, ideal where potable water is collected.
- ✓ The best solution for stone chip and pressed metal tiles.
- ✓ EPDM withstands temperatures from -50°C to 115°C and up to 150°C intermittently.

Code	Base (mm)	Pipe (mm)	Pitch	Colour
TFA 12-70	500 x 600	12-70	0-45°	BLACK (EPDM)
TFA 50-170	600 x 600	50-170	0-45°	
TFA 110-220	764 x 764	110-200	0-45°	
TFA 160-300	764 x 764	160-300	0-45°	
TFA 300-450	965 x 965	300-450	0-45°	



Installation Instructions:

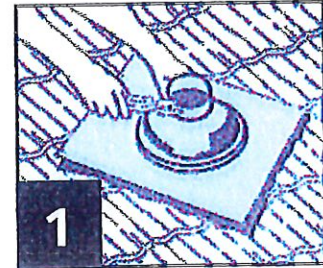

Trim Dektite cone to suit pipe size using sharp tin snips.

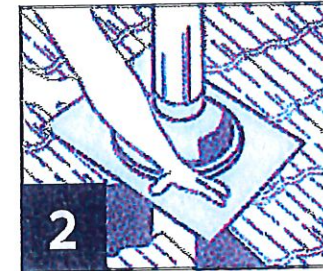

After lubricating the flue with water, slide Dektite down to the tile level.

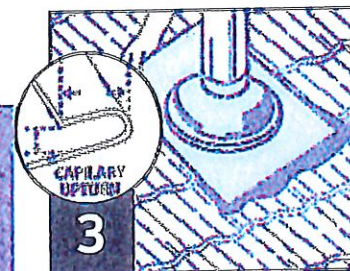

Form an anti-capillary fold then place upper edge of base under up-stream tiles.

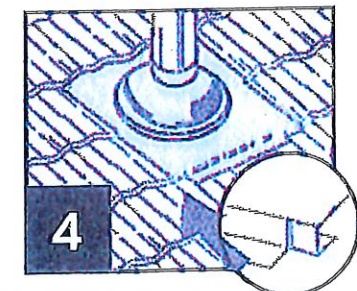

Dress base to profile, cut tabs on the bottom corners and fold under to stop wind lift.