



Important Note:

All documentation is required to be onsite as per the original sizes or available via a laptop etc.

And failing to do so may result in a terminated inspection and may result in further charges.



INSPECTION RECORD

This record, together with the Building Consent and approved plans, is to remain on the construction site at all times.

Project Location	TO BOOK AN INSPECTION PLEASE PHONE WDC BUILDING CONTROL	BCon18/0540
224 Brunswick Rd WHANGANUI	ON 349 0001 AND QUOTE THE FOLLOWING APPLICATION NUMBER:	
Description of Work	Install a Metro ECO Trend Insert wood burner in the kitchen dining area.	
Applicant	InterIsland Consulting Ltd PO Box 143, Ohakune 4660	

SUMMARY OF CONDITIONS

Building Consent Number BCon18/0540

PIM Conditions

Code	Condition
	All work on the project must comply with the requirements of the NZ Building Code.
	A PIM only document is not an approval to build. A Building Consent is required before building work commences.
	W.D.C will follow up on building work not completed within two years of building consent issue.
	A Building Consent lapses and is of no effect if the building work has not been started within 12 months of the date of issue.
	If the building is public premises it may not be occupied until either a code compliance certificate or certificate for public use has been issued.
	Please note [Electrical, and Gasfitting subtrades do not form part of the building consent inspection process. However, Council is required to receive 'Energy Certificates' from both of these trades before issue of a Code Compliance Certificate].

Building Consent Conditions

Code	Condition

Your project's inspections are listed on the next page...



Please Note: A minimum of 48 hours notice is required for the booking of an inspection. The inspection record sheet and accompanying building consent documentation must be on site for use by the inspector at the time of the inspection.

All inspections are to be carried out by BCA Building Inspectors unless prior arrangements have been made by the BCA to have an approved qualified person inspect specific items (eg. Engineer). Inspections shall be carried out in accordance with the attached schedule of inspection types. It is the owner's responsibility to ensure all necessary inspections are carried out as required. Please contact WDC if you are unsure what requires inspection – do not cover or enclose any building work without inspection.

Note: Further inspections may incur additional cost at time of Code Compliance Certificate issue.

Inspections Record For Building Consent Number BCon18/0540								
<i>Inspection</i>	<i>When to Request</i>	<i>Date</i>	<i>Inspector</i>	<i>Complies with Code</i>	<i>Reinspect</i>	<i>Notes</i>		
FINAL BUILDING INSPECTION	On Completion					Before requesting a final inspection please supply the following information: Application for Code Compliance Certificate (Form 6)		
INBUILT HEATER INSPECTION	To inspect the chimney prior to installation.					Pre installation check of chimney		



BUILDING CONSENT NUMBER BCon18/0540

Section 51, Building Act 2004

The building:

Street address of building:	Legal description of land where building is located:
224 Brunswick Rd WHANGANUI	LOT 3 DP 2187 2.1144 Ha
Building name:	Location of building within site/block number:
Level/unit number:	

The owner:

Name of Owner:	
Ms JE Exmoor, Ms JMR Morrell	
Mailing address:	Street Address/registered Office:
224 Brunswick Road RD 1 Whanganui 4571	224 Brunswick Road RD 1 Whanganui 4571

Phone numbers:

Landline:	3433363	Mobile:	0211269959
Daytime:	063490506 3490506 ext 2	After hours:	
Facsimile number:			
Email address:		Website:	

First point of contact for communications with the building consent authority:

Contact Person:	
InterIsland Consulting Ltd	
Mailing address:	Street Address/registered Office:
PO Box 143, Ohakune 4660	PO Box 143, Ohakune 4660

Phone number:

Landline:		Mobile:	0275245532
Daytime:		After hours:	
Facsimile number:			
Email address:		Website:	

Building Work

The following building work is authorised by this consent

Project
Install a Metro ECO Trend Insert wood burner in the kitchen dining area.

<i>Intended Use</i>	<i>Intended Life</i>
Single Detached Residential	50+ Years
<i>Estimated Value (\$)</i>	
\$4500.00	

This building consent is issued under section 51 of the Building Act 2004. This building consent does not relieve the owner of the building (or proposed building) of any duty of responsibility under any other Act relating to or affecting the building (or proposed building). This building consent also does not permit the construction, alteration, demolition, or removal of the building (or proposed building) if that construction, alteration, demolition or removal would be in breach of any other Act.



PROJECT INFORMATION MEMORANDUM NUMBER BCon18/0540

Section 31, Building Act 1991

InterIsland Consulting Ltd
PO Box 143
Ohakune 4660

<i>Project Location</i>	<i>Assessment Number/Legal Description</i>
224 Brunswick Rd WHANGANUI	LOT 3 DP 2187 2.1144 Ha
<i>Category</i>	<i>Description of Work</i>
Inbuilt Solid Fuel Heater	Install a Metro ECO Trend Insert wood burner in the kitchen dining area.
<i>Intended Life</i>	<i>Estimated Value (\$)</i>
50+ Years	4500.00

This Project Information Memorandum is confirmation that the proposed work may be undertaken, subject to the provisions of the Building Act 2004 and any requirements of the Building Consent (number BCon18/0540), which has been granted.

This Project Information Memorandum is subject to the following conditions:

- **All work on the project must comply with the requirements of the NZ Building Code.**

Signed for and on behalf of the Whanganui District Council

Bill Leslie
Senior Building Control Officer

Date: 10 August, 2018



CONDITIONS OF BUILDING CONSENT NUMBER BCon18/0540

Section 51, Building Act 2004

This Building Consent is issued Subject to the following conditions:

Building Act 2004, Section 90:

Inspections by Building Consent Authorities

Agents authorised by the building consent authority for the purposes of this section are entitled, at all times during normal working hours or while building work is being done, to inspect

- (a) land on which building work is being or is proposed to be carried out; and
- (b) building work that has been or is being carried out on or off the building site; and
- (c) any building.

Informative notes:

- [Informative note: The Building Consent, conditions, inspection sheet, and approved plans must be kept on site at all times until completion of the project.]
- [Informative note: Failure to request inspections will risk the non-issuing of a code compliance certificate and the structure may be deemed non-complying.]
- [Informative note: Any inspection time required over and above that allowed may incur a further charge.]
- [Informative note: Under Section 52, a building consent lapses and is of no effect if the building work to which it relates is not commenced within 12 months after the date of issue.]
- [Informative note: Under Section 93, if the owner has not made application within 24 months, the BCA (Building Control Authority), must decide whether or not to issue a CCC (Code Compliance Certificate).]

Compliance Schedule:

A compliance schedule (CS) is not required for this building.

#Attachments

- ‡Copies of the following documents are attached to this building consent:
- ‡Project information memorandum number BCon18/0540'
- ‡Inspection record

Signed for and on behalf of the Whanganui District Council

Bill Leslie
Senior Building Control Officer

Date: 10 August, 2018

THESE DRAWINGS ARE THE PROPRIETARY WORK PRODUCT AND PROPERTY OF INTERISLAND CONSULTING LTD., DEVELOPED FOR THE EXCLUSIVE USE OF JANE EXMOOR. USE OF THESE DRAWINGS AND CONCEPTS CONTAINED THEREIN WITHOUT HER WRITTEN PERMISSION PROHIBITED AND MAY SUBJECT YOU TO A CLAIM FOR DAMAGES.

Sheet #
1

Drawn By:
Bill Moore
Interisland
Consulting Ltd
+64 27 524 5532
Safety First: No Problems Only Solutions

Date:
6/08/2018
Scale: 1:1000

Consent Issue



COMPUTER FREEHOLD REGISTER
UNDER LAND TRANSFER ACT 1952



R. W. Muir
Registrar-General
of Land

Identifier **WN182/228**
Land Registration District **Wellington**
Date Issued 15 April 1909

Prior References
WN141/260

Estate Fee Simple
Area 2.1145 hectares more or less
Legal Description Lot 3 Deposited Plan 2187

Proprietors
Jane Elaine Exmoor as to a 1/3 share
Jan Marie Rachel Morrell as to a 2/3 share

Interests

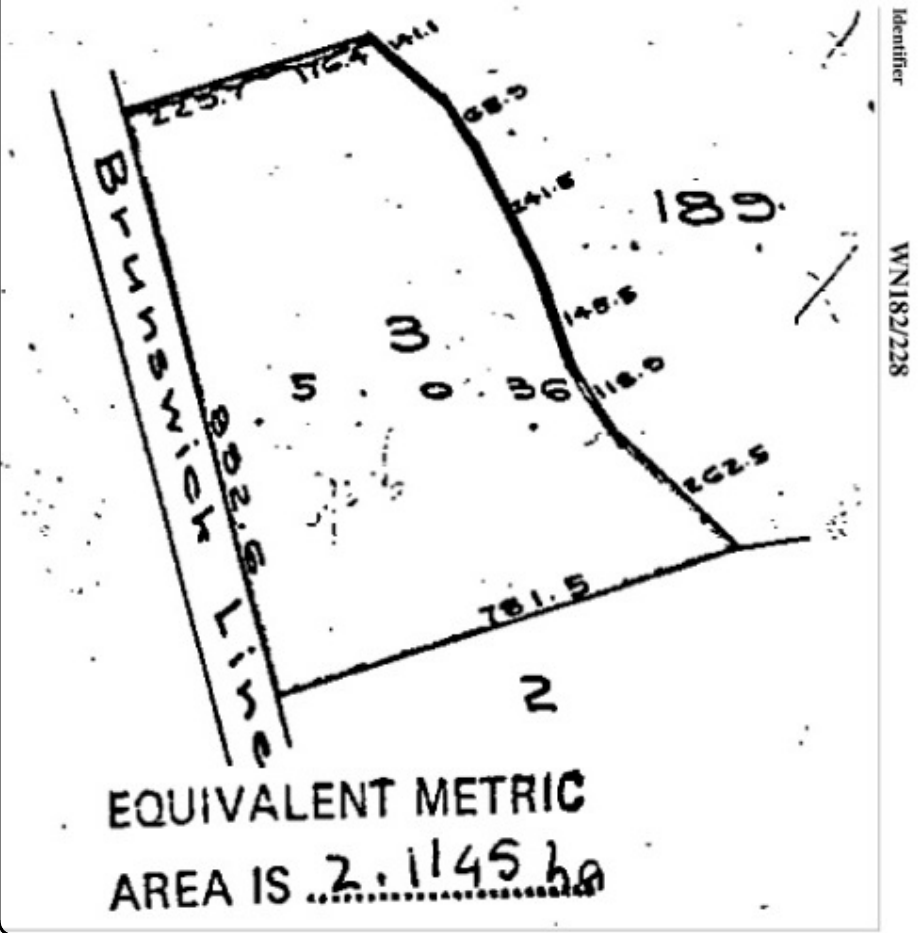

Wood Burner Consent
Jane Exmoor & Jan Morrell



224 Brunswick Rd
Lot 3 DP 2187
Area 2.1144ha

Certificate of Title & Site Plan

THESE DRAWINGS ARE THE PROPRIETARY WORK PRODUCT AND PROPERTY OF INTERISLAND CONSULTING LTD., DEVELOPED FOR THE EXCLUSIVE USE OF JANE EXMOOR. USE OF THESE DRAWINGS AND CONCEPTS CONTAINED THEREIN WITHOUT HER WRITTEN PERMISSION PROHIBITED AND MAY SUBJECT YOU TO A CLAIM FOR DAMAGES.

Sheet #
1

Drawn By:
Bill Moore
Interisland
Consulting Ltd
+64 27 524 5532
Safety First: No Problems Only Solutions

Date:
4/08/2018
Scale: 1:1000

Consent Issue



COMPUTER FREEHOLD REGISTER
UNDER LAND TRANSFER ACT 1952



R. W. Muir
Registrar-General
of Land

Identifier **WN182/228**
Land Registration District **Wellington**
Date Issued 15 April 1909

Prior References
WN141/260

Estate Fee Simple
Area 2.1145 hectares more or less
Legal Description Lot 3 Deposited Plan 2187

Proprietors
Jane Elaine Exmoor as to a 1/3 share
Jan Marie Rachel Morrell as to a 2/3 share

Interests

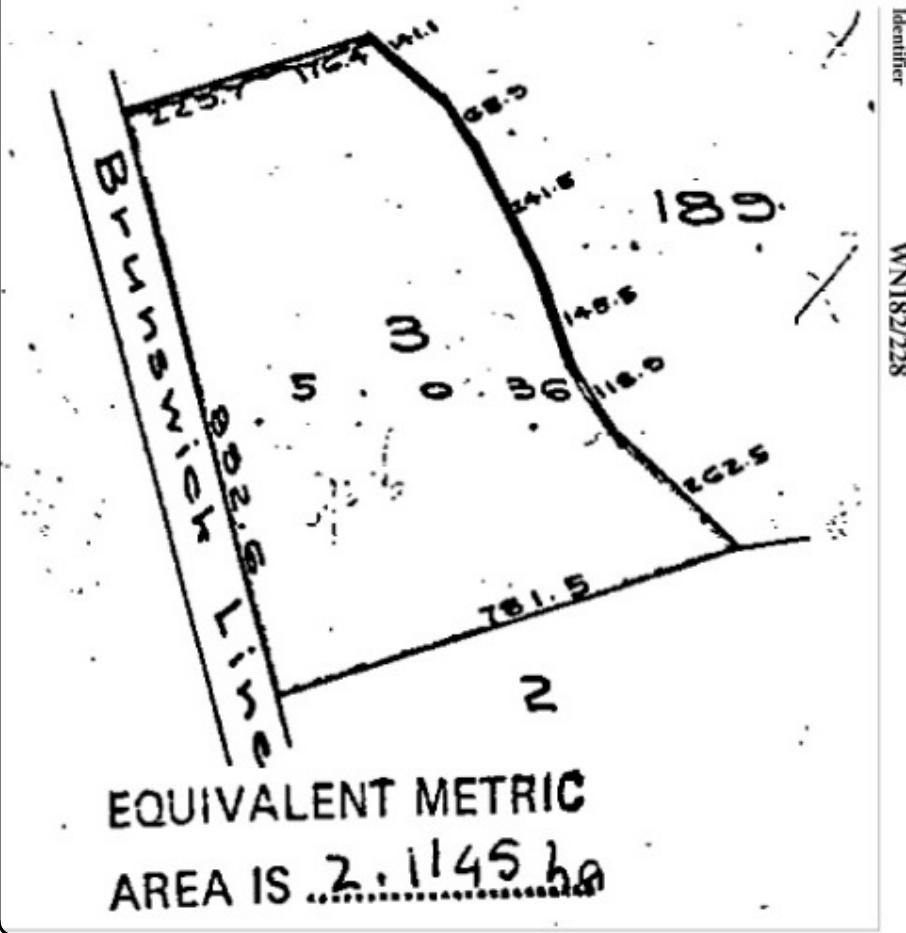

Wood Burner Consent
Jane Exmoor & Jan Morrell



224 Brunswick Rd
Lot 3 DP 2187
Area 2.1144ha

Certificate of Title & Site Plan

THESE DRAWINGS ARE THE PROPRIETARY WORK PRODUCT AND PROPERTY OF INTERISLAND CONSULTING LTD., DEVELOPED FOR THE EXCLUSIVE USE OF JANE EXMOOR. USE OF THESE DRAWINGS AND CONCEPTS CONTAINED THEREIN WITHOUT HER WRITTEN PERMISSION PROHIBITED AND MAY SUBJECT YOU TO A CLAIM FOR DAMAGES.

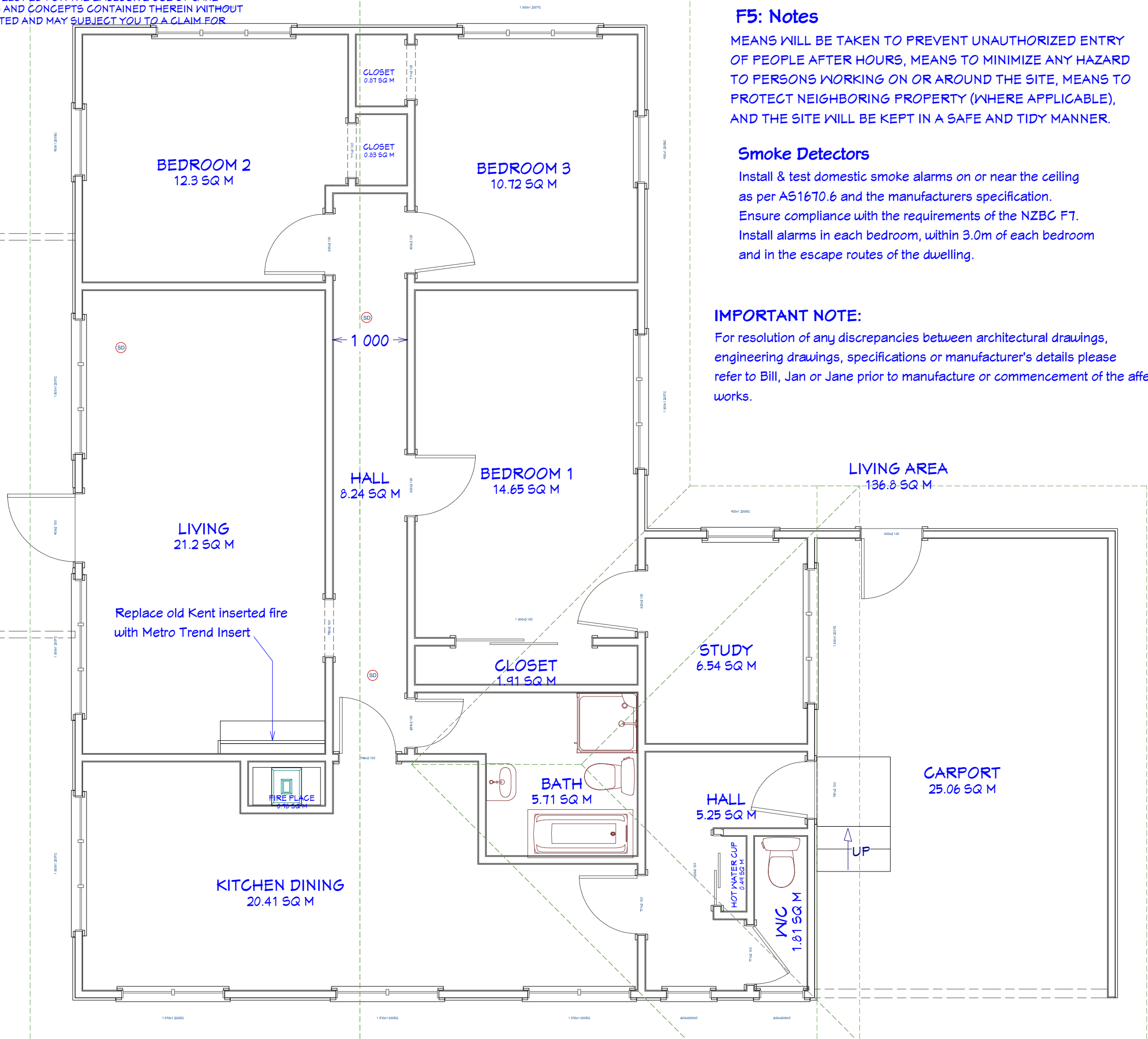

F5: Notes

MEANS WILL BE TAKEN TO PREVENT UNAUTHORIZED ENTRY OF PEOPLE AFTER HOURS, MEANS TO MINIMIZE ANY HAZARD TO PERSONS WORKING ON OR AROUND THE SITE, MEANS TO PROTECT NEIGHBORING PROPERTY (WHERE APPLICABLE), AND THE SITE WILL BE KEPT IN A SAFE AND TIDY MANNER.

Smoke Detectors

Install & test domestic smoke alarms on or near the ceiling as per AS1670.6 and the manufacturers specification. Ensure compliance with the requirements of the NZBC F7. Install alarms in each bedroom, within 3.0m of each bedroom and in the escape routes of the dwelling.

IMPORTANT NOTE:

For resolution of any discrepancies between architectural drawings, engineering drawings, specifications or manufacturer's details please refer to Bill, Jan or Jane prior to manufacture or commencement of the affected works.

THESE DRAWINGS ARE THE PROPRIETARY WORK PRODUCT AND PROPERTY OF INTERISLAND CONSULTING LTD., DEVELOPED FOR THE EXCLUSIVE USE OF JANE EXMOOR. USE OF THESE DRAWINGS AND CONCEPTS CONTAINED THEREIN WITHOUT HER WRITTEN PERMISSION PROHIBITED AND MAY SUBJECT YOU TO A CLAIM FOR DAMAGES.



P.O. BOX 687, NELSON, NEW ZEALAND

PHONE (03) 547 7347
FAX (03) 547 2909
EMAIL: applied@ts.co.nz
WEB: www.appliedresearch.co.nz

Report 05/1309 November 23rd, 2005 Page 1/1

Customer: Pioneer Manufacturing Ltd.
Mamaku St.
P.O. Box 11
INGLEWOOD

Accreditation

This laboratory is accredited by International Accreditation New Zealand (formerly Telarc). The tests reported herein have been performed in accordance with the terms of our accreditation. This accreditation does not extend to any opinions or any interpretations of test results contained in this report.



Laboratory Registration Number 395

Emissions/Efficiency Test Certificate

Appliance: Metro ECO Insert
Tested Standard: AS/NZS4012:1999 and AS/NZS4013:1999
Test Fuel: Softwood
Configuration: Insert
Thermal Efficiency: 65.0%
Emissions Rate: 0.91g/kg
Full Report Ref.: 04/1096

This report:

Prepared by: C.J. Mildon

Approved by: C.J. Mildon

Release Date:

C.J. Mildon
C.J. Mildon
23-11-05

This report must not be reproduced except in full. Results are based on material and information supplied by the client. Applied Research Services Ltd shall not be liable in respect of any loss or damage (including consequential loss or damage) resulting from the use of reports prepared by them. Results issued in electronic form are subject to confirmation by issue of final report.

ECO Trend Insert

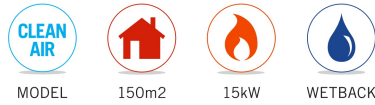

The ECO Trend Insert is a perfect fit for new and existing installations into either a masonry chimney or timber framed cavity¹. The thermo fan is required for all installations in a clean air zone and further enhances the convected heat output and circulation. Wetback options are available for properties with a land size of 2Ha or greater. Fascia finished in black vitreous enamel.

Heat type: Convection
Heating area: 150m² / 3 bedroom home
Finish: Black vitreous enamel finish
Wetback: Non-clean air zones only (2Ha+) 3kW or 4kW wetback
ECan Authorisation #: 101159 (DRY)
Emission: 0.91gms (DRY)
Efficiency: 65% (DRY)

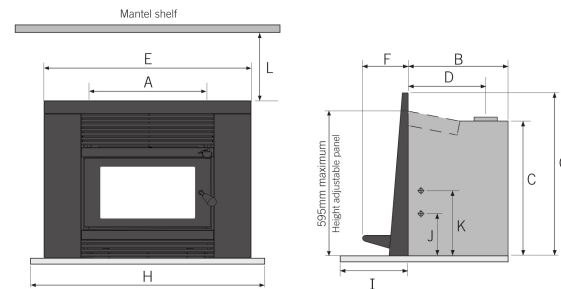

Metro insert and built-in fires are tested to comply with AS/NZS 2918:2001 incorporating Appendix 'E' when installed in accordance with the manufacturers installation/operation manual supplied with each fire.

	Firebox Width	Firebox Depth	Firebox Height	Flue Centre	Fascia Width	Fascia Depth	Fascia Height	Min. Floor Protector Width	Min. Floor Protector Projection	Wetback In	Wetback Out	Mantel Clearance
ECO Trend Insert	560	500	550	405	810	185	650	825	300	170	360	340

Please note: All measurements detailed for the ECO Trend Insert exclude the 13mm insulating blanket. See Installation/Operation manual for full installation details.
¹ The ECO Trend Insert can be converted in to a Built-in appliance and installed into a timber framed cavity (false chimney) with the addition of the appliance specific Metro Vented Zero Clearance Cabinet (VZCC). Please see your Metro dealer or go to metrofires.co.nz for full details.

All details are correct and current at the time of printing. Specifications are subject to change without notification.

Clean Air Approved
Suitable for any size property. Can be installed into Clean Air Zones.

Heating Area m2
The floor area the Metro wood fire is capable of heating.
(Estimated on 2.4m stud height in an average NZ climate/insulation)

Kilowatt Output
Peak heat output with a Metro ECO Flue System fitted.
(A Metro ECO Flue System will increase overall heat efficiency in your home)

Optional Wetback
Can be fitted with an energy saving wetback to assist with your water heating requirements.

Sheet #

3

Drawn By:
Bill Moore
Interisland
Consulting Ltd
+64 27 524 5532
Safety First: No Problems Only Solutions

Date:
4/08/2018
Scale: 1:50

Consent Issue

Wood Burner Consent
Jane Exmoor & Jan Morrell
Clearances & EET Cert.



224 Brunswick Rd
Lot 3 DP 2187
Area 2.1144ha

RE: Whanganui Solid Fuel Heater Consent Authorisation Letter to act as
an agent

En 18/0640 WDC Approved Plans 10/08/2018

5th August 2018

We give consent for Bill Moore from InterIsland Consulting Ltd,
to act as our agent in relation to our building consent
application at the Whanganui District Council.

Jane Exmoor J Exmoor
ph 0220 1291140

JAN MORRELL JMRMorrell
ph 021 126 9959

Wood Fire Installation & Owner's Operation Manual



metrofires

Insert Wood Fires

Important information.....	2	Operating your Metro	11
Assembling your Metro.....	2	Cleaning and maintenance	11
Floor protector requirements	5	Troubleshooting	13
Installing your Metro.....	6	Metro warranty.....	14
Wetback installation	7	Replacement parts & accessories.....	15
Getting to know your Metro.....	9		

WARNING! Important Information

- **WE HIGHLY RECOMMEND YOU READ THIS ENTIRE MANUAL AS INCORRECT OPERATION, MISUSE AND/OR LACK OF MAINTENANCE WILL VOID THE WARRANTY**
- The appliance and flue-system shall be installed in accordance with AS/NZS2918 and the appropriate requirements of the relevant building code or codes
- Any modification of the appliance that has not been approved in writing by the testing authority is considered to be in breach of the approval granted for compliance with AS/NZS4013 and will void the warranty
- The appliance must be installed correctly. We recommend a competent and suitably qualified NZHHA installer

CAUTION! Important Information

- Mixing of appliance or flue-system components from different sources or modifying the dimensional specification or components may result in hazardous conditions. Where such action is considered, the manufacturer should be consulted in the first instance
- Do not install a Metro fire if there is any sign of visible damage to the product
- This appliance must be regularly maintained.
- Use authorised Metro replacement parts only. The use of unauthorised parts may void the warranty
- This manual **MUST** be left with the home owner

Metro insert fires are tested to comply with AS/NZS 2918:2001 incorporating Appendix 'E' when installed in accordance with this manual. Please ensure you are fully conversant with this relevant standard and the contents of this manual. Correct installation is critical to the safe operation and performance of this wood fire.

Please take particular note of the following:

- ECO Metro's should be installed with a Metro ECO flue system which has been developed to enhance the performance of Metro wood fires. A minimum length of 4.1 metres of 150mm diameter is required. Any alternative flue system must have a minimum flue pipe length of 4.1 metres of 150mm diameter flue pipe & have been tested to AS/NZS2918:2001
- All flue joints must be sealed and riveted in three points with stainless steel or monel rivets; the bottom of the flue in particular **MUST** be fully sealed into the flue outlet of the Metro wood fire and secured with the bolt & nut as supplied in the component kit

- The 150mm flue pipe must be fully encased to the underneath of the flashing cone, from above the chimney breast. (there must not be any 150mm flue pipe exposed)
- Ensure a fibreglass seal is placed between the outer cabinet and the masonry to prevent air from within the room being drawn into the chimney cavity
- In New Zealand, the Metro Insert must be bolted securely to the base of the chimney cavity to comply with the seismic restraint provisions of AS/NZS2918.2001
- The Trend fascia is coated in vitreous enamel and the Smart fascia is available in both vitreous enamel and metallic black high temperature paint finish. Take care during assembly and when lifting and fitting the fascia that you do not damage the vitreous enamel coating. Any surface damage to the paint finish Smart fascia can be repaired with the use of Pioneer high temperature paint.
- **DO NOT** lift the Insert fascia with your fingers under the louvre's.

Assembling your Metro wood fire

All Metro Insert wood fires are packed in two heavy-duty cartons. The Insert firebox is supplied in a heavy duty palletised carton, this carton is clearly labelled. The fascia and door are packaged inside a smaller separate carton. This carton is also clearly labelled to show the colour and coating finish of the fascia and door. Metro fascia's are coated in either vitreous enamel or high temperature paint. Having removed the packaging and located this manual, familiarise yourself with the diagrams on pages 3 & 4, and proceed as detailed.

Note: The Metro carton shows the model Metro you are about to install, enabling you to select the appropriate model's assembly instructions.

ECO Insert Fan (ECO Trend Insert model only)

In all clean air zones, the Metro ECO Trend Insert must be installed with Metro's ECO Insert fan which is a single speed, thermostatically controlled device. This fan must be permanently wired and therefore requires the services of a registered electrician. Fitting instructions for the fan are supplied with the fan module

Pre installation - Firebox cavity

Prior to installing your Metro insert firebox into a fireplace cavity, it is important that specified clearances and other requirements are complied with as follows:

- The chimney must be swept and checked for cracks and general overall condition. If repairs are necessary, they must be carried out by a suitably qualified person
- Check the cavity dimensions to ensure the fireplace insert will fit. It is usually necessary to remove fire bricks from the lower fireplace cavity
- The base of the fireplace cavity on which the Metro fireplace insert will rest must be level. If it is not, it should be levelled using mortar
- If an ash removal door exists in the base of the fireplace cavity it should be sealed shut to prevent air entering the cavity
- If a timber or combustible mantelshelf exists above the fireplace opening, it should be a minimum distance above the top of the Metro's fascia. If less than the minimum specified, a deflector or heat shield will be required to be fitted under the mantelshelf or to the top of the fascia using the relevant detail as set out in AS/NZS 2918:2001. Mantle clearances are detailed on page 5.

Assembling your Metro wood fire

Metro Insert firebox

- Remove from within the firebox the plastic bag containing the bolt kit, two firebricks wrapped in a cardboard wrapper and then the top baffle assembly
- A 'spacer' washer has been pre-fitted and taped to the top door hinge pin on the left hand side of the firebox (Refer Inset A) remove this tape
- Remove the 'cabinet top' which is packed inverted on top of the firebox and fit it into position over the cabinet sides as detailed in Diagram 1. Ensure the rear edge is fitted correctly as shown Diagram 1, Inset 'B', the rear edge of the cabinet top must fit into the slot provided. Lift the front to the highest available position and using two of the self tapping screws from the plastic bag, secure the cabinet top in place taking care to not damage the insulation blanket.

Note: This panel can be fitted at two height's. If the height of the fireplace opening will allow, fit the cabinet top in the higher position, fit screws from inside the cabinet facing out.

- Ensure the insulating blanket is in position on the top of the cabinet and remains in a sound condition
- Remove the four speed clip nuts from the plastic bag and fit them to the holes provided in the front edge of the cabinet as shown in Diagrams 1 and 1A
- Next you need to fit the top baffle.

All insert models feature a two piece top baffle which locates onto six lugs provided on the side walls of the firebox's upper chamber, as detailed in Diagram 2 on page 4. The rear baffle section is 6mm folded steel and has a central locating pin fitted to its front top surface. Fit this rear baffle through the door opening and into position in the upper chamber of the firebox. It is supported on the rear four support lugs and must be hard back against the rear wall of the firebox with the central locating pin facing up and towards the front.

Next, locate the front baffle which is a combination baffle comprising of a 6mm steel plate with a promet (white board) front extension. Fit this baffle through the door opening and into position, ensuring the hole provided on its rear edge is positioned over the locating pin fitted to the rear baffle.

Unwrap the two firebricks from the cardboard wrapper and fit the side bricks to each side of the firebox. Location lugs are fitted to the base and rear of the firebox to retain the side bricks in position, refer to the relevant Diagram 2 on page 4.

Diagram 1 - ECO & LTD Insert Firebox

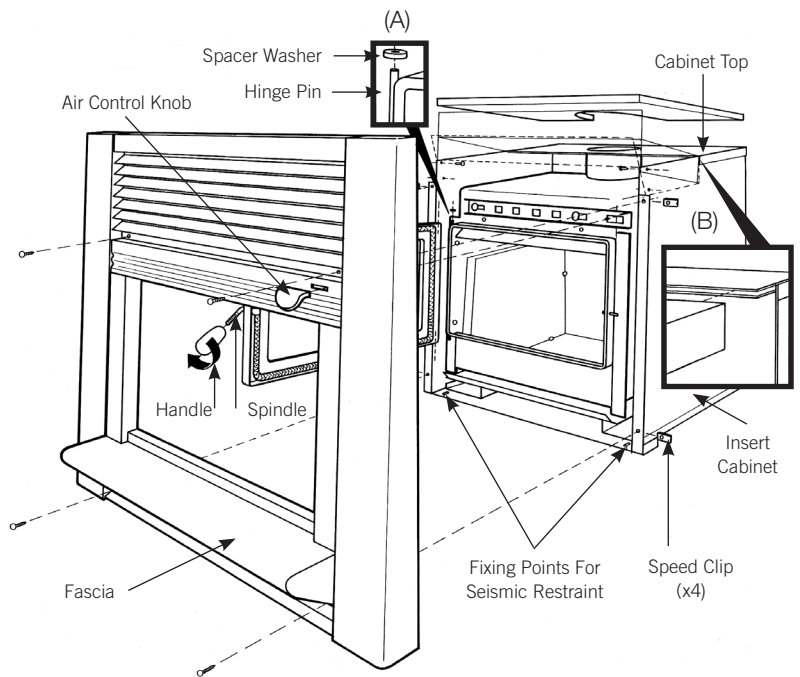
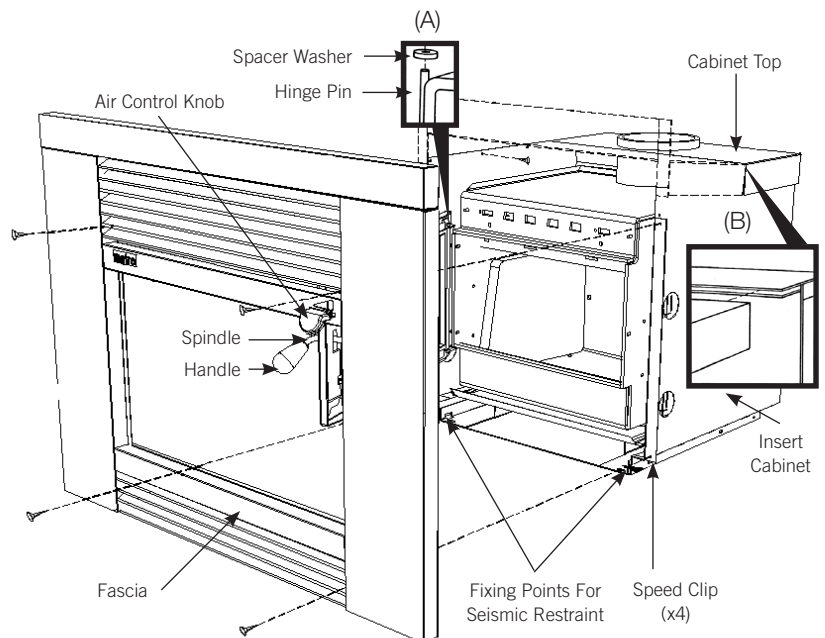
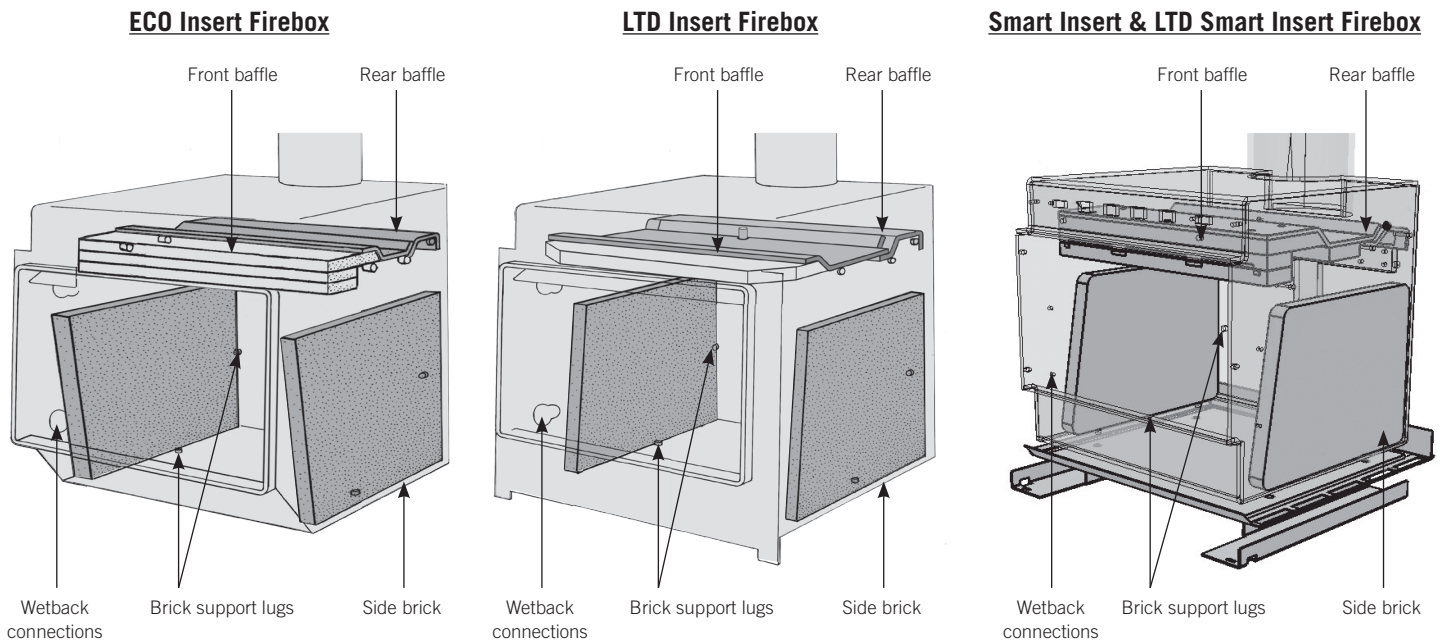

Diagram 1A - Smart Insert & LTD Smart Insert Firebox



Assembling your Metro wood fire

Diagram 2 - Firebox brick and baffle locations



Assembling the fascia (Trend Insert models only)

Trend fascia's are supplied partly assembled, and require the ashlip and bottom louvre to be fitted as illustrated in Diagrams 3 and 3A below. To assemble, proceed as follows: -

- On a large flat, clean and soft surface (carpet floor) slide the fascia out of the carton, front face down and remove the door which is packed into a separate carton located in the centre of the fascia. Close the flaps of the fascia carton and lay the fascia front down on top of this now empty carton
- Remove the two sections of tape securing the ashlip panel to the rear face of the fascia as detailed in Diagram 3. Carefully lift the ashlip panel away from the fascia and place it gently to one side
- Remove the four screw's and bottom louvre as illustrated in Diagram 3.

- Reposition the ashlip into its final position as illustrated in Diagram 3A taking particular attention to ensure:
 - The ashlip is the right way around
 - Do not mark the coating on the ends of the ashlip panel as you slide it into the fascia, you may need to slightly prise apart the fascia side panels as you fit the ashlip.
- Position the bottom louvre as illustrated in Diagram 3A and refit the four screws previously removed.

The fascia is now completely assembled and ready for installation. When moving the fascia, hold it at both sides to avoid 'twisting' the fascia which may cause the enamel to chip.

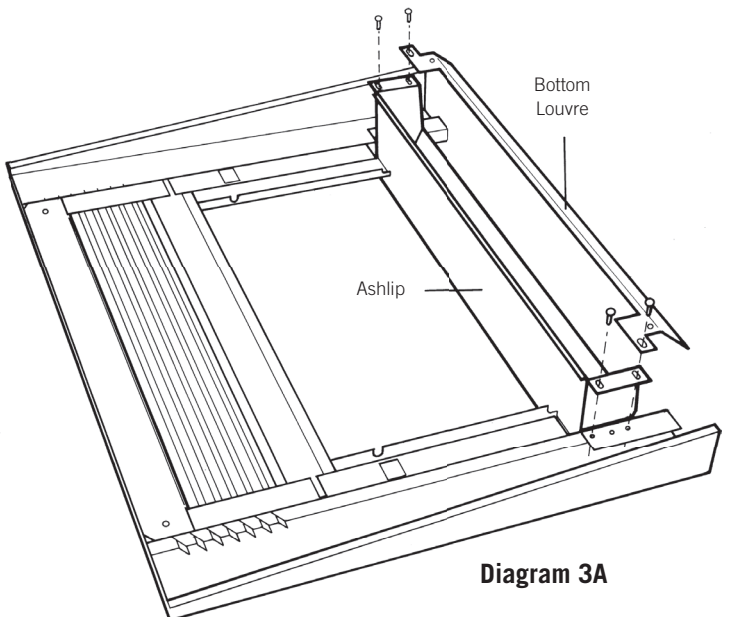
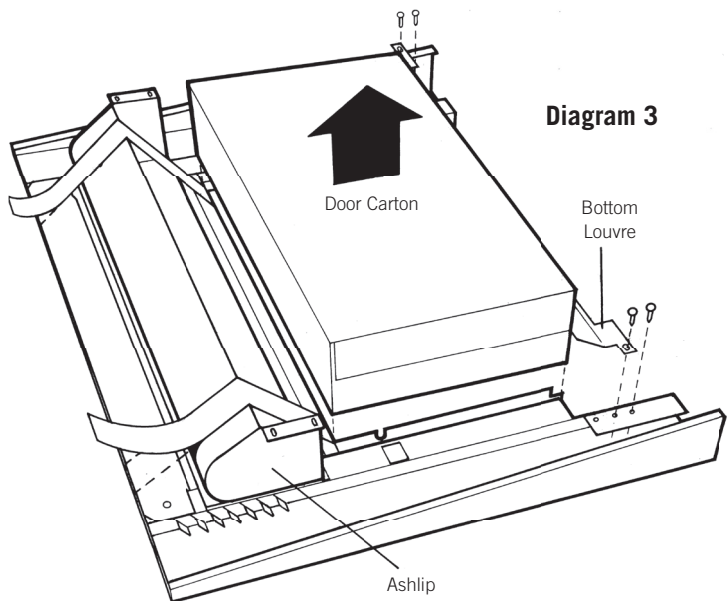

Floor protector requirements

Floor protector requirements

Metro fireplace inserts are designed to be installed directly onto a concrete base. The floor protector is required to project in front of the Metro and must extend a minimum of 200mm to each side of the door opening making the minimum floor protector width 825mm.

The floor protector must project from behind the fascia the distance specified (I) in the table below. Minimum projection is the distance from the front of the wall lining (behind the fascia) to the front non combustible point of the floor protector.

ECO Trend Insert

On properties less than 2 hectares, the ECO Trend Insert must be installed with the single speed Metro thermo fan.

The ECO Trend Insert requires an ash-hearth floor protector with recommended construction of tiles on 6mm thick non combustible board. The minimum floor protector projection forward of the Metro is 300mm as detailed in the table below. Any non-combustible material fixed directly to a combustible floor is acceptable.

LTD Trend Insert

The LTD Trend Insert requires an insulating floor protector. The forward projection is dependent on the height of the fireplace insert above the combustible floor. The schedule of projections listed for heights of 0mm to 41mm+ can be achieved by the thickness of the floor protector, raising the Insert or a combination of the two. Recommended construction is tiled eterpan with a combined thickness as detailed in the table below.

Smart Insert

The ECO Smart Insert requires an insulating floor protector with recommended construction of tiles on 26mm thick eterpan or alternative insulating material of equivalent insulation properties. The forward projection detailed below (I) is dependent on the height of the fireplace insert above the combustible floor.

LTD Smart Insert

The LTD Smart Insert requires an insulating floor protector with recommended construction of tiles on 26mm thick eterpan or alternative insulating material of equivalent insulation properties. The forward projection detailed below (I) is dependent on the height of the fireplace insert above the combustible floor.

Mantel clearance

A timber or combustible mantel shelf above the fireplace Insert opening should be a minimum distance (L) above the top of the Metro's fascia as detailed in the table below. If the clearance is less than the minimum specified, a deflector or heat shield will be required to be fitted under the mantelshelf or to the top of the fascia using the relevant detail as set out in AS/NZS 2918:2001.

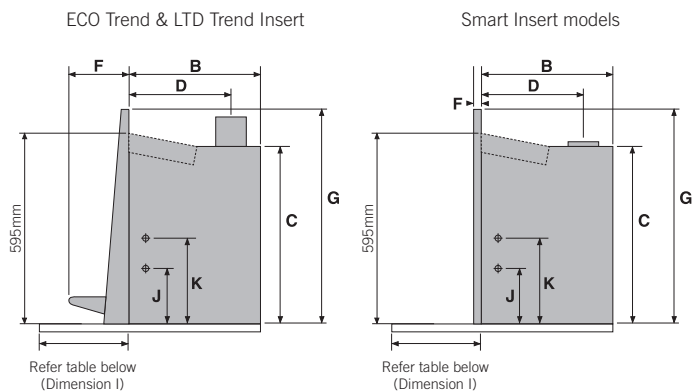

	Firebox Width	Firebox Depth	Firebox Height	Flue Centre	Fascia Width	Fascia Depth	Fascia Height	Minimum Floor Protector Width	Minimum Floor Protector Projection	Wetback In	Wetback Out	Mantel clearance
Insert & Built-In Dimensions (mm)	A	B	C	D	E	F	G	H	I	J	K	L
ECO Trend Insert	560	500	550	405	810	185	650	825	300	170	360	340
LTD Trend Insert	560	500	550	405	810	185	650	825	350	170	360	460
Smart Insert	560	495	550	405	890	30	672	825	312	130	325	475
LTD Smart Insert	560	495	550	405	890	30	672	825	312	130	325	475

Please note: All measurements detailed above exclude the 13mm insulating blanket.

Floor Protector Heights	0mm	10mm	15mm	20mm	25mm	30mm	35mm	40mm	41mm+
ECO Trend Insert - DIMENSION I	300mm minimum projection is required irrespective of the height of the floor protector								
LTD Trend Insert - DIMENSION I	455mm	455mm	445mm	436mm	424mm	408mm	396mm	366mm	350mm
Smart Insert - DIMENSION I	395mm	371mm	371mm	353mm	353mm	332mm	332mm	312mm	312mm
LTD Smart Insert - DIMENSION I	395mm	371mm	371mm	353mm	353mm	332mm	332mm	312mm	312mm

Installation

Position the Metro Insert firebox which is still attached to its wooden pallet directly in front of the fireplace cavity with the rear of the insert facing the fireplace opening. The fireplace insert assembly is bolted to the wooden pallet through its base panel at two points being each front corner. Remove both screws and slide the insert into the fireplace cavity taking care not to mark the floor protector. Discard the pallet.

1. Attach the fascia with the four longer screws that were supplied in the plastic bag, taking care that the air control lever passes through the slot provided in the fascia. Centralise and level the fascia on the fireplace insert door and secure the four screws.
2. Applying pressure to the fireplace firebox (not the fascia) carefully manoeuvre the Metro until the rear of the fascia is just touching the front face of the fireplace surround. Taking care not to move the fireplace insert, remove the fascia and mark the position of the fireplace insert onto the fireplace base.
3. Using a masonry drill, drill into the chimney base through the two slots which the fireplace insert was secured to the pallet through. Check to ensure the fireplace insert hasn't moved and secure using suitable masonry anchors to comply with the seismic restraint provisions of the standard.
4. Check that the flue stub of the fireplace insert is in line by looking down the chimney, if not a stainless steel offset or flexi flue will be required.
5. Following the instruction sheet supplied with the flue system, proceed and fit the flue with ALL JOINTS SEALED and riveted with a minimum of three stainless steel or monel rivets on each joint.
6. With the flue pipe in position and sealed with a high temperature fire cement into the flue stub, drill through the hole provided in the front of the flue stub into the stainless steel flue pipe and secure with the 6mm bolt and nut supplied in the plastic bag.
7. Refit the top baffle into the firebox's upper chamber. Support by the steel plates only and keep the baffle horizontal.
8. Using a suitable rated insulation (fibretex 450 or similar) pack any gap that exists between the sides and top of the fireplace insert cabinet and fireplace surround. Do NOT block off the lower convection slots on all three sides in the base of the outer wrap. (ECO Smart Insert model).
9. If installing into a clean air zone, the Metro ECO Insert firebox must be installed with Metro's ECO Insert fan as detailed on page 2. Installation and wiring of this fan module is necessary prior to fitting the fascia, and full fitting instructions are supplied with the fan module.
10. Take the door you previously removed from the centre of the fascia and unpack it. Taking the door in both hands with the spindle end in your right hand and outer face of the door facing you, attach the door to the firebox as follows: -
 - With the door in a 45 degrees open position, allow the lower hinge pin on the bottom left hand side of the firebox to pass into the hole provided in the bottom of the door frame
 - Lift the door until the top of the door frame passes over the top hinge pin, then align the hole provided on the top face of the door frame and lower it down over the top hinge pin
 - Take the door handle from the plastic bag and screw it onto the door spindle by turning it clockwise
11. Re-attach the fascia, centralise and level with the door and ensure the air control is moving freely and secure all four screws.
12. Locate the air control knob which is included in the plastic bag and carefully work it onto the air control lever.

The Metro is now fully installed and ready for operation but it is preferable to defer lighting the fire for a day or two if possible to allow sealant used in the flue pipe joints to air dry. Alternatively it is recommended you burn 2-3 sheets of loosely crumpled newspaper at a time, approx once every hour over a 6-8 hour period.

Wetback installation

WARNING! Important Information

- **DO NOT** connect to an unvented hot water system
- Install in accordance with AS 3500.4.1 or NZS 4603 and the appropriate requirements of the relevant building code or codes.

CAUTION! Important Information

- Fitting the water heater is best performed prior to installing the Insert firebox into the fireplace cavity
- Wetbacks must be connected with water before operating the fire and available to the wetback while the fire is in operation
- Wetback systems are not suitable for use in locations where the water supply has lime content. Lime build up inside the coil will eventually block the coil causing the wetback to fail. This is not covered under warranty
- Rainwater collection tanks installed lower than the wetback that use a water pump to supply the home, can cause problems if the pump is not operational. In these situations either the type of wetback or a roof header tank should be considered
- The Metro ECO Trend Insert is not approved with a wetback in a clean air zone but can be installed with either Pioneer's 3kW or 4kW wetback option on properties of 2 hectares or greater.

Wetback	Suitable for models:
Smart Booster 	<ul style="list-style-type: none"> • Smart Insert • LTD Smart Insert
3kW Wetback 	<ul style="list-style-type: none"> • ECO Trend Insert (properties of 2Ha+ only) • LTD Trend Insert
4kW Wetback 	<ul style="list-style-type: none"> • ECO Trend Insert (properties of 2Ha+ only) • LTD Trend Insert

Water heating is another key feature of your Metro Insert wood fire; all Metro Insert models can be fitted with a wetback, which are designed to give maximum output with minimal effect on the operation of the fire. Only the Pioneer cast jacket wetback system should be fitted to your Metro; alternative wetbacks will void the Metro's emission approvals and may seriously affect the performance of the appliance and void its warranty.

All Insert model wetbacks can be fitted to either side of the firebox, with the connection pipe heights detailed in the table below.

It is recommended the return pipe has a minimum rise of 1 in 12; performance will reduce as the distance to the storage cylinder increases.

Wetback installation for the ECO and LTD Trend Insert

The Metro ECO Trend Insert is not approved with a wetback in a clean air zone but can be installed with either Pioneer's 3kW or 4kW wetback option on properties of 2 hectares or greater.

Pioneer's 3kW and 4kW wetback options are fitted internally to either side of the ECO Insert firebox and LTD Insert firebox.

To fit the 3kW or 4kW wetback proceed as follows

1. Remove the brick from the inside of the firebox from the side the wetback is to be fitted too.
2. Expose the holes in the firebox wall through which the connection pipes will pass.

The ECO and LTD Insert fireboxes have 3mm pressed washers covering these two openings and two 6mm bolts which are fitted inside the firebox near the connection holes, remove these also.
3. Using a hole saw or snips, prepare the cabinet for the connection pipes. Note, these holes should be a neat fit or have any excess gap covered or filled with high temperature insulation.
4. Using the tube of sealant supplied with the wetback, apply a liberal bead of sealant around both connection holes on the inside of the firebox. On the rear of the wetback casting apply the remaining contents of the tube equally around both connection pipes and also the outer circumference of the wetback which will face the inside rear wall of the firebox. This will completely seal the wetback to the inside rear wall of the fire on installation.
5. Fit the wetback into the firebox and position the connection pipes through the connection holes in the firebox.
6. Fit two bolts through the slots provided in the wetback, align the wetback so its front edge is parallel to the door opening and secure the bolts.
7. The wetback is now ready for connection to the storage cylinder by a registered plumber.

Wetback installation

Wetback installation for the Smart Insert & LTD Smart Insert

The Smart Insert water heater comes fully assembled and is designed to be fitted to the outside face of either the left or right hand side of the firebox.

Note: The hot water output of this water heating device is dependent on correct installation and the proximity of the Smart Insert to the hot water storage cylinder.

To fit the Smart booster proceed as follows

- The closer the Smart Insert is to the hot water storage cylinder, the greater the hot water production will be, and generally distances over 3 metres are not recommended
 - The return hot water connection copper pipe must be insulated and have a minimum rise of 1 in 12 along its entire length. 1 in 12 is minimum and the greater the rise the better the performance
 - The return hot water pipe must be connected to the riser pipe connection in the base of the hot water storage cylinder.
1. Remove the fascia (if fitted), then on the side of the firebox to which the water heater is to be fitted, remove the angle cover plate from the inside face of the outer cabinet. Also, remove the fire brick on the wetback side from inside the fire box.
 2. Having removed this cover plate the front face of the inner wrap is exposed. Fold the front face of the inner wrap outwards so it is parallel with the outer cabinet. This is needed to create access for the water heater to fit between the firebox and the inner wrap.
 3. Remove the two square knock out plates from the front face of the inner wrap to provide clearance for the two connection pipes when the return is folded back.
 4. Remove the two 50mm diameter knock out plates from the outer cabinet.
 5. With a long handled 10mm set spanner, reach in between the inner wrap and the firebox and loosen the nut on the rear Pozi drive screw which will be used to secure the water heater. Then unscrew from the inside and discard the 6mm nut as the screw will thread directly into the water heater casting. Repeat for the two front bolts but retain the nuts and washers.
 6. Remove the water heater from its box, which also contains a tube of fire cement. You will note a 6mm bolt and washer is fitted to one of the casting ribs, remove this.
 7. Smear a "liberal but even" amount of Pioneer fire cement over the entire 'flat face' of the water heater in order to ensure full surface contact with the outside face of the firebox.
 8. Hold the hot water heater by the two copper pipes and slide the water heater between the inner wrap and the firebox until the pipes are vertical and in line with the two 50mm holes in the outer cabinet. The pipes will be tight against the outer cabinet as you do this, but the cabinet will flex enough to allow you to work the device until the pipes pass through the 2 x 50mm holes in the outer cabinet.
 9. Re-fit one of the bolts previously removed (stage 5) from inside the firebox through one of the two slots provided in the front edge of the water heater casting, and loosely attach the washer and nut to the thread of the bolt.
 10. Next pivot the water heater using the first bolt just refitted as a pivot point, and refit the rear pozi drive screw from inside the firebox into the rear tapped hole in the casting. Then refit the remaining front bolt and attach the washer and nut.
 11. Fully tighten all three fastenings, and check to ensure the casting has pulled up evenly onto the side of the firebox. Excess fire cement should be visible around the entire perimeter of the casting.
 12. Bend the front returns of the inner wrap back into place so it folds around the front of the water heater, then secure the inner wrap to the casting by refitting the 6mm bolt and washer previously removed at stage 6.
 13. The water heater is now ready to have the copper pipe work attached for connection to the hot water storage cylinder (brazed joints are recommended)
 14. Once all joints have been thoroughly checked and tested for leaks, refit the angle cover plate removed at stage 1, then align and refit the fascia. Both side bricks must be fitted inside the firebox.

⚠ WARNING! Important Information

- **WE HIGHLY RECOMMEND YOU READ THIS ENTIRE MANUAL AS INCORRECT OPERATION, MISUSE AND/OR LACK OF MAINTENANCE WILL VOID THE WARRANTY**
- Any modification of the appliance that has not been approved in writing by the testing authority is considered as breaching AS/NZS 4013 and will void the warranty
- Do not use flammable liquids or aerosols in the vicinity of this appliance when it is operating
- Do not dry clothes on or near this appliance
- Do not use flammable liquids or aerosols to start or rekindle the fire OR store fuel within the Metro's specified installation clearances
- Never operate your Metro with the door ajar, except on initial start up
- Open the air control fully before opening the Metro's door.

⚠ CAUTION! Important Information

- This appliance should be maintained & operated at all times in accordance with this instruction manual
- This appliance should not be operated with cracked door glass, over worn, faulty or missing door seals
- Do not use driftwood, treated or unseasoned (wet) fuel, the use of most types of preservative treated wood as fuel can be hazardous and will damage your appliance
- Burning unseasoned (wet) fuel or incorrect operation on extended low burn cycles will cause excessive creosote to form. Creosote is very corrosive and excessive buildups will result in the flue pipe, flue spigot and upper burn chamber failing. Failure of the appliance and/or flue system due to creosote damage is not covered under warranty. The formation of such is not an appliance issue it is a fuel and operational issue
- This appliance must be regularly maintained and replacement parts must be authorised Metro parts only
- Do not empty ash into a combustible container.

Congratulations on the purchase of your Metro wood fire

This slow combustion appliance is designed to give you many years of warmth and service, subject to the following key factors. These key factors, if not adhered to are the major causes of unsafe installation, poor performance and flue blockages and potential product failure.

1. Your Metro wood fire must be installed correctly. Metro recommend a competent and suitably qualified NZHHA installer.
2. The only fuel to be used in this appliance shall be wood that meets the following criteria.
 - Less than 25% moisture content
 - Has not been treated with preservatives or impregnated with chemicals or glue,
 - Is not chipboard, particle board, or laminated board,
 - Is not painted, stained or oiled
 - Is not driftwood or other salt impregnated wood
3. The appliance shall be operated at all times in accordance with the 'Installation and Operating Instructions' supplied with each appliance.
4. It is preferable that Metro wood fires should be installed with a Metro ECO Flue System.
5. Coal must not be used as a fuel.

Please also note the following important points:

- In New Zealand a building consent is required from your local building authority. The homeowner is responsible for obtaining this consent
- As correct installation is critical to the performance and safe operation of your Metro, it is recommended your Metro be installed by a NZHHA registered installer or a person suitably qualified in the installation of wood fires. Your Metro retailer will be able to arrange professional installation for you
- During the very first fire your Metro will give off an odour and fumes as the firebox paint cures. Do not be alarmed; open all windows and externally opening doors in that room and close any internally opening doors. This curing process will last for approximately one hour and is likely to happen this one time

- Properly seasoned (dry) timber is necessary for the Metro to operate efficiently; firewood that contains a high moisture content will result in flue pipe blockages, reduce heat output and create other issues.

Note: Once split, Softwood usually takes 12 months to season - Hardwood can take up to 24 months to season - Wood must be stored in a location that enables air circulation. Unseasoned wood stored in a closed woodshed without air circulation will still be unseasoned 12 months later.

- It is critical that the fire not be operated with over worn, faulty or missing door seals. Door seals will harden over time and become over-worn (3-4 year's) this will cause air to leak into the fire, causing the appliance to 'over fire'
- It is critical that the fire not be operated with over worn, faulty or missing bricks, baffle plate, promet extension (white board on the baffle plate)
- It is critical that the fire not be operated with cracked or broken door glass.

Please note, the above 3 points require regular inspection/maintenance (every time the ash bed is cleaned out, generally 3-5 times a season) and if not maintained will void the firebox warranty. A glowing firebox or lower fluepipe is just one sign you are over firing your appliance. Please ensure you keep your proof of purchase/receipt on any parts you purchase.

- A key feature of all LTD Metro's is their ability to burn at a very low rate. To familiarise yourself with correct operation of this feature, please ensure you read the "extended burning" section on page 11 of this manual so as not to void the Metro warranty by incorrect operation
- For optimum performance fuel must be loaded so the logs lay "front to rear" in preference to laying across the width of the firebox. Spaces should be left between the logs to enable oxygen to get to as much of the surface of the fuel as possible
- A small hot fire loaded frequently is more efficient than a large fire burning on a low setting
- Your Metro is covered by a full unconditional 12 month warranty on replacement parts, and a 10 year firebox warranty.

Optional wetbacks

Water heating is another key feature of your Metro wood fire; nearly all Metro models can be fitted with a wetback, which are designed to give maximum output with minimal effect on the operation of the fire. Only the Pioneer cast jacket wetback system should be fitted to your Metro; alternative wetbacks will void the Metro's emission approvals and may seriously affect the performance of the appliance and void its warranty.

If your home is in a classified 'clean air zone', and dependent on requirements/restrictions which may be imposed by your local territorial authority (council) you may or may not be able to install a water heating device. If in doubt consult your local Metro retailer.

Other considerations are:

- Distance from your Metro to the storage cylinder will affect the amount of hot water produced
- Your climate & the manner in which you will 'fire' your Metro will determine the amount of hot water produced.



Note: Wetbacks are not suitable for use in locations where the water supply has lime content. Lime build up inside the coil will eventually block the coil causing the wetback to fail.

Cost Savings

Wetbacks can enable substantial power savings, dependent on the climate in the area in which you live. If you live in a cold climate you are likely to use your Metro for many months of the year, in which case a Pioneer wetback will reduce or even eliminate your water heating costs over those months. If however you live in a warmer climate and use your Metro for only a few hours a day over the colder months, electricity savings will be considerably less.

Water Pressure

A common misconception is that you must have a low-pressure system to have a wetback; this is not true. You must have a 'vented' system and high-pressure cylinders are usually not vented. However you can install an 'indirect' cylinder which contains a secondary coil inside the storage cylinder, enabling you to have a wetback while retaining a high-pressure system.

Wetback	Suitable for models:
 <p>Smart Booster</p>	<ul style="list-style-type: none"> • Smart Insert • LTD Smart Insert
 <p>3kW Wetback</p>	<ul style="list-style-type: none"> • ECO Trend Insert (properties of 2Ha+ only) • LTD Trend Insert
 <p>4kW Wetback</p>	<ul style="list-style-type: none"> • ECO Trend Insert (properties of 2Ha+ only) • LTD Trend Insert

Getting to know your Metro wood fire

Operating your Metro fire is simple and you will quickly learn how to get the best from it. First take a minute to familiarise yourself with your new Metro.

- Raise the door handle anti-clockwise until the latch releases, and then slowly pull the door open. You will note that if you let the door go before it is at 90° to the appliance, it will fall closed. This is a safety feature that ensures the door cannot fall open if it is not latched securely. For the door to remain open, you must open it fully
- There is a single air control making your Metro fire easy to adjust. This control moves from left to right, which is 'low to high'.

All Metro insert fires have an air control knob located directly above and to the right of the door. Slide this control knob gently from right to left until you reach a stop, this is a preset 'low' position. Your Metro must not be operated at a lower burn rate than this pre-set low allows.

Please note: The Metro LTD Trend Insert model enables you to have total control of burn rate from 'high' to 'off'.

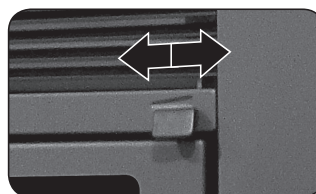

Metro Insert air control

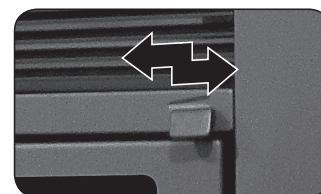

LTD Trend Insert - Safety off provision

Safety off provision

The LTD Trend Insert model has a safety 'off' provision which enables the air control to be fully closed during flue pipe cleaning, and more importantly to enable all primary oxygen to the fire to be cut off in the unlikely event of a flue pipe fire. To engage the 'off' provision, lift the air control knob up and move it fully to the left.

Operating your Metro wood fire

If your Metro has only been installed within the past few days, the fire cement seal at the base of the flue will not be fully cured. To ensure the cement sets without blistering it is recommended you burn 2-3 sheets of loosely crumpled newspaper at a time, approximately once every hour over a 6-8 hour period.

During the very first fire your Metro will give off an odour and fumes as the firebox paint cures. Do not be alarmed. Open all windows and externally opening doors in that room and close any internally opening doors. This curing process will last for approximately one hour and is likely to happen this one time.

Start up

Place a quantity of loosely crumpled newspaper on the base of the firebox until it is approximately half full of paper, or place firelighters on the base of the firebox. Add dry kindling and move the air control knob fully to the right, being the "full open" position.

Light the paper at two or three locations across the front of the door opening and leave the door slightly ajar resting on the latch pin if necessary for a few minutes while the fire establishes. Once the kindling is burning well, open the door and add 2-3 small logs at a time until you have a well-established fire. Usually this will take approximately 30 minutes, during which time the air control should be set on "high" and the door should be closed, except for the initial few minutes and when fuel is being added.

Normal operation

Once the fire is well established, regulate the air control to achieve the desired burn rate and heat output. As you move the air control to the right, burn rate, firebox temperature and heat output will increase, if you move the control to the left they will decrease. Please note:

- Always open the air control fully prior to opening the door, then open the door slowly. Every time you refuel, leave the air control on 'high' for a minimum of 20-25 minutes

- When loading logs, place them end-on, 'front to back'; air spaces should be left between the logs to enable oxygen to get to as much of the surface of the fuel as possible
- Never use the door to force wood into the firebox, as this is likely to break the glass.

Extended burning (rural models only)

It is most important if your Metro is to be refuelled and turned down for an extended period, such as an overnight burn that you operate it correctly:

- The wood used as fuel for extended burning **MUST BE FULLY SEASONED (DRY)**. Once the fuel is loaded, the appliance must be operated on high for a period of at least 20 minutes to drive out residual moisture from the fuel (dry wood is usually 20% water content) and ensure surface area combustion.
- Do not turn the air control down lower than you need to, if you want the Metro to burn overnight, endeavour to obtain an 8 hour burn time, not 12 hours. It will take a few burns to find the correct location of your Metro's air control setting to achieve the length of burn cycle you desire as this setting is affected by several variables including fuel density, flue length and outside wind velocity.
- A smouldering fire over a long time frame is likely to deposit corrosive elements into your system which could be detrimental to your Metro.

CAUTION! Important Information

- If not operated correctly on extended burn cycles, your Metro is likely to incur flue blockages, corrosion of the upper baffle, lower flue pipe and firebox flue spigot. As these are not covered under warranty if they fail through improper use, it is important you operate your Metro correctly.

Cleaning and maintenance for your Metro wood fire

Your Metro fire will give you many years of efficient service with minimal maintenance if operated correctly using seasoned fuel. Your Metro fire must be regularly maintained and replacement parts must be authorised Metro fires parts only.

Metro Insert fascias

The front panelling of your Metro insert fires fascia will be coated with one of two coating systems, which can be cleaned with a soft cloth when the Metro is not operating. The two alternative coating systems used on Metro insert fascias are:

- Vitreous enamel which is extremely durable and designed to last the life of the appliance. As vitreous enamel is glass, a solid or heavy object dropped or banged against a panel could chip the enamel surface.
- High temperature paint finish which will require periodic repainting to keep it looking its best. This coating is not as durable as vitreous enamel and is susceptible to scratching, so care is required. Fascias coated with high temperature paint can be easily resprayed using Pioneer metallic black paint.

Door glass

Providing your fuel is properly seasoned, under normal operating conditions the air-wash design of the Metro's firebox will keep the door glass clear. If the glass requires cleaning you may use either a razor blade scraper or crumpled wetted newspaper dipped in wood ash rubbed over the glass.

If your door glass breaks it must be replaced with 5mm thick ceramic glass which is available from your local Metro retailer.

Door seals

Over time, usually 3-4 years, the door and glass seals will become hard and cause air to leak into the firebox, causing the appliance to 'over fire'. Your Metro retailer stocks replacement woven fibreglass door and glass seals, which need replacing when they become hard and over worn.

The door of your Metro is easily removed. Hold it in both hands and lift the hinge end of the door up and over the top hinge pin, then lower the door from the bottom hinge pin.

Cleaning and maintenance for your Metro wood fire - continued

Side bricks

Hair-line cracks are not uncommon and are a result of the intense heat within the Metro's firebox, coupled with mechanical damage caused by accidental impact when fuel is being loaded. However if the side bricks become cracked to the extent that they start to break up, they must be replaced.

Door adjustment

Provision is available on both sides of the door for adjustment.

To adjust the hinge end of the door, open the door fully, loosen the top hinge nut and slightly lift the latch end of the door; you will see the hinge assembly move back 1-2mm which will usually be sufficient. Retighten, then repeat by loosening the lower hinge nut, this time applying a slight downwards pressure onto the door to move the lower hinge assembly back a similar distance, then retighten.

The door latch is also adjustable, as the latch pin on the right side of the firebox is fitted through a slot which enables the latch pin to be loosened, moved back and re-tightened.

Ash removal

Over a period of time ash will build up in the base of the Metro's firebox and require removal. The time this build-up takes depends on the density and cleanliness of your fuel.

To remove the excess ash your Metro should not be operating.

- Open the door, and using a hearth shovel or similar, empty the excess ash directly into a steel or non-combustible container.
- If the ash is not disposed of immediately, be careful where you store it, as the ash can retain heat for many days and become a fire hazard.
- You must leave a bed of ash in the base of the firebox approximately 10mm deep; this insulates the base of the firebox and improves combustion.

Top baffle

Your Metro Insert fire has a secondary burn chamber which enables it to operate at very high efficiency's. This secondary burn chamber is created by the top baffle which is illustrated on the page 4 of this manual.

This is a 'sacrificial' wear part of the firebox and should be checked monthly. Usually only the promet (white board) front/underneath section needs to be replaced when it starts to disintegrate.

To remove and replace your Metro's top baffle, proceed as follows: -

- Open the Metro's door fully, reach inside with the palm of your hand face up and extended, lift the top baffle approximately 20mm, then lift it forward out through the door opening placing it on a sheet of newspaper you have placed on the front of the hearth. Please Note: -
- Your Metro Insert fire has a two piece baffle as illustrated on page 4. The rear baffle section also lifts 'up and out' the same as the front baffle.
- If your Metro Insert fire is fitted with an internal wetback, to remove the baffle you will need to remove the fire brick from the opposite side of the firebox. Then lift the baffle slightly and slide it forward 30mm, allowing the rear edge of the baffle to drop down in front of the rear support lugs on the side of the firebox you have just removed the brick from. The baffle can then be easily removed through the door opening.

- To refit the top baffle. Proceed in the reverse order and note, the baffle must be fitted so its rear is touching the back of the firebox.

Note: Cracks in the promet are not uncommon and have no adverse effect on the operation of your Metro. These cracks are the result of intense heat coupled with expansion and contraction. Burning wood which is not properly seasoned, i.e. 25% moisture content or more, will over time cause the promet to disintegrate and require replacement.

Circulating fan (ECO Trend Insert only)

In all clean air zones, the Metro ECO Trend Insert must be fitted with Metro's ECO Insert fan, This is a single speed, permanently wired and thermostatically controlled device which runs continuously once the firebox reaches operating temperature. This fan is designed to run continually for many years without service, but should be checked monthly to ensure it is operating. If you are in any doubt regarding the fans operation, refer to your Metro retailer or a registered electrician immediately.

Flue systems

Should be checked annually, particularly the bottom end of the lower flue section at its rear lock formed joint. If deterioration is noticed contact your Metro retailer or installer.

The flue pipe should also be swept a minimum of once a year, or as required during the winter season. If smoke enters the room when you open the Metro's door this usually indicates the flue pipe is becoming restricted and needs cleaning. The frequency of flue pipe cleans depends on many factors, with the main variables being:

- The seasoning of the wood. If not properly seasoned you will require frequent flue pipe cleans.
- The density of the wood. Softwoods generally result in more deposits building up in the flue pipe.

To clean the flue pipe of your Metro, proceed as follows:-

- Open the Metro's door fully, reach inside with the palm of your hand face-up and extended, lift the top baffle approximately 20mm, then lift it forward out through the door opening, placing it on a sheet of newspaper you have placed on the front of the floor protector.
- Close the door and slide the air control to the left.
- Once on the roof, remove the cowl from the top of flue system and sweep the flue pipe using a 150mm-diameter flue pipe brush as detailed in the instructions provided with the fluebrush.
- Once the flue pipe is clear, clean and refit the cowl. Remove the excess soot which has fallen into the firebox, leaving a layer of ash 10mm deep on the base of the firebox, then refit the top baffle.

Note: The baffle must be fitted so its rear is touching the back of the firebox; if uncertain refer to page 4 in the installation section at the front of this manual, which shows illustrations of the baffle location.

Troubleshooting your Metro wood fire

If your Metro is installed correctly, your fuel is dry and you operate your fire correctly, you will find it to be a pleasure to use. Metro's many years of experience within the wood heating industry has shown that dissatisfaction is mainly due to:

- unseasoned fuel
- faulty installation
- operational error
- or a combination of the above 3 points.

Correct operation

Modern day wood fires need to be operated hard and fast, more so than low and lazy to ensure the firebox and flue pipe runs hot and efficiently. If the fire and flue pipe is up to temperature it will perform extremely well, the smoke will draw up the flue pipe with ease, and the fire will produce good amounts of heat.

If the fire is operated on low a lot of the time, the door glass will run black, the flue pipe will tend to block up more frequently and the fire will end up smoking into the room when reloading. It's better to have a small fire running hard and fast, rather than a big fire running low and lazy.

The following may be of assistance if you are experiencing any problems with the operation of your Metro Fire.

Smoke enters the room when the Metro's door is ajar

(possible reasons and solutions)

Check flue pipe joins

If the flue pipe joins are not sealed correctly, the flue pipe will not draw as well as it should. The flue pipe join connecting into the flue spigot on top of the Metro is most critical, if this is not sealed correctly, smoke will enter the room when the door is ajar. To check this join is sealed correctly, run a match or lighter flame around the join. If the flame is sucked into the spigot then it is not sealed correctly. This check needs to be done when the fire is not going. Ensure you check the rear of the flue pipe/spigot join, as due to the seam in the flue pipe, this is the most common area for not being sealed correctly.

Ensure the fuel you are using is correctly seasoned

If you are burning unseasoned fuel (wet), the fire will cause nothing but problems. The Metro won't deliver much heat, it will be lazy, smoke will enter the room when the door is ajar, and the door glass will run black. Unseasoned fuel is the main contributor to excessive creosote deposits which can be corrosive to your appliance and flue system.

Flue pipe length is too short

Add more flue pipe as the longer the flue system, the better the draw of the flue pipe. Please note, if you did not purchase the Metro ECO Flue System, you will not have the ECO Cowl which increases draw. We highly recommend the Metro ECO Cowl is fitted as this will increase the draw. If you already have an ECO Cowl and smoke is still entering the room, please add another 600mm length of flue pipe.

Downdraft/Turbulence blockage

If you have checked all of the previous factors and the fire is still smoking into the room, it's possible there may be a down draft issue. Down draft is environmental and can be caused by many variables, and it is purely trial and error to ascertain the cause.

Air turbulence and/or negative air pressure influences around the flue termination can be caused by too close or overhanging trees or natural/artificial ridges etc. Address these where possible or look to extend the flue above the roofline.

Other options may be:

- 'H' Cowl, designed purely for downdraft issues, but if you have an ECO Cowl fitted as standard, you will also need to add another 600mm of flue pipe to compensate as the H Cowl is shorter in length
- Directional Cowl, designed for high wind areas.

Air control setting

Ensure the air control setting is on high before opening the door to reload, as this increases the draw up the flue pipe. Open the door slowly.

If your Metro did not smoke, but its starting too and is getting worse:

The flue pipe is in need of a clean. It is recommended that the flue pipe be cleaned every season, however if you are burning the fire on low a lot, or are using unseasoned fuel, flue pipe cleans will be required more frequently.

Other issues you may experience

I can smell smoke in the room after a low burn cycle

The smell is creosote that will be seeping through the flue pipe join or out of the flue spigot onto an external surface, thus creating the smell in your room. The cause will be either unseasoned fuel, fuel mass too large, incorrect operation on low burn cycles or a combination. Creosote is very corrosive and excessive buildups will result in the flue pipe and potentially the flue spigot and upper burn chamber failing. The formation of excessive creosote is not an appliance issue, it is a fuel and operational issue. Failure of flue pipe or firebox due to creosote build up is not covered under warranty as excessive creosote build up is only possible from either unseasoned fuel or incorrect operation.

The Metro won't turn down as much as it did

The door itself may need readjusting, the hinge and latch is slotted and allows for movement. Loosening the hinge and moving it back a few mm will make the door seal tighter and stop air leaking into the fire. The door and glass seals may be in need of replacing, which is generally required every 3-4 years.

Familiarise yourself with the instructions on page 11 before proceeding with this maintenance.

Warranty details for your Metro wood fire

Metro wood fires are manufactured in New Zealand, using the highest quality of materials, workmanship and the latest manufacturing techniques, which is why we offer a full 10 year firebox warranty and a 1 year parts warranty for your peace of mind.

Metro Warranty

(NZ Consumer laws apply to this warranty)

Pioneer Manufacturing Limited (Pioneer) warrants the steel firebox against defective materials and workmanship which would render it unfit for normal domestic use, from the date of purchase by the original consumer, for a period of 10 years.

Components including panel coating, door retainers, door seals, glass, trim, baffle & bricks are warranted for a period of 1 year from the date of original purchase for normal domestic use against defective materials and workmanship.

All associated accessories including, but not limited to, fans, flue systems, flue shields, wetbacks, tool sets, ash pots etc, are covered by a 1 year warranty against defective materials and workmanship.

It is recommended, but not a condition of this warranty, that a full service/inspection of the Metro fire be carried out at the end of each winter season.

Warranty Conditions

- The Metro fire must be installed, operated and maintained strictly in accordance with the building code and this installation and operation manual
- The Metro fire must be installed and used in a domestic application
- This warranty covers appliance like for like replacement or repair at the manufacturer's discretion but excludes freight, travel, installation, labour and/or any other associated costs
- Pioneer or their agents are not liable for any loss or expense direct or indirect arising from the failure of any part or operation of the appliance
- Operation of this appliance in violation of the warnings in this operation and installation manual will void this warranty
- Your Metro fire must be regularly maintained and we recommended it is also serviced annually. Proof of servicing may be required. If a wood fire is not regularly maintained and serviced, the life span will be reduced. If your Metro wood fire has been neglected, by not being regularly maintained and serviced, warranty may be declined

CAUTION! Important Information

Note: The following 3 points require regular inspection/maintenance (every time the ash bed is cleaned out, generally 3-5 times a season) and if not maintained will void the firebox warranty. Please ensure you keep your proof of purchase/receipt on any parts you buy.

- It is critical the fire not be operated with over worn, faulty or missing door seals. Door seals will harden over time and become over-worn (3-4 year's) and will cause air to leak into the fire, causing the appliance to 'over fire'. Do not operate the fire with cracked, or broken door glass
- It is critical the fire not be operated with over worn, faulty or missing bricks, baffle plate or baffle extension (white board on or under the baffle plate)
- A claim under this warranty should be directed to the retailer who supplied the Metro fire. If this is not possible write directly to the manufacturer stating details of fault, model, serial number of your Metro, dated proof of purchase and name of retailer purchased from.

Warranty Exclusions

(This manufacturer's warranty does not cover)

- Service calls which are not related to any defect in the product (i.e. operational, installation or fuel issues). The cost of a service call will be charged if the problem is not found to be a product fault
- Defects caused by factors other than normal domestic use or use in accordance with the product's operation manual
- Defects caused through the product being operated in an 'over-fired' manner resulting in sections of the firebox operating excessively hot to the point that sections glow red. (Note – This will result in distortion of the firebox)
- Defects to the product caused by accident, neglect, misuse or act of God
- The cost of repairs carried out by non-authorized repairers or the cost of correcting such unauthorised repairs
- Required maintenance as set out in this manual.

Service under this manufacturer's warranty must be provided by a repairer authorised by Pioneer Manufacturing Ltd. Such service shall be provided during normal business hours.

IMPORTANT! Complete and retain these details at time of purchase:

Purchase Date

Serial Number

Model

Colour

Retailer



Parts guide for your Metro – Promet, baffles and wetback options

Your Metro wood fire must be regularly maintained and we recommended it is also serviced annually. If a wood fire is not regularly maintained and serviced, the life span will be reduced.

If your Metro wood fire has been neglected, by not being regularly maintained and serviced, with authorised Metro parts replaced as required, your warranty may be declined.







Listed below are the parts and product codes for your Metro wood fire. The promet/baffle should be regularly checked and must always be in place during the operation of your fire.

The baffle should be resting on four support lugs (two on each side of the firebox). It must be hard back against the rear of the firebox with the 'promet extension' (white board) or return front steel edge of the baffle facing forward.

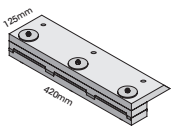
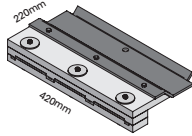
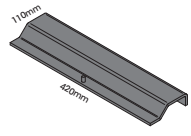
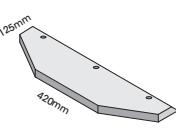
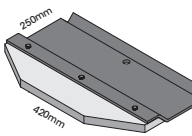
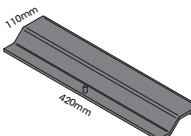
Hairline cracks in the promet extension are not uncommon and will have no adverse effect on the operation and performance of your Metro wood fire. These cracks are the result of intense heat coupled with expansion and contraction and is normal wear and tear.

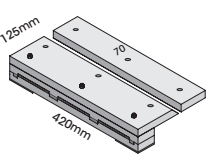
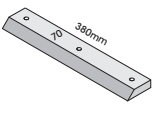
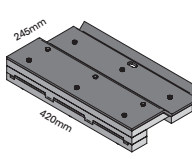
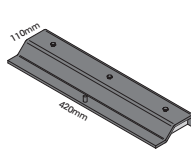
If the promet extension starts to break up and pieces fall into the firebox it must be replaced.

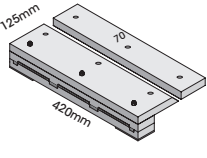
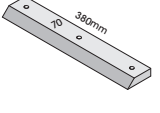
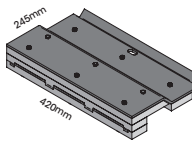
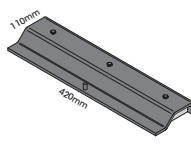
Note: Impact damage when loading wood and burning wood which is not properly seasoned, i.e. 25% moisture content or more, will cause the promet to disintegrate and require replacement. Always burn dry well seasoned wood and take care when loading wood into the firebox.

Model	Type of promet required / Type of steel baffle(s) required				Wetback options
• ECO Trend Insert	ECO Small Promet 500-1650 	ECO Insert Front 500-2250 	ECO/LTD Insert Rear 500-2300 	No wetback if this fire is installed in a clean air zone. The 3kW or 4kW Wetback can be fitted in a non-clean air zone. 3kW Wetback 450-0100 or 4kW Wetback 450-0150	
• LTD Trend Insert	LTD Small Promet 500-1700 	LTD Insert Front Baffle 500-2850 	ECO/LTD Insert Rear Baffle 500-2300 	3kW Wetback 450-0100 or 4kW Wetback 450-0150 	
• Smart Insert	Smart Front Promet 500-1675 	Smart Rear Promet 500-1800 	Smart Front Baffle 500-2350 	Smart Rear Baffle 500-2400 	Smart Booster 450-0350 
• LTD Smart Insert	Smart Front Promet 500-1675 	Smart Rear Promet 500-1800 	Smart Front Baffle 500-2350 	Smart Rear Baffle 500-2400 	Smart Booster 450-0350 

Metro - Visit us online today www.metrofires.co.nz

Metro wood fire specifications

Metro have a Specifications Brochure available which details relevant compliance data for every model. This brochure is updated annually and details the minimum clearances and specifications for all models, which is generally required when applying for a building consent. See your Metro retailer to obtain a copy, or visit www.metrofires.co.nz

metrofires.co.nz

Visit the Metro website: metrofires.co.nz to view Metro's 'video demos' showing the latest in wood fire technology energy saving options. You can view the entire Metro product range, find out where your nearest Metro retailer is located or simply check out the latest specifications, installation requirements and emission and efficiency data for the Metro of your choice.



Pioneer heating accessories

Pioneer/Metro Fires offer a range of heating accessories designed to compliment your Metro wood fire. See below for some of the products within our heating accessory range. The range of accessories includes floor

protectors, heat transfer systems, child guards, baffles, bricks and more. For further details ask your Metro retailer for a copy of the Pioneer/Metro Fires heating accessories brochure, or visit www.metrofires.co.nz



ECO Flue Systems

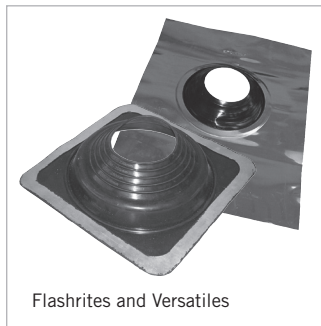

Flashrites and Versatiles



Wetbacks



High Temperature Paint



Child Guards



Heat Transfer Systems

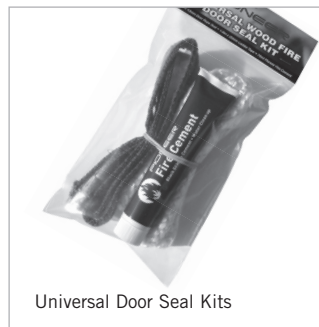

Universal Door Seal Kits



Fire Cement And Silicone



Corner and Wall Floor Protectors



Glass Tape



Door Seal Rope



Chubb Smoke Detectors

ECO Flue System Installation Manual



metrofires

ECO Flue Systems

Freestanding Flue Systems

ECO Flue System Installation Options	2
ECO Flue Kit / ECO Option Kit	3
ECO Flue Kit Installation	4-5
ECO Option Kit Installation.....	5-6

Insert Flue Systems

ECO Insert Kit Installation.....	7
ECO Flue System Minimum Heights	8

⚠ WARNING! Important Information

- Metro ECO Flue Systems must be installed to allow unrestricted air supply from either the ceiling cavity for an ECO Flue Kit, or above the roof line if the ECO Flue & ECO Option Kits are both installed. Please read these instructions and familiarise yourself with the installation options and various components of the ECO Flue Systems
- The ECO Flue Kit must be installed into a 'vented' flat ceiling cavity, or have an ECO Option Kit added to the flue system to provide an external air supply
- The ECO Flue Systems shall be installed in accordance with AS/NZS2918:2001 and the appropriate requirements of the relevant building codes
- Any modification to this flue system that has not been approved in writing by the testing authority is considered to be in breach of all approvals granted

⚠ CAUTION! Important Information

- Mixing of flue system components from different sources or modifying the dimensional specification or components may result in hazardous conditions. Where such action is considered, the manufacturer should be consulted.
- Prior to installing the assembled flue pipe into a masonry chimney cavity, take careful note to ensure there are no overhead power lines in close proximity.

ECO Flue Systems Installation Options

Detailed below are the more common installation methods for installing Metro ECO Flue Systems. To ensure a safe and efficient installation, this flue system must be installed as detailed below by either a registered installer, or someone competent in installing solid fuel appliances.

Single Storey Installations

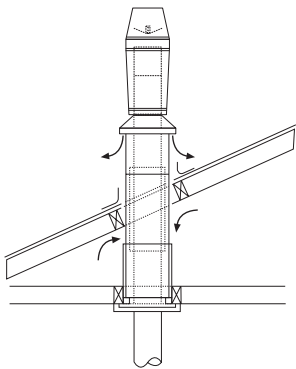

Flat Cavity Ceiling

ECO Flue Kit only required as air is drawn into the flue system direct from the ceiling cavity.

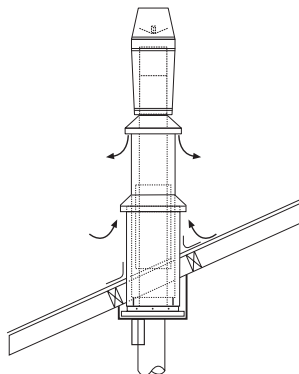

Sloping Ceiling

Both the ECO Flue Kit and ECO Option Kit are required to enable air to be drawn from outside the home.

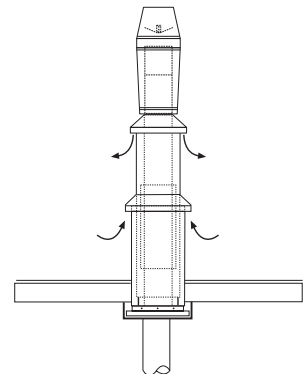

Flat Ceiling/Roof

Requires both ECO Flue Kit and ECO Option Kit as per sloping ceiling unless a vented ceiling cavity exists.

Two Storey Installations

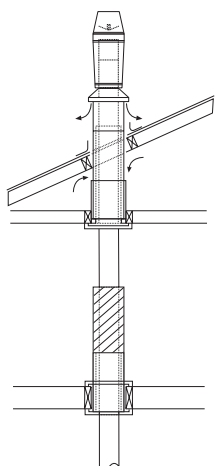

2nd Floor - Exposed Flue pipe

Requires an ECO Flue Kit only with additional lengths of flue pipe.

Additional components below are not supplied by Metrofires but are also required for this installation*

- A floor penetration kit
- 1x 1200mm long mesh/screen

*In accordance with AS/NZS2918:2001

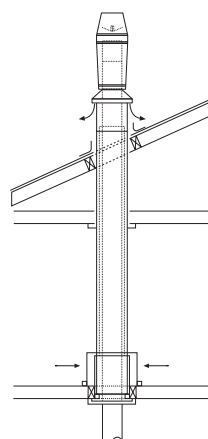

2nd Floor - Enclosed Flue pipe

Requires an ECO Flue Kit only with additional lengths of flue pipe.

Additional components below are not supplied by Metrofires but are also required for this installation*

- 200mm & 250mm inner/outer combination liners.
- 2nd floor vent cover and an additional ceiling plate with a 250mm diameter hole

*In accordance with AS/NZS2918:2001

ECO Flue Kit & ECO Option Kit Component Checklist

ECO Flue Kit

The ECO Flue Kit is designed for installation into a building that has a 'ceiling cavity' with unrestricted air supply as is the case with conventional homes. A vented ceiling cavity is required as the ECO Flue Kit draws its cooling air from within the ceiling cavity.

Metro offers both the ECO Flue Kit, which is designed to be installed on its own and the ECO Option Kit which is designed to be installed in conjunction with the ECO Flue Kit. The specific application for each of these two options is detailed below with installation instructions overleaf.

ECO Flue Kit components

- (A) 1 x Stainless steel weather butterfly
- (B) 1 x Stainless steel ECO Cowl top
- (C) 1 x 420mm x 240mm diameter stainless steel ECO Cowl housing
- (D) 1 x 480mm long stainless steel flue pipe extension with flashing cone
- (E) 1 x 1200mm x 150mm diameter stainless steel flue pipe
- (F) 1 x 1200mm x 250mm diameter galvanised outer casing with 750mm long slip section
- (G) 1 x 800mm x 200mm diameter galvanised inner casing
- (H) 1 x Galvanised mounting plate with brackets and 300mm long x 300mm diameter casing attached
- (I) 1 x insulation gasket
- (J) 1 x black clip-on ceiling plate
- (K) 2 x 1200mm lengths of 150mm diameter stainless steel flue pipe painted metallic black
- (+) 1 x Plastic bag of assembly bolts

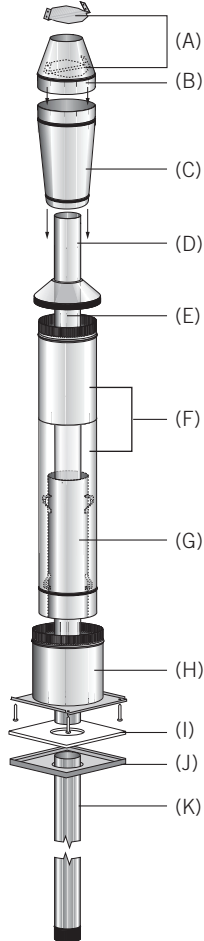

ECO Flue Kit assembled

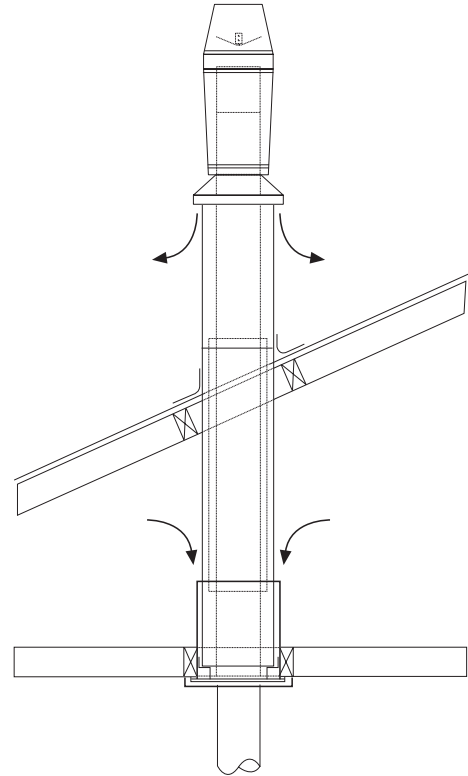

ECO Option Kit

The ECO Option Kit is designed to be 'added to' the ECO Flue Kit for installations that do not have a vented ceiling cavity and require the flue systems cooling air to be drawn in from above the roofline (outside the building).

ECO Option Kit components

- (L) External intake flashing cone
- (M) 1x 780mm x 300mm diameter outer liner extension
- (N) Drop box infill panel
- (O) Drop box edge covers
- (P) Ceiling plate mounted heat shield

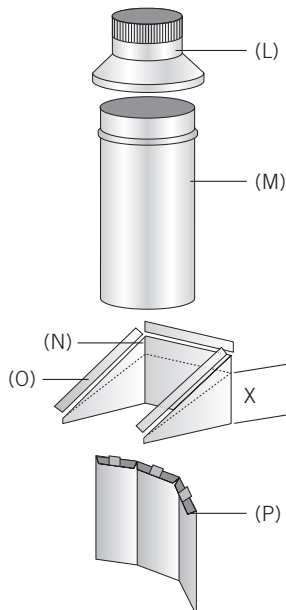

ECO Flue Kit & ECO Option Kit assembled

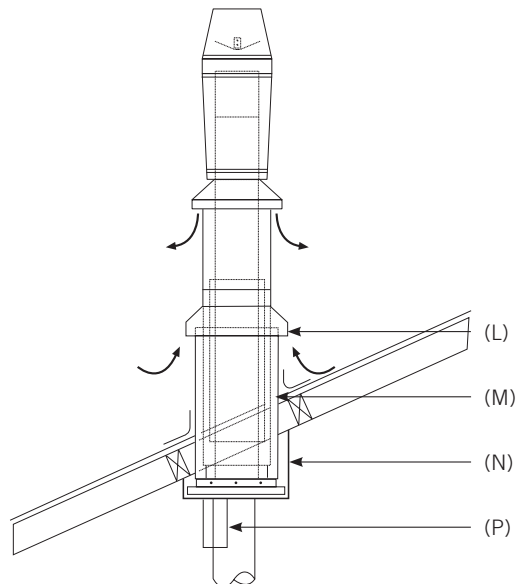

ECO Flue Kit Installation Instructions

ECO Flue Kit components

- (A) 1 x Stainless steel weather butterfly
- (B) 1 x Stainless steel ECO Cowl top
- (C) 1 x 420mm x 240mm diameter stainless steel ECO Cowl housing
- (D) 1 x 480mm long stainless steel flue pipe extension with flashing cone
- (E) 1 x 1200mm x 150mm diameter stainless steel flue pipe
- (F) 1 x 1200mm x 250mm diameter galvanised outer casing with 750mm long slip section
- (G) 1 x 800mm x 200mm diameter galvanised inner casing
- (H) 1 x Galvanised mounting plate with brackets and 300mm long x 300mm diameter casing attached
- (I) 1 x insulation gasket
- (J) 1 x black clip-on ceiling plate
- (K) 2 x 1200mm lengths of 150mm diameter stainless steel flue pipe painted metallic black
- (+) 1 x Plastic bag of assembly bolts

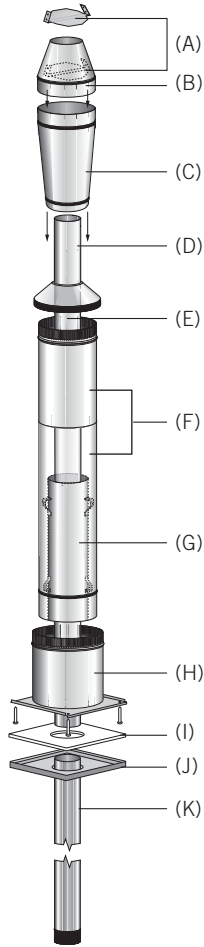

Having positioned the wood fire in the desired location, check to ensure the wood fire and floor protector have adequate clearances/projections, and that the flue system is clear of ceiling joists, trusses etc. (refer to the Wood Fire Installation and Operation Manual).

Note: ECO Flue Systems use stainless steel brackets enabling movement due to expansion, while centralising flue pipes and casings. These brackets may require resetting after transport, if they are too loose or tight during assembly;

1. At a point directly above the wood fires flue centre, cut a 300mm square hole through the ceiling and a 250mm diameter hole through the outer roof lining providing it is non combustible (iron, tiles etc) otherwise cut a 250mm square hole through the roof lining. 'Trim out' the top face of the ceiling using timber nog's creating a square aperture measuring 300mm internally.

Note: Certain flashing manufacturers detail specific size and shape of the aperture to be cut for their flashing, which must be adhered to.

2. Fit mounting plate (H) into the ceiling by sliding the 300mm diameter casing attached to the mounting plate up into the ceiling until the two upturned edges rest against the under side of the ceiling. Square the mounting plate to the wall and secure it in location with the four coach screws supplied, into the nogs just fitted. To further improve the rigidity of the installation, nail through the 300mm diameter casing at 4 points into the timber nogs.
3. Moving onto the roof with the 1200mm x 250mm diameter galvanised outer casing (F) with 750mm long slip section fitted, lower the slotted end of this casing (F) into the roof cavity until it locates inside the

brackets on the top face of the mounting plate. Return back into the room and using the 3 x 6mm bolts and washers supplied, securely bolt the base of the 250mm diameter outer casing into the rivet nuts pre-fitted into the mounting plate brackets.

Note: As there are three bolts, the outer casing can be rotated to ensure the lock-form seam is sheltered as much as possible from the prevailing weather direction.

4. Return back onto the roof and using a suitable flashing, weather proof the joint where the 250mm diameter outer casing penetrates the roof. Ensure the flashing used is compatible with the roofing material, and if fitting instructions are supplied with the flashing, these must be adhered to. Prior to fitting the flashing, by fitting stays securing the outer casing (F) to the roof material will further improve rigidity of the installation.
5. While on the roof fit the 800mm x 200mm diameter galvanised inner casing (G).

Note: This inner casing has a top and bottom, the bottom end has both internal and external brackets while the top end has external only. Fit the bottom end of this inner casing (G) down into the 250mm diameter outer casing (F) until the casings lower external brackets locate on the internal swadge of the outer casing.

⚠ WARNING! Important Information

- If there is timber or combustibles within 25mm of the outer casing (F) in a zone 'above the top end of the inner casing (G) and below the roof line' an additional 200mm inner casing must be fitted.

6. Moving back into the home, remove the plastic film from the ceiling plate (J) and place it black side down over the flue outlet of the wood fire. Using a high temperature black aerosol, spray around the hole in the centre of the white insulation gasket, and when dry lay this centrally on the ceiling plate.
7. Unwrap the two painted flue pipes (K) taking care not to mark the painted surface (use a metallic black Pioneer aerosol for touch ups) and proceed to assemble the three flue pipe sections as described below;
 - Smear an adequate amount of Pioneer fire cement inside the 'top/un-crimped' end of both painted flue pipes (K).
 - Taking the unpainted stainless steel flue pipe (E) insert its top 'un-crimped' end up through the mounting plate (H) and up into the casings until its bottom 'crimped' end is 1250mm above the top of the wood fire.
 - Take one of the two painted stainless steel flue pipes (K) and fit its lower 'crimped' end into the Metro wood fires flue outlet. Now lower the unpainted stainless steel flue (E) which is protruding down from the mounting plate so that it fully connects into the lower painted flue pipe (K). Ensure these two flue pipe sections are firmly connected and aligned, then secure with three stainless steel or monel rivets spaced equally around the joint.
 - Lift the two assembled flue pipe sections so the bottom of the lower section is 1250mm above the top of the wood fire, and repeat the above procedure to fit the remaining painted flue pipe (K).

ECO Flue Kit Installation Instructions - continued

- With all three flue pipe sections securely joined, lift this three section assembly out of the wood fires flue outlet, then move it slightly off centre and lower the flue pipe assembly 'on top' of the wood fires flue outlet. Smear an adequate amount of Pioneer fire cement inside the wood fires flue outlet (move the flue pipe assembly as required to ensure the entire flue outlet is coated in fire cement) then lower the flue pipe back into the wood fires flue outlet, with the vertical flue seam facing the rear.
- 8. Taking the ceiling plate (J) with insulation gasket (I) fitted which are laying on top of the wood fire, with the flue pipe passing through them. Carefully lift them up the flue pipe trying not to mark the painted flue, and clip the ceiling plate onto the mounting plate.
- 9. While still on the ground, assemble the ECO Cowl as follows;
 - Take the stainless steel weather butterfly (A) so the angled sections are facing up.
 - With both arms and angled sections of the stainless steel weather butterfly (A) facing up, fit it into the stainless steel ECO Cowl top (B), and secure in position through the holes provided with stainless steel rivets.

NOTE – Once fitted the weather butterfly will be slightly angled within the cowl housing.

- Fit the ECO Cowl top (B) into the ECO Cowl housing (C). Push both sections together until the swage ring on (B) rests completely on the open end of the cowl housing (C). Drill through the two pre-punched holes in the ECO Cowl housing and secure these two sections together with stainless steel rivets.
- The removable section of the ECO Cowl is now fully assembled.
10. Making your way back onto the roof, slide the 750mm long slip section of the outer casing (F) until the top of this slip section is 'level' **(+ or -10mm)** with the top of the 150mm stainless steel flue pipe, then secure this slip section of the outer casing with rivets.
 11. Fit the 480mm long flue pipe extension/flashing cone (D), with the flashing cone at the bottom, fit its short flue section inside the top of the already installed 150mm diameter flue pipe. Ensure the three brackets extended below the flashing cone fit 'outside' the outer casing slip section. Drill through the pre-punched hole in all three brackets into the outer casing slip and secure with rivets.
 12. Taking the removable section of the ECO Cowl, position it over the top of the stainless steel flue pipe extension, and slide it down fully. This removable section does not require riveting and enables easy removal for future flue cleaning.

Installation Instructions with the ECO Option Kit

ECO Option Kit

The ECO Option Kit is designed to be 'added to' the ECO Flue Kit for installations that do not have a vented ceiling cavity and require the flue systems cooling air to be drawn in from above the roofline (outside the building).

ECO Option Kit components

- (L) External intake flashing cone
- (M) 1x 780mm x 300mm diameter outer liner extension
- (N) Drop box infill panel
- (O) Drop box edge covers
- (P) Ceiling plate mounted heat shield

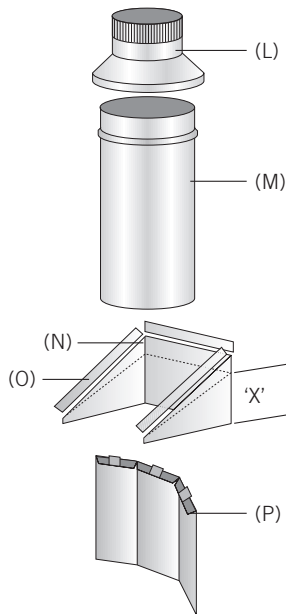

1. Slip the 300mm outer extension liner supplied with the ECO Option Kit over the 300mm outer liner 'stub' attached to the mounting plate (H) supplied with the ECO Flue Kit. Permanently secure these two components together by drilling four evenly spaced holes around the circumference and rivet with stainless steel rivets.
2. At a point directly above the wood fires flue centre, cut a 300mm square hole through the ceiling and a 300mm diameter hole through the outer roof lining providing it is non combustible (iron, tiles etc) otherwise cut a 300mm square hole through the roof lining. 'Trim out' the top face of the ceiling using timber nog's creating a square aperture measuring 300mm internally.

Note: Certain flashing manufacturers detail specific size and shape of the aperture to be cut for their flashing, which must be adhered to.

3. Fit mounting plate (H) into the ceiling by sliding the 300mm diameter casing attached to the mounting plate up into the ceiling until the two upturned edges rest against the under side of the ceiling. Square the mounting plate to the wall and secure it in location with the four coach screws supplied, into the nogs just fitted. To further improve the rigidity of the installation, nail through the 300mm diameter casing at 4 points into the timber nogs.

Dependent on whether you are installing into a flat roof/ ceiling or sloping ceiling situation as detailed on page 2, will determine if you require all the components of the ECO Option Kit. If installing into a flat ceiling/roof you will not require the drop box or drop box edge covers.

Note: The 300mm diameter outer liner extension (M) supplied with the ECO Option Kit is supplied at the maximum length it has been tested, and must not be extended.

- **If the ceiling is angled**, it is critical that the mounting plate is correctly positioned so the drop box in-fill panel can be fitted. Ensure the two 'upturned folds' on the mounting plate are aligned parallel to the roof joists, i.e pointing towards the apex.

You will only be able to use two of the securing holes provided in the mounting plate. To give additional support to the installation nail through the 300mm diameter outer liner into the timber framing, access is through the 200mm hole in the base of the mounting plate.

Installation Instructions with ECO Option Kit - continued

4. Moving onto the roof with the 1200mm x 250mm diameter galvanised outer casing (F) with 750mm long slip section fitted, lower the slotted end of this casing (F) into the roof cavity until it locates inside the brackets on the top face of the mounting plate. Return back into the room and using the 3 x 6mm bolts and washers supplied, securely bolt the base of the 250mm diameter outer casing into the rivet nuts pre-fitted into the mounting plate brackets. Return back onto the roof and using a suitable flashing, weather proof the joint where the 300mm diameter outer casing penetrates the roof. Ensure the flashing used is compatible with the roofing material, and if fitting instructions are supplied with the flashing, these must be adhered to.

Prior to fitting the flashing, by fitting brackets securing the outer casing (F) to the roof material will further improve rigidity of the installation.

Note: As there are three bolts, the outer casing can be rotated to ensure the lock-form seam is sheltered as much as possible from the prevailing weather direction.

5. Fit the external 'intake' flashing cone supplied with the Option Kit as illustrated, and secure it to the top of the 300mm diameter extension liner through the 4 x brackets which protrude below the base of the external 'intake' flashing cone.
6. While on the roof fit the 800mm x 200mm diameter galvanised inner casing (G).

Note: This inner casing has a top and bottom, the bottom end has both internal and external brackets while the top end has external only. Fit the bottom end of this inner casing (G) down into the 250mm diameter outer casing (F) until the casings lower external brackets locate on the internal swadge of the outer casing.

WARNING! Important Information

- If there is timber or combustibles within 25mm of the outer casing (F) in a zone 'above the top end of the inner casing (G) and below the roof line' an additional 200mm inner casing must be fitted.

7. Moving back into the home, remove the plastic film from the ceiling plate (J) and place it black side down over the flue outlet of the wood fire. Using a high temperature black aerosol, spray around the hole in the centre of the white insulation gasket, and when dry lay this centrally on the ceiling plate.
8. Unwrap the two painted flue pipes (K) taking care not to mark the painted surface (use a metallic black Pioneer aerosol for touch ups) and proceed to assemble the three flue pipe sections as described below;
- Smear an adequate amount of Pioneer fire cement inside the 'top/un-crimped' end of both painted flue pipes (K).
 - Taking the unpainted stainless steel flue pipe (E) insert its top 'un-crimped' end up through the mounting plate (H) and up into the casings until its bottom 'crimped' end is 1250mm above the top of the wood fire.
 - Take one of the two painted stainless steel flue pipes (K) and fit its lower 'crimped' end into the Metro wood fires flue outlet. Now lower the unpainted stainless steel flue (E) which is protruding down from

the mounting plate so that it fully connects into the lower painted flue pipe (K). Ensure these two flue pipe sections are firmly connected and aligned, then secure with three stainless steel or monel rivets spaced equally around the joint.

- Lift the two assembled flue pipe sections so the bottom of the lower section is 1250mm above the top of the wood fire, and repeat the above procedure to fit the remaining painted flue pipe (K).
 - With all three flue pipe sections securely joined, lift this three section assembly out of the wood fires flue outlet, then move it slightly off centre and lower the flue pipe assembly 'on top' of the wood fires flue outlet. Smear an adequate amount of Pioneer fire cement inside the wood fires flue outlet (move the flue pipe assembly as required to ensure the entire flue outlet is coated in fire cement) then lower the flue pipe back into the wood fires flue outlet, with the vertical flue seam facing the rear.
9. Taking the ceiling plate (J) with insulation gasket (I) fitted which are laying on top of the wood fire, with the flue pipe passing through them. Carefully lift them up the flue pipe trying not to mark the painted flue, and clip the ceiling plate onto the mounting plate.

10. While still on the ground, assemble the ECO Cowl as follows;

- Take the stainless steel weather butterfly (A) so the angled sections are facing up.
- With both arms and angled sections of the stainless steel weather butterfly (A) facing up, fit it into the stainless steel ECO Cowl top (B), and secure in position through the holes provided with stainless steel rivets.

NOTE – Once fitted the weather butterfly will be slightly angled within the cowl housing.

- Fit the ECO Cowl top (B) into the ECO Cowl housing (C). Push both sections together until the swage ring on (B) rests completely on the open end of the cowl housing (C). Drill through the two pre-punched holes in the ECO Cowl housing and secure these two sections together with stainless steel rivets.

The removable section of the ECO Cowl is now fully assembled.

11. Measure dimension 'X' as shown on page 3 and transfer this measurement to the drop box in-fill panel as shown.

- Cut the in-fill panel to the correct size and fit the 3 x edge covers.

Note: The side edge covers will require trimming on the ends to suit the angle of the ceiling.

- Secure the in-fill panel in position by fitting three rivets to each side through the holes provided.

12. Back in the room, lift the ceiling plate then attach the 'ceiling plate mounted heat shield' to the lower face of the ceiling plate so that it acts as a deflector shield between the flue pipe and the lower side of the ceiling (refer assembled diagram on page 3). This heat shield has three tabs on its top face enabling it to be 'clipped' into the 160mm diameter hole in the ceiling plate. Attach the ceiling plate by clipping it onto the mount plate and the installation is now complete.

ECO Insert Kit Installation Instructions & Component Checklist

Please read these instructions fully prior to installation of the ECO Insert Kit and familiarise yourself with all the various components illustrated right and listed below.

Note: Rivets, fire cement and chimney cap or flashing plate are not included as they are supplied by the installer.

ECO Insert Kit components

- (A) 1 x Stainless steel weather butterfly
- (B) 1 x Stainless steel ECO Cowl top
- (C) 1 x 420mm x 240mm diameter stainless steel ECO Cowl housing
- (D) 1 x 480mm long stainless steel flue pipe extension with flashing cone
- (E) 3 x 1200mm x 150mm diameter stainless steel flue pipe
- (F) 1 x 600mm x 250mm diameter galvanised outer casing

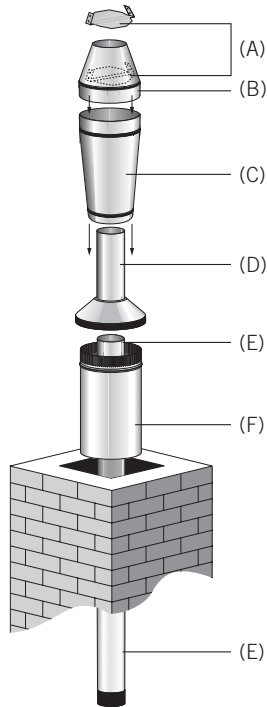

This flue kit has been manufactured and complies with AS/NZS2918:2001. To ensure a safe and efficient installation, this flue kit must be installed as detailed below by either a registered installer, or someone competent in installing solid fuel appliances.

1. Check the masonry chimney for structural soundness and make any repairs that are necessary.

Note: Most councils require the masonry chimney to be inspected prior to installation. The masonry chimney cavity must also be swept prior to installation.
2. Once the fireplace insert has been installed correctly as per the manufacturers instructions, look directly down the chimney to ensure the wood fire flue spigot is in line with the masonry chimney. (A torch will be required).
3. If you cannot see the flue spigot, a flue pipe offset will be required. If so, install the flue pipe offset so the top of it can be clearly seen from the top of the masonry chimney.
4. If an offset is required, an adjustable telescopic type is recommended. Measure the amount of offset required and adjust the telescopic offset to suit, after smearing an adequate amount of Pioneer fire cement onto the slip section of the offset to ensure a good seal, then rivet the offset in three locations around its circumference. (If the offset is used in its fully compressed form, it will be necessary to modify the end of the female slip section otherwise it will restrict the internal diameter) Apply a liberal amount of Pioneer fire cement into the flue outlet of the fireplace insert, and fit the lower crimped end of the offset into position inside the flue outlet, and bolt into position.

Note: In some installations where it is not possible to fit offsets or rigid flue pipe due to the shape of the masonry chimney cavity, 'Flexi flue' may be used.

5. Secure the flue pipes together and ensure the flue seams are in line. Flue pipe joints must be fully compressed with a considerable amount of fire cement to ensure a good seal, and then riveted together at three even points around the flue joint. Prior to installing the assembled flue pipe into the masonry chimney cavity, take careful note to ensure there are no overhead power lines in close proximity.
6. Lower the flue pipe into the masonry chimney, with the crimped end fitting into the fireplace insert flue outlet/offset, and securely attach with three rivets (offset/bend must be riveted to the flue pipe). For installations where extra lengths of flue pipe are required, or when the weather is poor, it will be easier to assemble the flue pipe lengths as they are lowered into the masonry chimney.
7. Secure the outer casing to the masonry chimney with suitable fasteners. A masonry chimney flashing plate will be required to weatherproof/seal the masonry chimney top. Note: The top of the outer casing must be 'level' (+ or -10mm) with the top of the 150mm stainless steel flue pipe.
8. Assemble the ECO Cowl as follows;
 - Take the stainless steel weather butterfly (A) so the angled sections are facing up.
 - With both arms and angled sections of the stainless steel weather butterfly (A) facing up, fit it into the stainless steel ECO Cowl top (B), and secure in position through the holes provided with stainless steel rivets.

NOTE – Once fitted the weather butterfly will be slightly angled within the cowl housing.
 - Fit the ECO Cowl top (B) into the ECO Cowl housing (C). Push both sections together until the swage ring on (B) rests completely on the open end of the cowl housing (C). Drill through the two pre-punched holes in the ECO Cowl housing and secure these two sections together with stainless steel rivets.

The removable section of the ECO Cowl is now fully assembled.
9. Making your way back onto the roof, fit the 480mm long flue pipe extension/flashing cone (D), with the flashing cone at the bottom. Fit the short flue section inside the top of the already installed 150mm diameter flue pipe. Ensure the three brackets extended below the flashing cone fit 'outside' the outer casing slip section. Drill through the pre-punched hole in all three brackets into the outer casing slip and secure with rivets.
10. Taking the 'removable section of the ECO Cowl' assembled in section (8) above, position it over the top of the stainless steel flue pipe extension, and slide it down fully. This removable section does not require riveting and therefore enables easy removal for future flue cleaning.

Minimum Heights for all Metro Flue Systems In compliance with AS/NZS2918:2001

The Metro ECO Flue Systems comply with AS/NZS2918:2001 and its 4.6 metre height requirement (4.6 metre minimum from the top of the floor protector to the top of the flue pipe). However as external structures and the proximity of other buildings will differ for every installation, some situations will require additional flue height to comply with the standard.

Refer to Diagrams 3 and 4 below. (All measurements in mm).

Note: AS/NZS2918:2001 Section 4, details flue system installation requirements in full.

Diagram 3

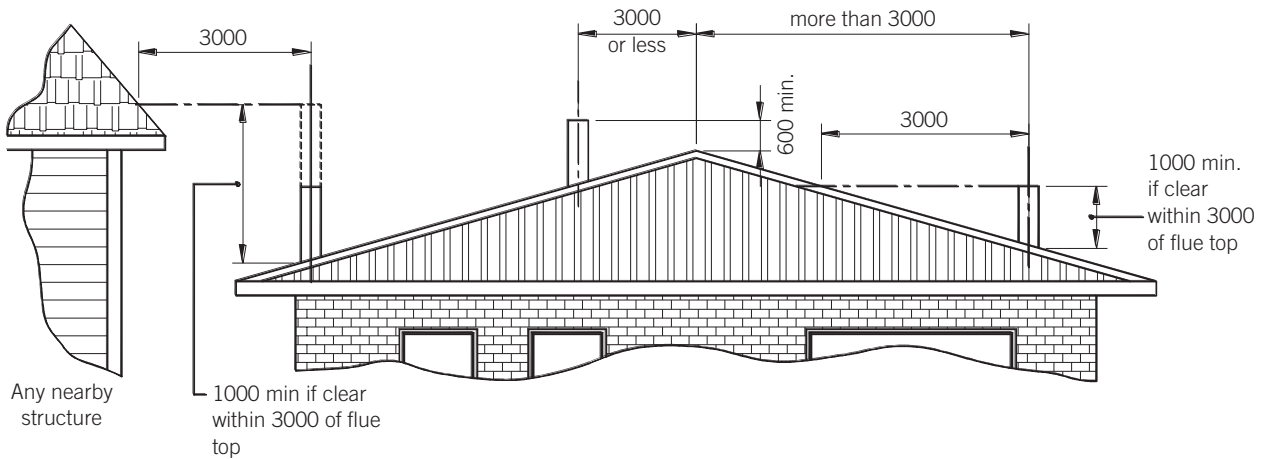
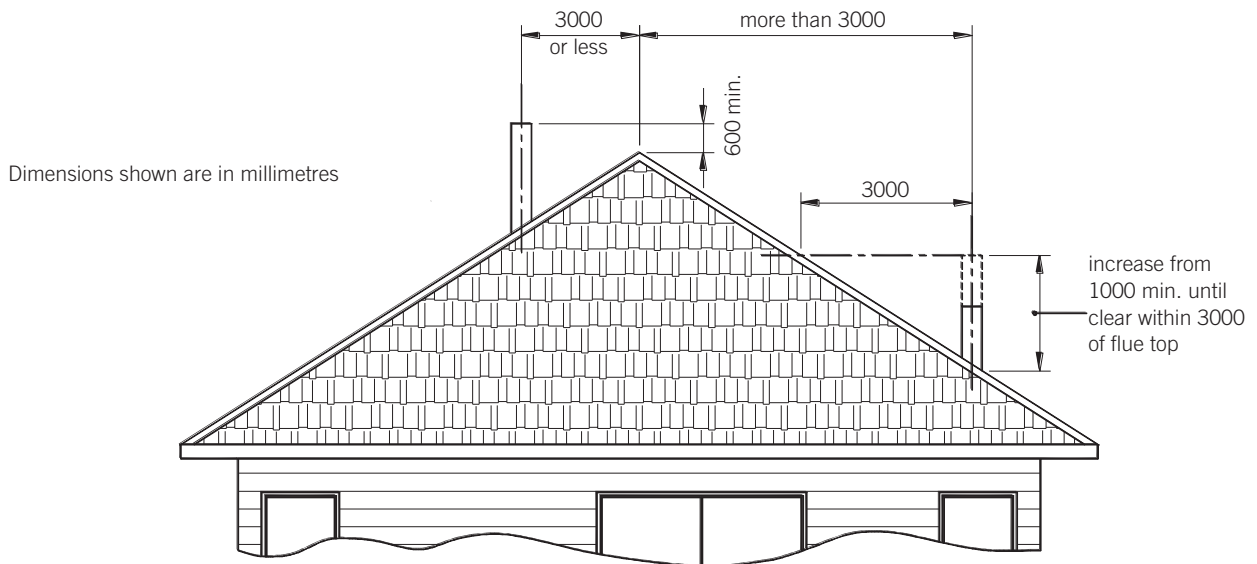

Diagram 4



APPLICATION FOR CODE COMPLIANCE CERTIFICATE (Form 6)

Section 92. Building Act 2004.

1. What is the Building Consent? *Complete this field*

Building consent number:	
Issued by: (name of building consent authority)	

2. Who owns the building? *Complete all fields, using N/A if a field is not applicable*

Owner name:		Title: e.g. Mr, Mrs, Ms, Dr	
Contact person:			
Owner mailing address:	-----		
Street address / registered office:	-----		
Owner email address:			
Owner contact numbers:	Ph:		Cell:
Are you using an Agent?	<input type="checkbox"/>	Yes	<input type="checkbox"/>
		No	<i>If Yes, please also complete the following</i>
Who is the first point of contact for further correspondence?	<input type="checkbox"/>	Agent	<input type="checkbox"/>
		Owner	
Agent name:			
Agent email:			
Agent contact numbers:	Ph:		Cell:
Agent mailing address:	-----		
Relationship to owner:			

3. When was the building work completed? *Complete this field*

All building work to be carried out under the building consent specified on this form was completed on:	dd /mm / yyyy

4. Who completed the building work? *Complete all fields on each line. You will need to complete one line for each building practitioner. Use a separate sheet if necessary.*

The licensed building practitioner(s) who carried out/supervised the restricted building work is/are:			
Name:	Licensing class:	LBP or registration number:	Work carried out / supervised:

Name:	Licensing class:	LBP or registration number:	Work carried out / supervised:
Tradespeople who carried out building work other than restricted building work are as follows:			
Name:	Address:	Contact number:	Registration number:
The following specified systems are contained on the compliance schedule for the building and, in the opinion of the personnel who installed them, are capable of performing to the performance standards set out in the building consent:			

5. Declaration

I understand that this application may *only* be made with the owner's approval. *Please tick to indicate your agreement.*

I request that you issue a code compliance certificate for this work under section 95 of the Building Act 2004. The code compliance certificate should be sent to:

Owner
 Agent
 Owner address as per Section 2
 Agent address as per Section 2

Name:

Signature:

Date:

You can add a digital signature to this document, either using Adobe or your existing digital signature.

Once you have filled out the form, including signatures, please save the application to your computer. You can then submit the application with supporting documentation to your local Council.

If you are unsure about what information to include in your application, a guidance document is available ([click here](#)).

6. Have you attached all required documents?

You are required to provide all the necessary documents to support your application. This includes (but is not limited to) the following sections:

- *Memorandum of Licensed Building Practitioners – Record of Work (for each type of building work completed)*
- *Certificates relating to energy work*
- *Evidence that specified systems are capable of performing to the performance standards set out in the building consent (if changed from the building consent)*
- *Other documents from personnel who carried out the work.*

Refer to your building consent approval letter for a full list of documents required to support your Code Compliance Certificate application.