

APPLICATION FOR BUILDING PERMIT

\$129. Wanganui City Council

Date: 02/12/80

THE CITY ENGINEER,

DEAR SIR,

I hereby apply for a Building Permit to erect/~~demolish~~ ADDITION TO DWELLING (CARPORT)

according to locality plan and detailed plans, elevation, cross sections and specifications of building deposited herewith, in duplicate at:

Street: 36 BROADHEAD AVE Val. No.: 13110/332
 Lot: 3 D.P. 22746 Section: _____ Block: _____

Owner—Name: M. CAPENDHURST
 Address: 36 BROADHEAD AVE
 Builder—Name: OWNER
 Address: _____

NATURE OF PERMIT (Tick box)

New building including separate buildings added to existing complex Repairs, alterations or extensions to an existing building Conversion Demolition

DESCRIPTION OF BUILDING OR STRUCTURE AND MAIN PURPOSE FOR WHICH IT WILL BE USED:

CARPORT

PREDOMINANT ACTIVITY OF OWNER

ESTIMATED VALUE:

Building \$ 470-00
 Plumbing & Drainage \$ _____
TOTAL \$ 470-00

Name of Plumber _____

If valued at more than \$20,000 state:
 Estimated commencement date: _____ Mth. 19____
 Estimated completion date: _____ Mth. 19____
 Building registration No. _____

Total floor area (sq.m)
14.4 m²

Building Fee	\$ 11-00	Rec. 39681
Plumbing & Drainage Fee	\$	Rec. _____
Water Connection	\$	PWR _____
Drain Connection	\$	PWR _____
Stormwater Connection	\$	PWR _____
Crossing Fee <u>EXIST</u>	\$	PWR 32581
Footpath Damage Deposit	\$	Rec. _____
TOTAL CITY COUNCIL FEES	\$ 11-00	
Building Research Levy	\$	Rec. _____
TOTAL	\$ 11-00	

Signature: M. Capendhurst

INFORMATION REQUIRED BY DEPARTMENT OF STATISTICS

A. TYPE OF BUILDING OR STRUCTURE—

(a) Newly built, altered, repaired, extended, or demolished

Type Code
 [See back of form for instructions]

04

(b) Converted—

from Type Code to Type Code

B. DWELLING UNITS GAINED OR LOST—

Gained Number Lost Number

C. IS BUILDING TO BE RENTED OR LEASED? (Tick appropriate box)

Yes No

ERECTED ON LAND OWNED BY CROWN?

Yes No

D. SCOPE OF PERMIT—(Tick box)

Complete building including foundations

foundations only

Building only, foundations covered by previous permit

13110/332

36 BROADHEAD AVE.

LOT 3 D.P. 22746

M. & J. CAPENERHURST

GENERAL REMARKS

BUILDING INSPECTOR:

HEALTH INSPECTOR:

DRAINAGE ENGINEER:

WATER ENGINEER:

DESIGNING ENGINEER:

TOWN PLANNING: 813m² R2

$$D = \frac{L + 3H}{10} =$$

$$\frac{7.2 + 4.8}{10} = 12.0$$

Access maintained

$$= \frac{12 + 3(2.6)}{10}$$

$$= 12 + 7.8$$

$$= 19.8$$

$$= \underline{2.0m}$$

The contour should be 2.0 from the boundary - please provide NC to apply for a dispensation. ~~OK~~ 3/12

WANGANUI CITY COUNCIL

NEIGHBOUR'S CONSENT FOR THE ERECTION OF A BUILDING

Address.....
.....
.....

TO WHOM IT MAY CONCERN:

I/~~we~~..... J. L. HUMPHREY.....
(Full name or names)

being the Owner / ~~Trustee~~ / ~~Lessee~~ (Strike out those which
do not apply) of a property situated at... 34... BROADHEAD AVE
... WANGANUI.....

have NO OBJECTION to the erection on the adjoining property being
36 BROADHEAD AVE..... WANGANUI.....
(Address where the building is to be erected)

by the owner/owners thereof..... M. CAPENERHURST.....
(Name of person wishing to build)

of a..... CARPART..... sited in
(Description of building)

accordance with the attached plan and constructed to the
Wanganui City Council Bylaws.

Signed J. L. Humphrey.....
Date 2-12-80.....

Signed
Date

(NOTE: Plan must be attached to this consent before signing)

Note: purlins to be standard grade
 prius radiata with moisture content
 18% or lower.

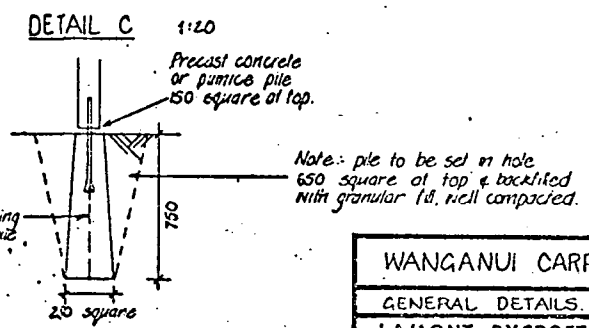
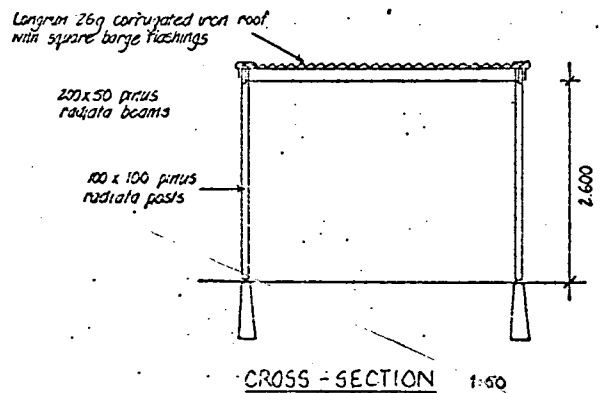
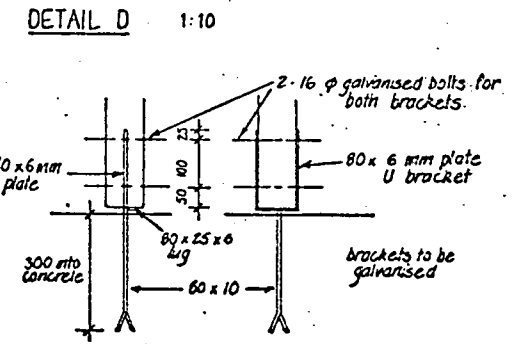
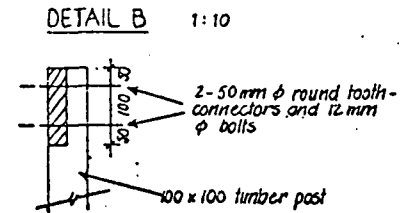
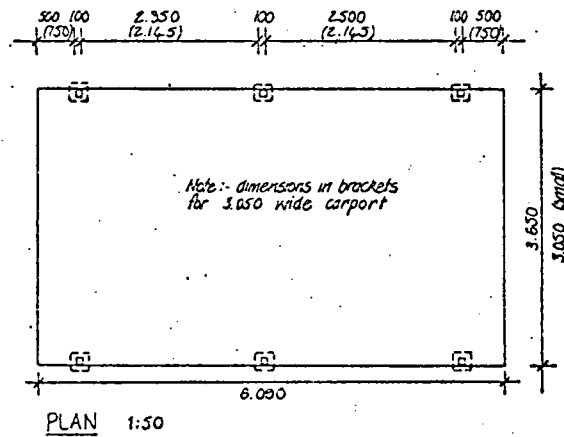
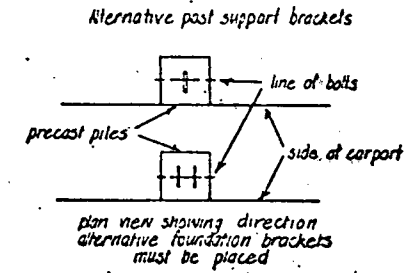
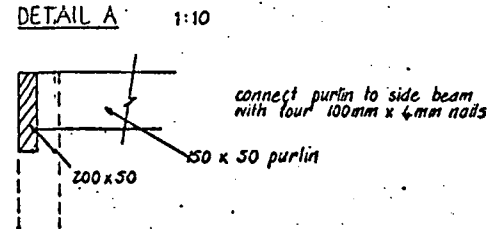
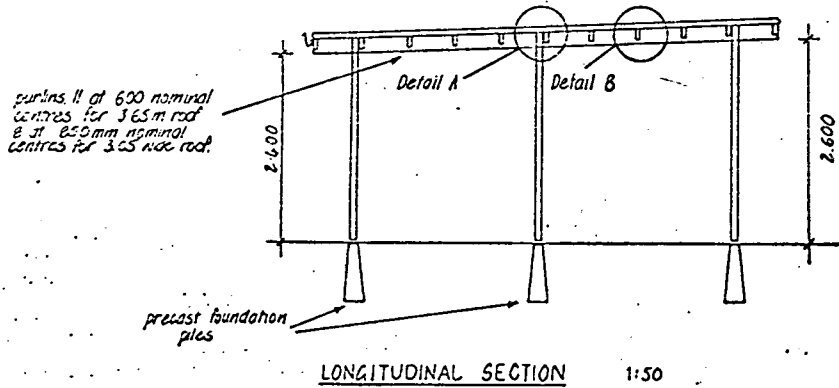

I. D. & B. J. KERR
 SKYLINE GARAGES, GARDEN SHEP
 GLASSHOUSES, CARPORTS,
 31 HEADS ROAD, WANGANUI,
 PH. 57-686. A/H 58-326.

WANGANUI CARPORTS.		Job No. 640
GENERAL DETAILS.		Sheet No.
LAMONT, BYCROFT & PARTNERS	as shown	1
ARCHITECTS ENGINEERS VALUERS	Design LBP	
TOWN PLANNERS LANDSCAPE ARCHITECTS	Draw LBP	
162 Wicksteed Street, Wanganui Phone 53-959	Date May 1980	

36 BROADHEAD AVE
CAPE TOWN

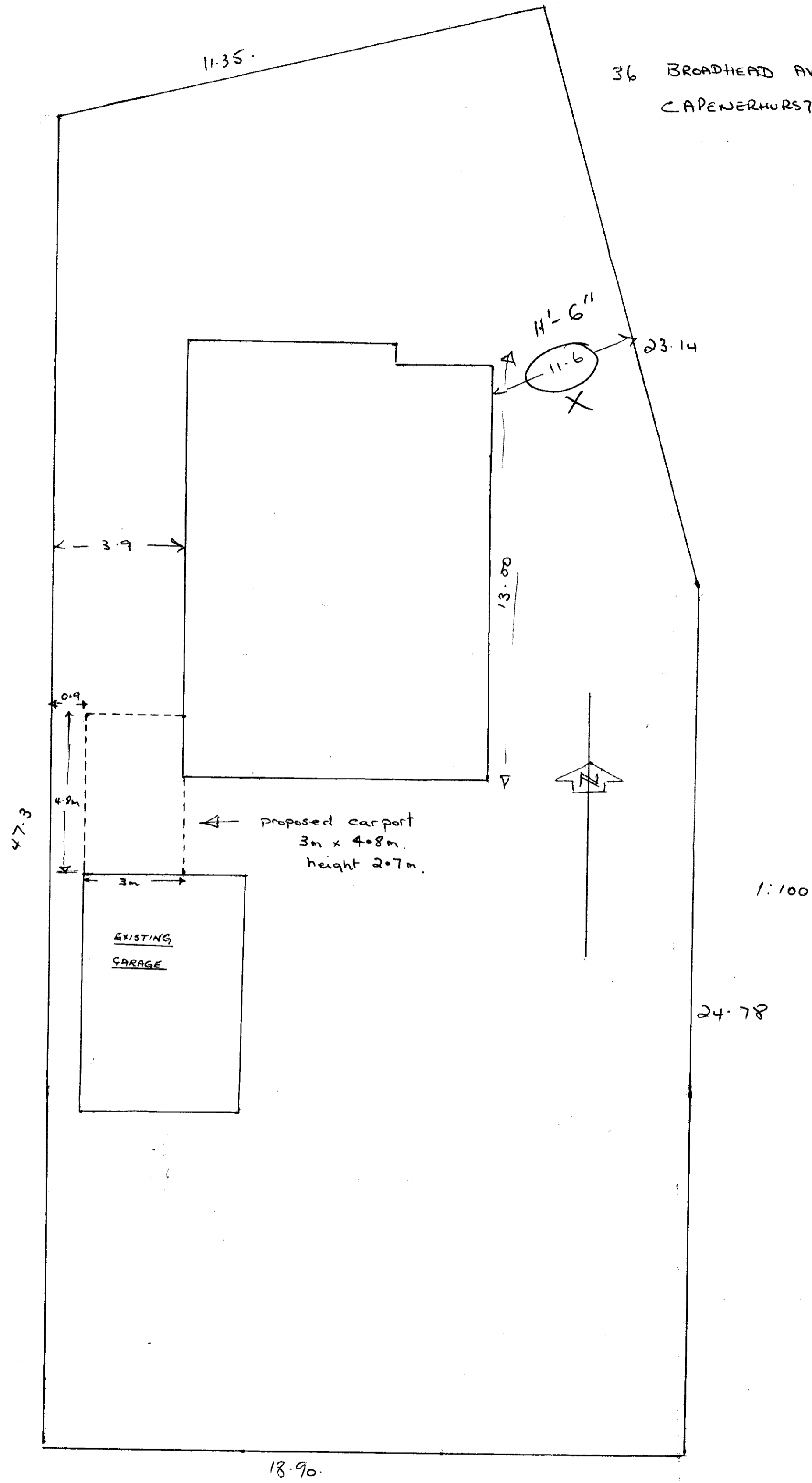

WANGANUI CITY COUNCIL

8781
BUILDING PERMIT

Owner: M. CAPENERHURST

Footway No.:

Builder: OWNER

Valuation No.: 13110/332

Type of Work: CARPORT

Permit No.: J034372

VALUE: \$470

INSPECTIONS

18.12.80

DATE

17.1.81

Completed

36 BROADHEAD

Street Lot

3

DPS

22746

Section

Block